

Galileo BOC(1,1) Prototype Receiver Development

Neil Gerein, *NovAtel Inc.*
Michael Olynik, *NovAtel Inc.*
Michael Clayton, *NovAtel Inc.*

BIOGRAPHY

Neil Gerein is a GPS Software Engineer with NovAtel Inc. has been involved with Galileo based receiver studies for the past three years. He has a B.Sc. and M.Sc. in Electrical Engineering from the University of Saskatchewan.

Michael Olynik is a GPS Software Engineer with NovAtel Inc. He has a B.Sc. and M.Sc. in Geomatics Engineering from the University of Calgary. He is currently doing development and testing of Galileo receivers.

Michael Clayton is a computer systems engineer with over twenty years of progressive responsibility developing and managing system solutions to meet user requirements. Michael graduated from the Royal Military College in 1978 with a Bachelor of Engineering (Electrical) and from Carleton University with a Masters of Engineering (Electrical) in 1984. Michael is a Registered Professional Engineer in Alberta (APEGGA). He was a Communications and Electronics Officer in the Canadian Forces from 1978 through 1990. From 1990 to 19991 Michael was the System Security Engineer on the Canadian Automated Air Traffic System. From 1991 through 1998, Michael was the Director of Software Engineering for a software services company. In 1998 Michael joined NovAtel and is currently Director – Aviation Programs.

ABSTRACT

In February 2004, the EU and the US reached an agreement on the baseline signal structure to be used in Galileo. Of particular interest to receiver manufacturers is the open service Binary Offset Carrier BOC(1,1) modulation format to be transmitted at the L1 frequency. In preparation for the transmission of the first Galileo signals from space, NovAtel initiated development of their first prototype Galileo receiver, capable of tracking BOC(1,1) signals.

NovAtel has successfully completed a contract with the Canadian Space Agency (CSA) to develop an FPGA based prototype of a Galileo BOC(1,1) receiver. The

receiver is based on NovAtel's new FPGA based precise positioning receiver, the Euro-L5. The receiver FPGA and software is configured to track the open service BOC(1,1) signal that will be transmitted on the Galileo L1 frequency. To reduce hardware design costs for this pre-production prototype development, the design was demonstrated at the L5/E5a frequency. No commercial Galileo hardware simulators are currently available to test the receiver. NovAtel modified an L5 signal transmitter, developed by NovAtel for Zeta Associates of Fairfax, Virginia, to output BOC(1,1) and BPSK(1) test signals.

An overview of the NovAtel Euro-L5 FPGA based precise positioning receiver will be presented. The CSA sponsored BOC(1,1) receiver/transmitter development effort will be discussed. The expected results for the pseudorange noise will be derived for the BPSK and BOC signals. Test results of the prototype BOC(1,1) receiver will be presented and compared with performance results from a BPSK(1) receiver and the expected results.

INTRODUCTION

Receiver manufacturers are anxiously waiting for the moment when they can track the first Galileo signals sent from space. It is anticipated that once Galileo is operational, the vast majority of all user receivers sold will be both GPS and Galileo capable. User benefits from receiving signals from both constellations will include improved accuracy, reliability, and availability. Currently, GPS users may find the signal path to the satellite constellation significantly reduced by buildings, trees, bridges or other obstructions. With twice as many satellites visible in the sky, the probability will be much lower that signal blockage will interfere with the navigation solution. Applications that are currently marginal, or impossible, will become viable and cost effective for users. In the meantime, much work needs to be done to produce Galileo capable receivers. Multiple signal types, multiple frequencies, and the new binary offset carrier (BOC) modulation scheme make the receiver design challenging. Initiating prototype receiver design effort now, in advance of a

finalized signal specification, will reduce the design risk in years to come.

In December 2003, NovAtel began work on a contract sponsored by the Canadian Space Agency (CSA) under the Space Technology Development Program (STDP), for the development of a Galileo prototype receiver (Gerein et al., 2004). Included in the contract, along with the development of the pre-production Galileo prototype receiver, was the modification of a GPS L5 transmitter to output a Galileo signal. The focus of the work was to track a single Galileo signal, specifically the open service BOC signal. The contract was successfully completed in July 2004.

The familiar GPS C/A code is a binary phase shift keying (BPSK) signal with a chipping rate of 1.023 MHz. The notation BPSK(f_c) is used, where f_c represents a factor of 1.023 MHz. The Galileo Open Service signal on L1 will be a BOC signal. For BOC signals, the spreading code is mixed with a square wave at a given subcarrier frequency. The notation BOC(f_s, f_c) is used, where f_s represents the square wave subcarrier frequency in units of 1.023 MHz, and f_c represents the chipping rate in units of 1.023 MHz. The generation of a BOC(1,1) signal is shown in Figure 1, where the top line is a 1.023 MHz square wave, the middle line is a 1.023 MHz spreading code, and the bottom line is the resulting BOC(1,1) modulation signal.

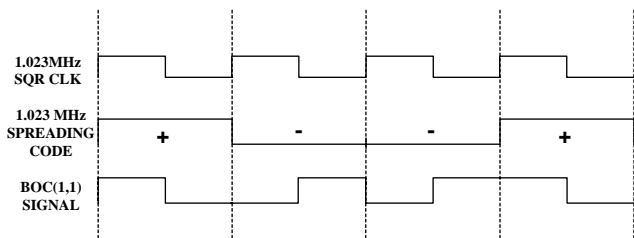

Figure 1 BOC(1,1) Signal Generation

The normalized ideal autocorrelation function for a BPSK(1) signal is shown in Figure 2. The autocorrelation function for a BOC(1,1) signal is shown in solid blue in Figure 3. Compared to the BPSK(1) autocorrelation function, the square wave subcarrier modulation used with BOC(1,1) causes the autocorrelation function to have a sharper main peak, and two smaller negative side peaks. The sharper main peak will result in improved code tracking performance for the BOC(1,1) signal, as well as improved multipath performance. The dotted red line in Figure 3 is the envelope of a BPSK(1) signal. Note that the ratio of the slope of the BOC(1,1) correlation peak to the BPSK(1) peak is 3:1.

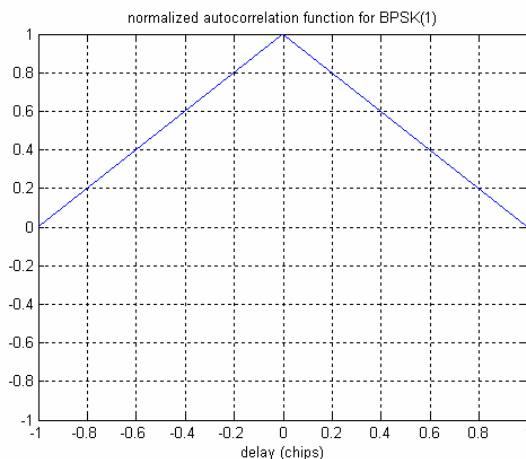

Figure 2 Correlation Function for BPSK(1)

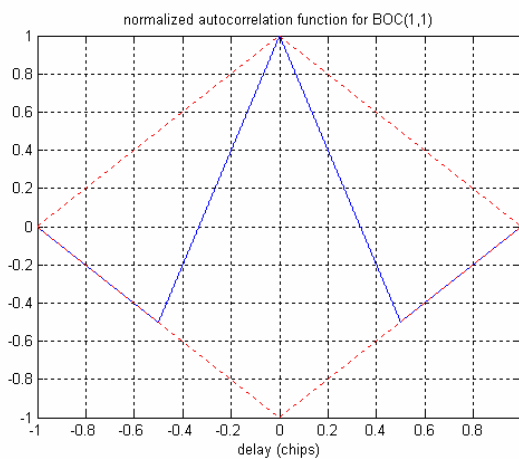

Figure 3 Correlation Function for BOC(1,1)

TRANSMITTER

NovAtel originally developed the prototype L5 Transmitter shown in Figure 4 for Zeta Associates of Fairfax, Virginia. The transmitter is packaged in a 1U high, 19 inch enclosure and includes: a NovAtel OEM4 receiver engine for the main processor; an FPGA to generate the spreading codes to transmit; and an L5 RF deck to up-convert the signal to the L5 transmit frequency of 1176.45 MHz. The L5 Transmitter was designed to transmit GPS L5, and therefore modulates data and pilot spreading codes in phase quadrature. Figure 5 is a screen capture from a spectrum analyser, with the transmitter in L5 GPS mode. The spectrum analyser was set for a centre frequency of 1176.45 MHz, 24 MHz span, and 10 kHz resolution bandwidth.

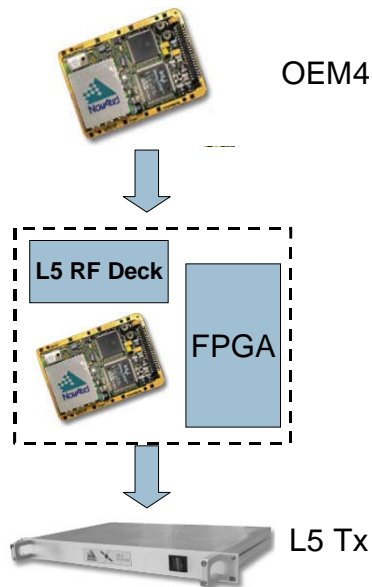

Figure 4 L5 Transmitter

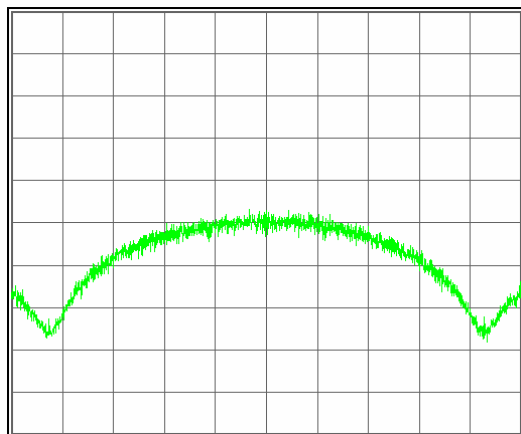

Figure 5 Transmitter Output - GPS L5

The software-defined nature of the transmitter allows for new spreading codes to be generated with relative ease. For this contract, the transmitter was reprogrammed such that the user can select either a BPSK(1) spreading code, or the same spreading code with a BOC(1,1) modulation. To minimize hardware re-design, the data and pilot codes are transmitted in phase quadrature, instead of the Coherent Adaptive Subcarrier Modulation (CASM) scheme that is currently being proposed for Galileo. The spreading code length is 4092 chips (4 ms), with forward error correction (FEC) encoded navigation data on the in-phase channel (250 symbols/second), and a length 25 secondary tiered code (100 ms) on the dataless quadrature channel.

Figure 6 is a screen capture from a spectrum analyser, with the transmitter in BPSK(1) mode (24 MHz span, 10 kHz resolution bandwidth). Figure 7 is the spectrum

analyser screen capture with the transmitter in BOC(1,1) mode. Figure 7 illustrates how the square wave subcarrier modulation used in BOC(1,1) shifts the main lobe of the frequency spectrum to higher and lower frequencies.

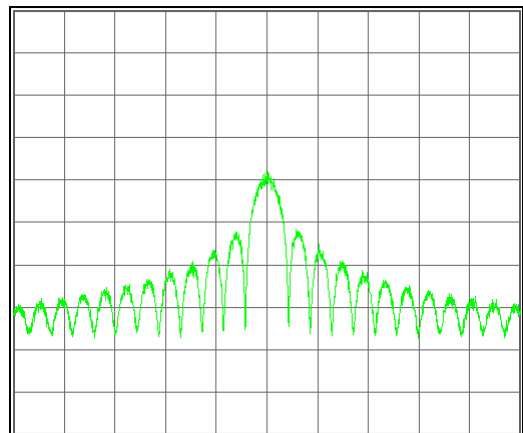

Figure 6 Transmitter Output - BPSK(1)

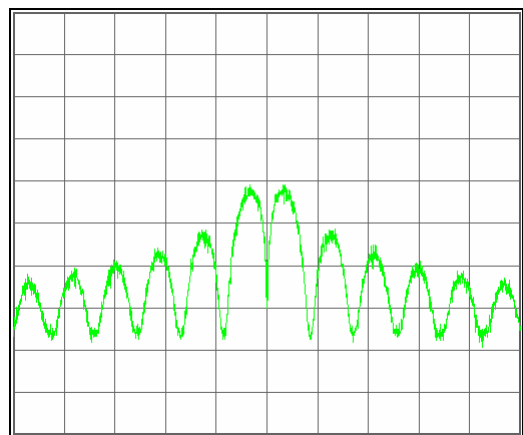

Figure 7 Transmitter Output - BOC(1,1)

SOFTWARE DEFINED RECEIVER

Software defined receivers are an ideal approach for prototype receiver development. The NovAtel Euro-L5 (see Figure 8) is a software defined receiver, developed for use in the WAAS Ground Uplink Station (GUS) receiver. The receiver is a Eurocard format receiver, based on the NovAtel OEM4-G2. The Euro-L5 is available in a standalone EuroPak-L5 enclosure (see Figure 9). The receiver is populated with an FPGA and can be configured to track the 4 channels of L5 WAAS or 4 channels of L5 GPS (compliant to RTCA/D0-261 NAVSTAR GPS L5 Signal Specification, December 14, 2000). The receiver also includes digital pulse blanking to mitigate in-band pulsed interference. Both the FPGA and baseband processor can be reprogrammed with new firmware via the serial port interface.



Figure 8 NovAtel Euro-L5 Receiver Card



Figure 9 NovAtel EuroPak-L5 Enclosure

The Euro-L5 was modified for this contract to track the Galileo BPSK(1) and BOC(1,1) signals output by the transmitter. The design cycle is: (a) implement new BPSK and BOC reference codes; (b) update baseband signal processing algorithms; (c) synthesis/compile design; (d) reprogram FPGA and baseband processor via serial port interface. The design cycle time is very quick compared to traditional ASIC design. For example, changes to the spreading code specification can be implemented and tested the same day.

The flexibility of the software defined receiver design update cycle has already proven itself useful. At the start of the contract, the Galileo signal specification for the open access service was defined as using a BOC(2,2) modulation. During the course of the development, Europe and the United States agreed to modify the proposed Open Service Galileo signal specification to use a BOC(1,1) modulation format. Both the transmitter and receiver designs were updated to reflect the changing signal specification.

TEST CONFIGURATION

The test configuration for the Galileo transmitter/receiver pair is shown in Figure 10. The Galileo transmitter, Galileo receiver, digitally controlled attenuator, and OEM4-G2 GPS receiver are all controlled from a host PC via serial port interfaces. The Galileo transmitter outputs a 'clean' signal, to which noise must be added. A wideband noise source outputs a constant noise power. The digitally controlled attenuator is used to adjust the noise power. The Galileo signals and attenuated noise are combined together at the L5 frequency using an RF combiner. The test configuration is calibrated to output the desired signal strength to the Galileo receiver. At any time, the expected C/No value input to the receiver may be adjusted by issuing a command from the host PC to the attenuator. The OEM4-G2 GPS receiver is used to provide an initial time solution to the Galileo receiver. The time is transferred via a serial data log and a 1PPS timing signal.

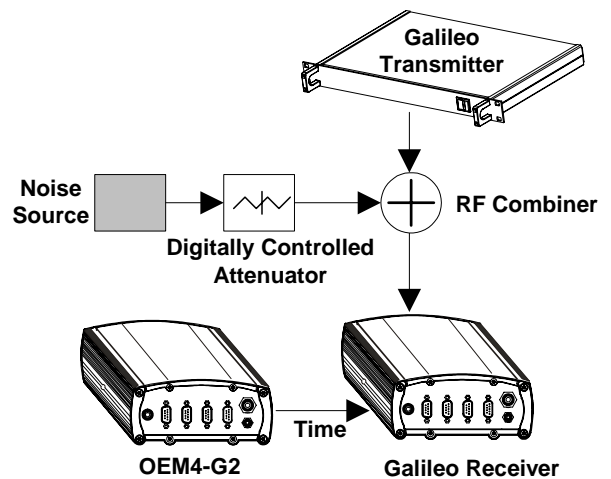

Figure 10 Galileo Receiver Test Configuration

With the Galileo receiver in the test configuration shown in Figure 10, and the transmitter and receiver both set to BOC(1,1) mode, an initial tracking test was initiated. For this initial test no checks were made in the receiver to ensure that the correct peak of the BOC(1,1) correlation function was being tracked. When the receiver initially acquires and tracks the BOC(1,1) signal, the receiver may be tracking one of the two side peaks located at ± 0.5 chips from the main peak, with a power 6 dB lower than the main peak power (see Figure 11). Tracking on the incorrect peak will cause a pseudorange error on the order of 146 meters.

The receiver was set to search for the transmitted BOC(1,1) code on multiple channels. Cases were

observed where one channel would acquire and track the main peak, while another channel would acquire and track the side peak. This is shown in Figure 12, where the channel tracking the main peak is at the expected power of 48 dB-Hz, while the channel tracking the side peak is at the expected side peak power 6 dB lower at 42 dB-Hz. The software defined Galileo receiver was then updated with a new firmware load to monitor and correct for side peak tracking. The design turn around time for implementing the changes on the FPGA was short enough that a number of different approaches to the side peak detection and correction algorithm were tested, and a final candidate solution was chosen. The new firmware load has eliminated the side peak tracking problem.

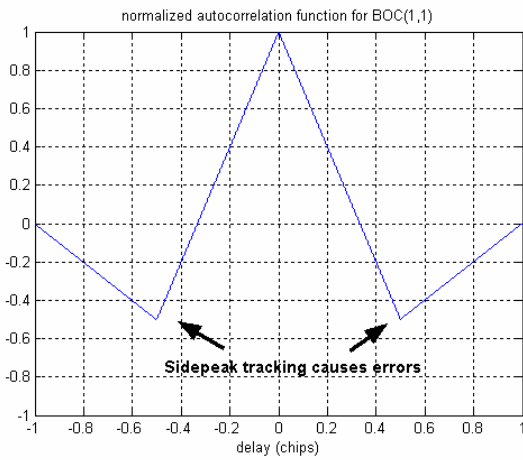

Figure 11 BOC(1,1) Correlation Function - Multiple Tracking Points

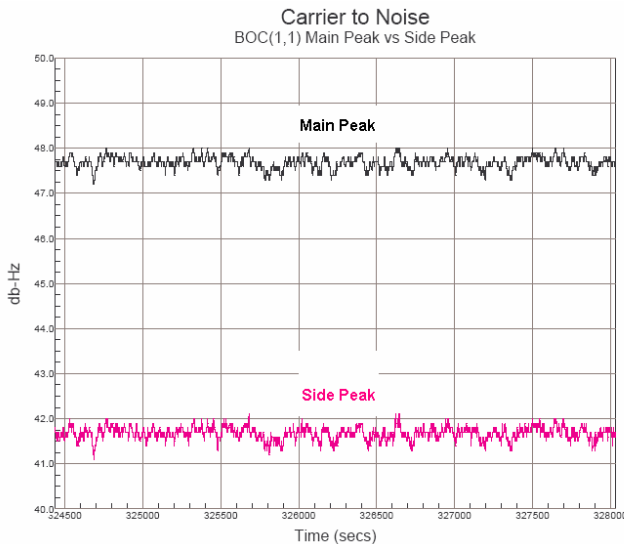

Figure 12 C/N0 Main Peak - 48 dB-Hz, C/N0 Side Peak 42 dB-Hz

Thermal noise tracking results for the BPSK(1) and BOC(1,1) are given later in this paper. The receiver

tracked the signal at each C/No for 30 minutes, with the C/No decreased by 1 dB each 30 minutes. The incorrect peak detection algorithm was used for testing the BOC signal, and worked properly in every case.

EXPECTED RESULTS

In this section we derive an approximate expression to predict the code tracking performance that can be expected by using a BOC(1,1) modulation scheme. The derivation of the approximate expression is based on the classic Narrow Correlator™ paper (Van Dierendonck et al., 1992).

The receiver implemented in the project used a dot-product discriminator for the code tracking Delay Lock Loop (DLL). The general description of a dot-product discriminator, $d\tau_k$, with a code error of τ_k chips is:

$$d\tau_k = I_{E-L,k}I_{P,k} + Q_{E-L,k}Q_{P,k} \quad (1)$$

where:

- E , P and L represent the correlator locations early, prompt and late respectively,
- I represents the in-phase correlators,
- Q represents the quadrature phase correlators,
- and k is the sample time that the correlator value is read.

The generic description of the I and Q sampled correlator outputs at time k , when summed over T seconds, is:

$$I_k = \sqrt{2C/NoTR_f}(\tau_k) \cos \phi_k + \eta_{Ik} \quad (2)$$

$$Q_k = \sqrt{2C/NoTR_f}(\tau_k) \sin \phi_k + \eta_{Qk} \quad (3)$$

where:

- C/No is the carrier to noise ratio in the predetection bandwidth of $1/T$ Hz,
- ϕ_k is the residual phase tracking error at time t_k ,
- τ_k is the code tracking error at time t_k ,
- R_f is the cross correlation function between the incoming filtered signal PRN code and the unfiltered reference code,
- and η_{Ik} and η_{Qk} are the in-phase and quadrature noise samples, respectively.

The expected value of the dot-product discriminator in equation 1, with a early-minus-late correlator spacing of d chips is:

$$E[d\tau_k] = \bar{I}_{E-L,k} \bar{I}_{P,k} + \bar{Q}_{E-L,k} \bar{Q}_{P,k} \quad (4)$$

$$= 2C/N_0 T [R_f(\tau_k - d/2) - R_f(\tau_k + d/2)] R_f(\tau_k)$$

For ease in calculating the expression, assume an infinite pre-correlation bandwidth (a valid assumption for BOC(1,1) and the 24 MHz bandwidth of the Euro-L5 receiver card). For BOC(1,1), the values for R_f are taken from the correlation function in Figure 11. Equation 4 can be simplified using the geometry of Figure 11 for code errors within the range $|\tau_k| \leq d/2$ to give:

$$E[d\tau_k] = 4 \cdot C/N_0 \cdot T \cdot 3 \cdot \tau_k \cdot (1 - 3 \cdot |\tau_k|) \quad (5)$$

The variances of the early-minus-late samples for BOC(1,1) are:

$$E[\eta_{IE-IL,k}^2] = E[\eta_{QE-QL,k}^2]$$

$$= E[\eta_{E,k}^2] - 2E[\eta_{E,k}\eta_{L,k}] + E[\eta_{L,k}^2] \quad (6)$$

$$= 2 - 2(1-3d) = 6d$$

where $(1-3d)$ is the correlation of the early noise sample to the late noise sample, based on the BOC(1,1) correlation function. After algebraic manipulation, the variance of the entire dot-product discriminator is given as:

$$\sigma_{d\tau}^2 \Big|_{\tau_k=0} = 12d(C/N_0 T + 1) \quad (7)$$

For the closed loop statistics, we proceed with the method of (Van Dierendonck et al., 1992), and define the first-order loop gain K_L as:

$$K_L = \frac{4B_L T \tau_k}{E[d\tau_k]} \Big|_{\tau_k=0} = \frac{B_L}{3C/N_0} \quad (8)$$

where B_L is the loop noise bandwidth. In steady state tracking, the closed loop noise variance is:

$$\sigma_\tau^2 \approx \frac{K_L^2}{8B_L T} \sigma_{d\tau}^2 \quad (9)$$

Substituting equations 7 and 8 into equation 9, and taking the square root gives the approximate expected 1-sigma code tracking performance of the BOC(1,1) modulation using a dot product discriminator:

$$\sigma_\tau = \sqrt{\frac{1}{3} \frac{B_L d}{2C/N_0} \left[1 + \frac{1}{C/N_0 T} \right]} \text{ (chips)} \quad (10)$$

For comparison, the expected 1-sigma code tracking performance of BPSK from (Van Dierendonck et al., 1992) is:

$$\sigma_\tau = \sqrt{\frac{B_L d}{2C/N_0} \left[1 + \frac{1}{C/N_0 T} \right]} \text{ (chips)} \quad (11)$$

The Galileo BOC(1,1) receiver, with a dot product discriminator as implemented in this contract, should offer a code tracking improvement of $1/\sqrt{3}$ over BPSK(1) (where 3 is the ratio of the slope of the BOC(1,1) main correlation peak to the BPSK(1) peak).

TEST RESULTS

The transmitter and receiver were set to track BPSK(1) and the C/No was varied over time. The receiver was set up to output range measurements, which were logged by the host computer. The test was run once for the data channel only, and again with the data/pilot channel (DLL and PLL tracking using pilot channel, data extraction from the data channel). Figure 13 shows the measured results from the receiver for BPSK Data and BPSK Data/Pilot, along with the expected value calculated using equation 11. As can be seen from Figure 13, the measured results agree with the expected results very well.

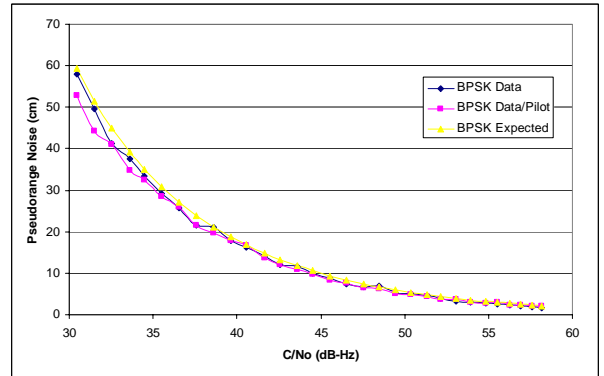

Figure 13 BPSK(1) code tracking performance – expected versus actual

A test similar to the one described above for BPSK(1) was completed for BOC(1,1). The expected performance was calculated using equation 10. The measured and expected results are shown in Figure 14. Again, the measured results from the receiver agree very well with theory, and validate the predictions of equation 10.

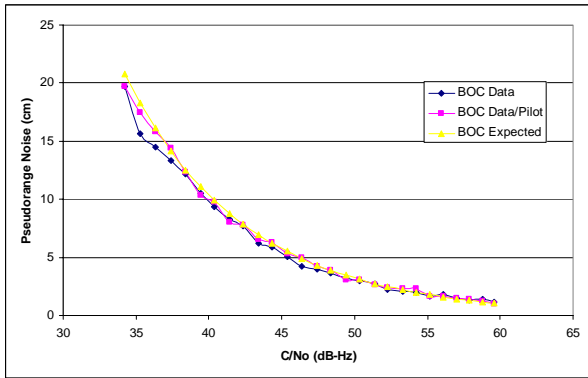

Figure 14 BOC(1,1) code tracking performance – expected versus actual

The measured results from Figure 13 and Figure 14 are plotted together in Figure 15 to emphasize the performance improvement of BOC(1,1) over BPSK(1). The improvement in pseudorange code tracking performance is approximately a factor of $1/\sqrt{3}$, as predicted earlier.

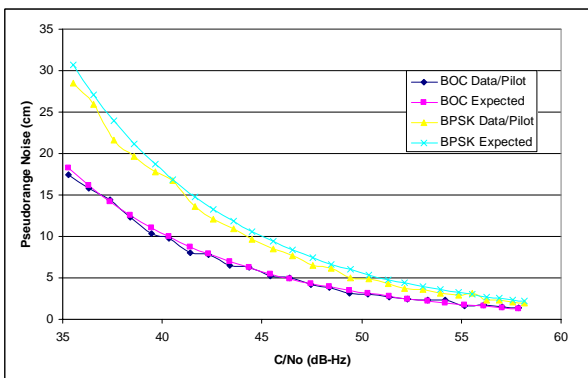

Figure 15 Measured code tracking performance – BPSK(1) versus BOC(1,1)

CONCLUDING REMARKS AND FUTURE WORK

The NovAtel Galileo prototype receiver, based on the NovAtel Euro-L5 hardware, successfully tracked the BOC(1,1) and BPSK(1) test signals. A monitoring algorithm was implemented to eliminate side peak tracking. Expected noise values were derived, and the results from testing were in agreement with theoretical predictions. The ratio of the noise level between BOC(1,1) of BPSK(1) is $1/\sqrt{3}:1$.

NovAtel soon expects to be awarded a follow-on contract with the Canadian Space Agency to continue with Galileo prototype receiver development. This project will include the development of a dual-frequency L1/E5a Galileo prototype receiver card, similar in function to the Euro-L5. The new dual-

frequency Galileo receiver card will be included with a NovAtel dual-frequency Euro-3M receiver card and clock/status card in a 19" rack mount receiver enclosure. The receiver enclosure design is based on the NovAtel WAAS-G2 second-generation ground reference receiver, and provides expansion capability to handle up to 10 additional receiver cards.



Figure 16 NovAtel WAAS Reference Receiver Enclosure

ACKNOWLEDGEMENTS

The authors wish to thank the Canadian Space Agency for financial and program support under CSA Contract #9F028-034100/006/MTD, and Zeta Associates for the use of the prototype L5 transmitter.

REFERENCES

- Gerein, N., M. Olynik, "Prototype Galileo Receiver Development", *Proceeding of the European Navigation Conference GNSS 2004*, Rotterdam, May 2004
- Van Dierendonck, A. J., P. Fenton, T. Ford, "Theory and Performance of Narrow Correlator Spacing in a GPS Receiver", *Navigation: Journal of the Institute of Navigation*, Vol. 39, No. 3, Fall 1992.