

OEM4 Family

USER MANUAL - VOLUME 1
Installation and Operation

OEM4 Family of Receivers Installation & Operation Manual

Publication Number: OM-20000046
Revision Level: 19
Revision Date: 2005/12/22

Proprietary Notice

Information in this document is subject to change without notice and does not represent a commitment on the part of NovAtel Inc. The software described in this document is furnished under a licence agreement or non-disclosure agreement. The software may be used or copied only in accordance with the terms of the agreement. It is against the law to copy the software on any medium except as specifically allowed in the license or non-disclosure agreement.

No part of this manual may be reproduced or transmitted in any form or by any means, electronic or mechanical, including photocopying and recording, for any purpose without the express written permission of a duly authorized representative of NovAtel Inc.

The information contained within this manual is believed to be true and correct at the time of publication.

NovAtel, GPSolution, ProPak, RT-20 and RT-2 are registered trademarks of NovAtel Inc.

FlexPak, PAC, GPSCard, and GPSAntenna are trademarks of NovAtel Inc.

All other brand names are trademarks of their respective holders.

Manufactured and protected under U.S. Patent:

Narrow Correlator

#5,101,416

#5,390,207

#5,414,729

#5,495,499

#5,809,064

PAC Correlator

#6,243,409 B1

Dual Frequency GPS

#5,736,961

Anti-Jamming Technology

#5,734,674

Position for Velocity Kalman Filter

#6,664,923 B1



© Copyright 2000-2005 NovAtel Inc. All rights reserved. Unpublished rights reserved under International copyright laws. Printed in Canada on recycled paper. Recyclable.

Table of Contents

Proprietary Notice	2
Software License	9
Warranty Policy	11
Customer Service	12
Notice	13
Foreword	16
1 Introduction	17
1.1 Overview of the OEM4 Family	17
1.1.1 Common Features.....	17
1.2 GPSCards.....	18
1.2.1 OEM4-G2L GPSCard.....	18
1.2.2 OEM4-G2 GPSCard.....	19
1.3 Enclosures	20
1.3.1 FlexPak.....	21
1.3.2 ProPak-G2plus	22
1.3.3 ProPak-LBplus.....	23
2 Receiver System Overview	25
2.1 GPSCard.....	26
2.1.1 Radio Frequency (RF) Section	26
2.1.2 Digital Electronics Section	26
2.2 Enclosure and Wiring Harness	26
2.3 GPS Antenna	26
2.3.1 Optional LNA Power Supply	26
2.4 Principal Power Supply	27
2.5 Data Communications Equipment	27
3 Installation and Set Up	28
3.1 Additional Equipment Required	28
3.1.1 Selecting a GPS Antenna.....	28
3.1.2 Choosing a Coaxial Cable	28
3.1.3 Power Supply Requirements.....	29
3.2 Installation Overview.....	30
3.2.1 Installing a GPSCard in a Wiring Harness and Enclosure.....	31
3.2.2 Mounting the GPS Antenna.....	34
3.2.3 Connecting the Antenna to the Receiver.....	34
3.2.4 Applying Power to the Receiver	35
3.2.5 Connecting Data Communications Equipment.....	35
3.3 Additional Features and Information	36
3.3.1 Strobes	36
3.3.2 USB (OEM4-G2/-G2L, FlexPak and ProPak-G2plus Only).....	38
3.3.3 Status Indicators.....	38

3.3.4 External Oscillator (OEM4-G2/-G2L and ProPak-G2plus Only)	39
3.3.5 External Antenna LNA Power (OEM4-G2 Only)	40
3.3.6 Mounting Bracket (ProPak-G2plus and ProPak-LBplus Only)	40
4 Operation	41
4.1 Communications with the Receiver	42
4.1.1 Serial Port Default Settings	42
4.1.2 Communicating Using a Remote Terminal	42
4.1.3 Communicating Using a Personal Computer	42
4.2 Getting Started	43
4.2.1 Starting the Receiver	43
4.2.2 Remote Terminal, PC and GPS Receiver	44
4.3 Transmitting and Receiving Corrections	45
4.4 Enabling SBAS Positioning	47
4.5 Enabling L-Band Positioning (ProPak-LBplus Only)	47
4.6 Pass-Through Logging	48
4.7 Transferring Time Between Receivers	50
4.7.1 Procedures	50
5 Message Formats	52
5.1 RTCA-Format Messages	52
5.1.1 RTCA1	52
5.1.2 RTCAEPHEM Type 7	53
5.1.3 RTCAOBS Type 7	53
5.1.4 RTCAREF Type 7	54
5.2 RTCM-Format Messages	54
5.2.1 RTCM1	55
5.2.2 RTCM3 Base Station Parameters (RTK)	56
5.2.3 RTCM9 Partial Satellite Set Differential Corrections	56
5.2.4 RTCM15 Ionospheric Corrections	57
5.2.5 RTCM16 Special Message	58
5.2.6 RTCM18 and RTCM19 Raw Measurements (RTK)	58
5.2.7 RTCM20 and RTCM21 Measurement Corrections (RTK)	59
5.2.8 RTCM22 RTCM Extended Base Station Parameters (RTK)	59
5.2.9 RTCM59 Type 59N-0 NovAtel Proprietary Message (RTK)	59
5.3 RTCM Version 3.0 (RTCMV3) Messaging	60
5.3.1 RTCM1001-RTCM1004 GPS RTK Observables	60
5.3.2 RTCM1005 & RTCM1006 RTK Base Antenna Reference Point (ARP)	61
5.4 CMR Format Messaging	61
5.4.1 Using RT-2 or RT-20 with CMR Format Messages	62
5.5 NMEA Format Data Logs	63
6 Positioning Modes of Operation	64
6.1 Single-Point	64
6.1.1 GPS System Errors	66
6.2 Satellite-Based Augmentation System (SBAS)	67
6.2.1 SBAS Receiver	69
6.2.2 SBAS Commands and Logs	70
6.3 Pseudorange Differential	70

6.3.1 Pseudorange Algorithms	70
6.3.2 Position Solutions	70
6.3.3 Dual Station Differential Positioning	71
6.4 L-Band Positioning	74
6.4.1 Coverage	74
6.4.2 L-Band Service Levels	76
6.4.3 L-Band Commands and Logs	78
6.5 Carrier-Phase Differential	79
6.5.1 Real-Time Kinematic (RTK)	81
7 PC Software and Firmware	89
7.1 GPSolution/Convert Installation	89
7.2 GPSolution	89
7.3 Convert	92
7.3.1 Rinex Format	93
7.3.2 Convert Command Line Switches	94
7.4 USB Drivers Installation	96
7.4.1 Windows XP Installation	96
7.4.2 Windows 2000 Installation	97
7.4.3 Windows Driver Signing	97
7.5 Firmware Upgrades & Updates	99
7.5.1 Upgrading Using the AUTH Command	100
7.5.2 Updating Using the WinLoad Utility	101
8 Built-In Status Tests	105
8.1 Overview	105
8.2 Receiver Status Word	105
8.3 Error Strobe Signal	106
8.4 RXSTATUSEVENT Log	106
8.5 Receiver Status Log	106
8.5.1 Overview	106
8.5.2 Error Word	107
8.5.3 Status Code Arrays	108
8.5.4 Receiver Status Code	108
8.5.5 Auxiliary Status Codes	108
8.5.6 Set and Clear Mask for all Status Code Arrays	109
8.6 Status LED	109
9 Troubleshooting	111
9.1 Examining the RXSTATUS Log	113
APPENDICES	
A Technical Specifications	116
B Electrostatic Discharge Control (ESD) Practices	151
C Replacement Parts	154
D Specifications Archive	156

Figures

1	OEM4-G2L GPSCard	18
2	OEM4-G2 GPSCard	19
3	FlexPak Enclosure	21
4	ProPak-G2plus Enclosure	22
5	ProPak-G2plus Rear Panel	22
6	ProPak-LBplus and Its Rear Panel	23
7	GPS Receiver System Functional Diagram	25
8	Typical Receiver Installation	31
9	OEM4-G2L Connector and Indicator Locations	33
10	OEM4-G2 Connector and Indicator Locations	34
11	Typical Operational Configuration	41
12	Pass-Through Log Data	49
13	1PPS Alignment	51
14	Single-Point Averaging (Typical Results)	65
15	Single-Point Averaging (Typical Results with WAAS)	66
16	The SBAS Concept	69
17	Typical Differential Configuration	72
18	CDGPS Frequency Beams	75
19	CDGPS Percentage Coverage Map	76
20	OmniSTAR Concept	78
21	Typical RT-2 Horizontal Convergence - Static Mode	84
22	Typical RT-2 Horizontal Convergence - Kinematic Mode	84
23	Typical RT-20 Convergence - Static Mode	86
24	Typical RT-20 Convergence - Kinematic Mode	86
25	Convert Screen Examples	92
26	Convert Command Line Arguments	95
27	Main Screen of WinLoad	102
28	WinLoad's Open Dialog	102
29	Open File in WinLoad	103
30	COM Port Setup	103
31	Searching for Card	103
32	Authorization Code Dialog	104
33	Update Process Complete	104
34	Location of Receiver Status Word	106
35	Reading the Bits in the Receiver Status Word	107
36	Location of Receiver Error Word	107
37	Reading the Bits in the Receiver Error Word	108
38	Status LED Flash Sequence Example	110
39	OEM4-G2L Board Dimensions	117
40	Top-view of 24-Pin Connector on the OEM4-G2L	120
41	OEM4-G2 Board Dimensions	121
42	Top-view of 40-Pin Connector on the OEM4-G2	125
43	FlexPak Power Cable	131
44	FlexPak 13-Pin Serial Cable	132
45	FlexPak 13-Pin Serial Cable	133

46	FlexPak USB Cable	134
47	ProPak-G2plus Power Cable	138
48	ProPak-G2plus Null Modem Cable	139
49	ProPak-G2plus Straight Through Serial Cable	140
50	ProPak-G2plus I/O Strobe Port Cable	141
51	USB Serial Cable	142
52	ProPak-LBplus Port Pin-Outs	145
53	ProPak-LBplus Power Cable	147
54	ProPak-LBplus 6-Pin Serial Cable	148
55	ProPak-LBplus 7-Pin Serial Cable	149
56	ProPak-LBplus 8-Pin Serial Cable	150
57	ProPak-G2 Power Cable	162
58	ProPak-G2 (DB-9 Version) Y-Type Null Modem Cable	163
59	ProPak-G2 (DB-9 Version) Straight Serial Cable	164
60	ProPak-G2 (DB-9 Version) I/O Strobe Port Cable	165
61	ProPak-G2 (LEMO Version) Null Modem Cable	166
62	ProPak-G2 (LEMO Version) Straight Serial Cable	167
63	OEM4 Board Dimensions	168
64	Top-view of 40-Pin Connector on the OEM4	172
65	Euro4 Board Dimensions	174
66	Front-view of 64-Pin Connector on the Euro4	177
67	PowerPak Power Adapter	182
68	PowerPak Y-Type Null Modem Cable	183
69	ProPak-4E Power Cable	187
70	ProPak-4E Straight Through Serial Cable	188
71	ProPak-4E Null Modem Cable	189
72	ProPak-4E Strobe Cable	190

Tables

1	Enclosure Features Comparison	20
2	ProPak-LBplus Interface.....	24
3	NovAtel GPS Antenna Models	28
4	Voltage Input Ranges for GPSCards.....	29
5	Power Requirements for Enclosures	30
6	Default Serial Port Configurations	35
7	Available Strobe Signals on Receivers.....	37
8	FlexPak Status Indicators.....	38
9	ProPak-G2plus Status Indicators	39
10	ProPak-LBplus Status Indicators.....	39
11	Latency-Induced Extrapolation Error	71
12	Comparison of RT-2 and RT-20	81
13	Summary of RTK Messages and Expected Accuracy	81
14	RT-2 Performance: Static Mode	83
15	RT-2 Performance: Kinematic Mode	83
16	RT-2 Degradation With Respect To Data Delay.....	83
17	RT-20 Performance	85
18	NovAtel Logs for Rinex Conversion.....	94
19	Troubleshooting based on Symptoms	111
20	Resolving a Receiver Error Word	113
21	Resolving an Error in the Receiver Status Word	114
22	FlexPak COM1 Port Pin-Out Descriptions	129
23	FlexPak COM2 Port Pin-Out Descriptions.....	130
24	ProPak-G2plus Serial Port Pin-Out Descriptions	137
25	ProPak-G2plus I/O Port Pin-Out Descriptions.....	137
26	ProPak-LBplus Power Port Pin-Out Descriptions	145
27	ProPak-LBplus COM1 Port Pin-Out Descriptions	145
28	ProPak-LBplus COM2 Port Pin-Out Descriptions	146
29	ProPak-LBplus COM3 Port Pin-Out Descriptions	146
30	Static-Accumulating Materials	152
31	Voltage Input Ranges for GPSCards.....	156
32	GPSCard RF Input Connectors	156
33	GPSCard Power Inputs	156
34	Enclosure Power Inputs.....	157
35	Default Serial Port Configurations	157
36	PowerPak-4 Status Indicators	157
37	PowerPak-4E Status Indicators.....	157
38	ProPak-G2 Status Indicators	157
39	ProPak-G2 (DB-9 Version) Serial Port Pin-Out Descriptions	160
40	ProPak-G2 (LEMO Version) Serial Port Pin-Out Descriptions	160
41	ProPak-G2 (DB-9 Version) I/O Port Pin-Out Descriptions.....	161
42	PowerPak Serial Port Pin-Out Descriptions	181
43	PowerPak I/O Port Pin-Out Descriptions.....	181
44	ProPak-4E Serial Port Pin-Out Descriptions	186
45	ProPak-4E I/O Port Pin-Out Descriptions.....	186

Software License

BY INSTALLING, COPYING, OR OTHERWISE USING THE SOFTWARE PRODUCT, YOU AGREE TO BE BOUND BY THE TERMS OF THIS AGREEMENT. IF YOU DO NOT AGREE WITH THESE TERMS OF USE, DO NOT INSTALL, COPY OR USE THIS ELECTRONIC PRODUCT (SOFTWARE, FIRMWARE, SCRIPT FILES, OR OTHER ELECTRONIC PRODUCT WHETHER EMBEDDED IN THE HARDWARE, ON A CD OR AVAILABLE ON THE COMPANY WEB SITE) (hereinafter referred to as "Software").

1. License: NovAtel Inc. ("NovAtel") grants you a non-exclusive, non-transferable license (not a sale) to, where the Software will be used on NovAtel supplied hardware or in conjunction with other NovAtel supplied software, use the Software with the product(s) as supplied by NovAtel. You agree not to use the Software for any purpose other than the due exercise of the rights and licences hereby agreed to be granted to you.

2. Copyright: NovAtel owns, or has the right to sublicense, all copyright, trade secret, patent and other proprietary rights in the Software and the Software is protected by national copyright laws, international treaty provisions and all other applicable national laws. You must treat the Software like any other copyrighted material except that you may make one copy of the Software solely for backup or archival purposes (one copy may be made for each piece of NovAtel hardware on which it is installed or where used in conjunction with other NovAtel supplied software), the media of said copy shall bear labels showing all trademark and copyright notices that appear on the original copy. You may not copy the product manual or written materials accompanying the Software. No right is conveyed by this Agreement for the use, directly, indirectly, by implication or otherwise by Licensee of the name of NovAtel, or of any trade names or nomenclature used by NovAtel, or any other words or combinations of words proprietary to NovAtel, in connection with this Agreement, without the prior written consent of NovAtel.

3. Patent Infringement: NovAtel shall not be liable to indemnify the Licensee against any loss sustained by it as the result of any claim made or action brought by any third party for infringement of any letters patent, registered design or like instrument of privilege by reason of the use or application of the Software by the Licensee or any other information supplied or to be supplied to the Licensee pursuant to the terms of this Agreement. NovAtel shall not be bound to take legal proceedings against any third party in respect of any infringement of letters patent, registered design or like instrument of privilege which may now or at any future time be owned by it. However, should NovAtel elect to take such legal proceedings, at NovAtel's request, Licensee shall co-operate reasonably with NovAtel in all legal actions concerning this license of the Software under this Agreement taken against any third party by NovAtel to protect its rights in the Software. NovAtel shall bear all reasonable costs and expenses incurred by Licensee in the course of co-operating with NovAtel in such legal action.

4. Restrictions: You may not:

- (a) copy (other than as provided for in paragraph 2), distribute, transfer, rent, lease, lend, sell or sublicense all or any portion of the Software except in the case of sale of the hardware to a third party;
- (b) modify or prepare derivative works of the Software;
- (c) use the Software in connection with computer-based services business or publicly display visual output of the Software;
- (d) transmit the Software over a network, by telephone or electronically using any means (except when downloading a purchased up[grade from the NovAtel web site); or
- (e) reverse engineer, decompile or disassemble the Software.

You agree to keep confidential and use your best efforts to prevent and protect the contents of the Soft-

ware from unauthorized disclosure or use.

5. Term and Termination: This Agreement and the rights and licences hereby granted shall continue in force in perpetuity unless terminated by NovAtel or Licensee in accordance herewith. In the event that the Licensee shall at any time during the term of this Agreement: i) be in breach of its obligations hereunder where such breach is irremediable or if capable of remedy is not remedied within 30 days of notice from NovAtel requiring its remedy; then and in any event NovAtel may forthwith by notice in writing terminate this Agreement together with the rights and licences hereby granted by NovAtel. Licensee may terminate this Agreement by providing written notice to NovAtel. Upon termination, for any reasons, the Licensee shall promptly, on NovAtel's request, return to NovAtel or at the election of NovAtel destroy all copies of any documents and extracts comprising or containing the Software. The Licensee shall also erase any copies of the Software residing on Licensee's computer equipment. Termination shall be without prejudice to the accrued rights of either party, including payments due to NovAtel. This provision shall survive termination of this Agreement howsoever arising.

6. Warranty: NovAtel does not warrant the contents of the Software or that it will be error free. The Software is furnished "AS IS" and without warranty as to the performance or results you may obtain by using the Software. The entire risk as to the results and performance of the Software is assumed by you. See product enclosure, if any for any additional warranty.

7. Indemnification: NovAtel shall be under no obligation or liability of any kind (in contract, tort or otherwise and whether directly or indirectly or by way of indemnity contribution or otherwise howsoever) to the Licensee and the Licensee will indemnify and hold NovAtel harmless against all or any loss, damage, actions, costs, claims, demands and other liabilities or any kind whatsoever (direct, consequential, special or otherwise) arising directly or indirectly out of or by reason of the use by the Licensee of the Software whether the same shall arise in consequence of any such infringement, deficiency, inaccuracy, error or other defect therein and whether or not involving negligence on the part of any person.

8. Disclaimer and Limitation of Liability:

- (a) **THE WARRANTIES IN THIS AGREEMENT REPLACE ALL OTHER WARRANTIES, EXPRESS OR IMPLIED, INCLUDING ANY WARRANTIES OF MERCHANTABILITY OR FITNESS FOR A PARTICULAR PURPOSE. NovAtel DISCLAIMS AND EXCLUDES ALL OTHER WARRANTIES. IN NO EVENT WILL NovAtel's LIABILITY OF ANY KIND INCLUDE ANY SPECIAL, INCIDENTAL OR CONSEQUENTIAL DAMAGES, INCLUDING LOST PROFITS, EVEN IF NovAtel HAS KNOWLEDGE OF THE POTENTIAL LOSS OR DAMAGE.**
- (b) NovAtel will not be liable for any loss or damage caused by delay in furnishing the Software or any other performance under this Agreement.
- (c) NovAtel's entire liability and your exclusive remedies for our liability of any kind (including liability for negligence) for the Software covered by this Agreement and all other performance or non-performance by NovAtel under or related to this Agreement are to the remedies specified by this Agreement.

9. Governing Law: This Agreement is governed by the laws of the Province of Alberta, Canada. Each of the parties hereto irrevocably attorns to the jurisdiction of the courts of the Province of Alberta.

10. Customer Support: For Software UPDATES and UPGRADES, and regular customer support, contact the NovAtel GPS Hotline at 1-800-NOVATEL (U.S. or Canada only), or 403-295-4900, Fax 403-295-4901, e-mail to support@novatel.ca, website: <http://www.novatel.com> or write to:
NovAtel Inc.

Customer Service Dept.
1120 - 68 Avenue NE,
Calgary, Alberta, Canada T2E 8S5

Warranty Policy

NovAtel Inc. warrants that its Global Positioning System (GPS) products are free from defects in materials and workmanship, subject to the conditions set forth below, for the following periods of time:

OEM4-G2L, or OEM4-G2, GPSCard Receivers	One (1) Year
FlexPak, ProPak-G2plus, or ProPak-LBplus	One (1) Year
GPSAntenna™ Series	One (1) Year
Cables and Accessories	Ninety (90) Days
Computer Discs	Ninety (90) Days
Software Warranty	One (1) Year

Date of sale shall mean the date of the invoice to the original customer for the product. NovAtel's responsibility respecting this warranty is solely to product replacement or product repair at an authorized NovAtel location.

Determination of replacement or repair will be made by NovAtel personnel or by technical personnel expressly authorized by NovAtel for this purpose.

THE FOREGOING WARRANTIES DO NOT EXTEND TO (I) NONCONFORMITIES, DEFECTS OR ERRORS IN THE PRODUCTS DUE TO ACCIDENT, ABUSE, MISUSE OR NEGLIGENT USE OF THE PRODUCTS OR USE IN OTHER THAN A NORMAL AND CUSTOMARY MANNER, ENVIRONMENTAL CONDITIONS NOT CONFORMING TO NOVATEL'S SPECIFICATIONS, OR FAILURE TO FOLLOW PRESCRIBED INSTALLATION, OPERATING AND MAINTENANCE PROCEDURES, (II) DEFECTS, ERRORS OR NONCONFORMITIES IN THE PRODUCTS DUE TO MODIFICATIONS, ALTERATIONS, ADDITIONS OR CHANGES NOT MADE IN ACCORDANCE WITH NOVATEL'S SPECIFICATIONS OR AUTHORIZED BY NOVATEL, (III) NORMAL WEAR AND TEAR, (IV) DAMAGE CAUSED BY FORCE OF NATURE OR ACT OF ANY THIRD PERSON, (V) SHIPPING DAMAGE; OR (VI) SERVICE OR REPAIR OF PRODUCT BY THE DEALER WITHOUT PRIOR WRITTEN CONSENT FROM NOVATEL. IN ADDITION, THE FOREGOING WARRANTIES SHALL NOT APPLY TO PRODUCTS DESIGNATED BY NOVATEL AS BETA SITE TEST SAMPLES, EXPERIMENTAL, DEVELOPMENTAL, PREPRODUCTION, SAMPLE, INCOMPLETE OR OUT OF SPECIFICATION PRODUCTS OR TO RETURNED PRODUCTS IF THE ORIGINAL IDENTIFICATION MARKS HAVE BEEN REMOVED OR ALTERED. THE WARRANTIES AND REMEDIES ARE EXCLUSIVE AND ALL OTHER WARRANTIES, EXPRESS OR IMPLIED, WRITTEN OR ORAL, INCLUDING THE IMPLIED WARRANTIES OF MERCHANTABILITY OR FITNESS FOR ANY PARTICULAR PURPOSE ARE EXCLUDED. NOVATEL SHALL NOT BE LIABLE FOR ANY LOSS, DAMAGE, EXPENSE, OR INJURY ARISING DIRECTLY OR INDIRECTLY OUT OF THE PURCHASE, INSTALLATION, OPERATION, USE OR LICENSING OR PRODUCTS OR SERVICES. IN NO EVENT SHALL NOVATEL BE LIABLE FOR SPECIAL, INDIRECT, INCIDENTAL OR CONSEQUENTIAL DAMAGES OF ANY KIND OR NATURE DUE TO ANY CAUSE.

There are no user serviceable parts in the GPS receiver and no maintenance is required. When the status code indicates that a unit is faulty, replace with another unit and return the faulty unit to NovAtel Inc.

Before shipping any material to NovAtel or Dealer, please obtain a Return Material Authorization (RMA) number from the point of purchase. You may also visit our website at <http://www.novatel.com> and select *Support | Repair Request* from the side menu.

Once you have obtained an RMA number, you will be advised of proper shipping procedures to return any defective product. When returning any product to NovAtel, please return the defective product in the original packaging to avoid ESD and shipping damage.

Customer Service

Firmware Upgrades

Firmware upgrades are firmware releases, which increase basic functionality of the receiver from one model to a higher level model type. When available, upgrades may be purchased at a price, which is the difference between the two model types on the current NovAtel GPS Price List plus a nominal service charge.

Firmware upgrades are accomplished through NovAtel authorized dealers.

Contact your local NovAtel dealer first for more information. To locate a dealer in your area or if the problem is not resolved, contact NovAtel Inc. directly using one of the following methods:

Call the NovAtel GPS Hotline at 1-800-NOVATEL (U.S. & Canada), or 403-295-4900 (international)

Fax: 403-295-4901

E-mail: support@novatel.ca

Website: <http://www.novatel.com>

Write: NovAtel Inc., Customer Service Dept., 1120 - 68 Avenue NE, Calgary, AB., Canada, T2E 8S5

☒ Before contacting NovAtel Customer Service regarding software concerns, please do the following:

1. Issue a FRESET command

2. Log the following data to a file on your PC for 30 minutes

RXSTATUSB	once
RAWEPHEMB	onchanged
RANGEB	ontime 1
BESTPOSB	ontime 20
RXCONFIGA	once
VERSIONB	once

3. Send the file containing the log to NovAtel Customer Service, using either the NovAtel ftp site at <ftp://ftp.novatel.ca/incoming> or the support@novatel.ca e-mail address.

If there is a hardware problem that has not been resolved, please send a list of the troubleshooting steps you have taken and their result. See also *Chapter 9 on Page 111*.

Notice

The following notices apply to the ProPak-LB*plus*, ProPak-G2*plus* and FlexPak-G2L.

FCC NOTICE

This equipment has been tested and found to comply with the radiated and conducted emission limits for a Class B digital device, for both CISPR 22 and Part 15 of the FCC rules. These limits are designed to provide reasonable protection against harmful interference in a residential installation. This equipment generates, uses, and can radiate radio frequency energy and, if not installed and used in accordance with the instructions, may cause harmful interference to radio communications. However, there is no guarantee that interference will not occur in a particular installation. If this equipment does cause harmful interference to radio or television reception, which can be determined turning the equipment off and on, the user is encouraged to try to correct the interference by one or more of the following measures:

- Re-orient or relocate the receiving antenna
- Increase the separation between the equipment and the receiver
- Connect the equipment to an outlet on a circuit different from that to which the receiver is connected
- Consult the dealer or an experienced radio/TV technician for help

IMPORTANT: In order to maintain compliance with the limits of a Class B digital device, it is required to use properly shielded interface cables (such as Belden #9539 or equivalent) when using the serial data ports, and double-shielded cables (such as Belden #9945 or equivalent) when using the I/O strobe port.



WARNING: Changes or modifications to this equipment not expressly approved by NovAtel Inc. could result in violation of Part 15 of the FCC rules.

CE NOTICE

The enclosures carry the CE mark.



WARNING: This is a Class B product. In a domestic environment this product may cause radio interference in which case the user may be required to take adequate measures.

"Hereby, NovAtel Inc. declares that this ProPak-G2*plus*, ProPak-LB*plus* and FlexPak-G2L are in compliance with the essential requirements and other relevant provisions of Directive 1999/5/EC."

Electromagnetic Compatibility (EMC)

Common Regulatory Testing

- FCC, Part 15 Radiated Emissions, Class B
- EN 61000-6-1 Generic Immunity
 - EN 61000-6-3 Generic Emissions, Class B
- EN 61000-4-2 Electrostatic Discharge Immunity
- EN 61000-4-3 Radiated RF EM Field Immunity Test
- EN 61000-4-4 Electrical Fast Transient/Burst Test
- EN 61000-4-6 Conducted Immunity
- EN 61000-4-8 Magnetic Field Immunity
- ENV 50204 Radiated Immunity, Keyed Carrier, 900 MHz Phone Band

ProPak-G2plus Additional Testing

- EN 61000-6-2 Generic Immunity - Industrial
- EN 61000-4-5 Surge Immunity
- EN 61000-4-11 Voltage Dips and Interruptions
- IEC/EN 60950 Safety of Information Technology Equipment
- EN 60555-2 Harmonic Emissions
- EN 60555-3 Voltage Changes, Fluctuations and Flicker

FlexPak-G2L Additional Testing

- EN 61000-4-5 Surge Immunity
- IEC/EN 60950 Safety of Information Technology Equipment

ProPak-LBplus Additional Testing

- ISO 7637-1 Conducted Transients
- IEC/EN 60950 Safety of Information Technology Equipment

Lightning Protection Notice

1. Do not install the external antenna lines extra-building during a lightning storm.
2. A primary lightning protection device, from Polyphaser Corporation for example, must be provided by the operator/customer according to local building codes as part of the extra-building installation to ensure transient voltage levels of less than 600 V maximum.

ProPak-G2plus Warning

This product is capable of providing power output on pin 4 of its COM2 and AUX ports. COM1 pins 6 and 9 provide universal serial bus (USB) signals. Cross connecting a ProPak-G2plus using a null modem cable to COM1 from any serial port other than COM1 may damage the unit and void your warranty. To prevent this damage cross connect the receivers using COM2 or COM3.

WEEE Notice

If you purchased your ProPak-LB^{plus}, ProPak-G2^{plus} or FlexPak-G2L in Europe, please return it to your dealer or supplier at the end of its life. The objectives of the European Community's environment policy are, in particular, to preserve, protect and improve the quality of the environment, protect human health and utilise natural resources prudently and rationally. Sustainable development advocates the reduction of wasteful consumption of natural resources and the prevention of pollution. Waste electrical and electronic equipment (WEEE) is a regulated area. Where the generation of waste cannot be avoided, it should be reused or recovered for its material or energy. WEEE products may be recognised by their wheeled bin label.

Foreword

Congratulations!

Thank you for purchasing a NovAtel receiver. Whether you have bought a stand alone GPSCard or a packaged receiver you will have also received companion documents for the product. *Volume 1* will help you get the hardware operational and provide further general information. Afterwards, *Volume 2* will be your primary OEM4 family command and logging reference source.

Scope

The *OEM4 Family of Receivers User Manual - Volume 1* contains sufficient information on the installation and operation of the OEM4-G2L and OEM4-G2 GPSCards to allow you to effectively integrate and fully operate them. There is also information on the FlexPak, ProPak-G2*plus* and ProPak-LB*plus* enclosures. After the addition of accessories, user-supplied data communications equipment and a power supply, the receivers are ready to go.

The OEM4 family receivers utilize a comprehensive user-interface command structure, which requires communications through its communications (COM) ports. This manual is volume one of a two volume set. The second volume, the *Command and Log Reference*, lists and describes the various receiver commands and logs. Please remember that since each receiver is shipped from the distributor with a customer-specific list of features, some commands or logs may not be applicable to your model. Other supplementary manuals may be included to accommodate special models and software features with unique functionality. It is recommended that these documents be kept together for easy reference.

It is beyond the scope of this manual to provide details on service or repair. Please contact your local NovAtel dealer for any customer-service related inquiries, see *Customer Service on Page 12*.

User Manual Updates

This manual has been revised to include information on a new L-Band service. NovAtel Inc. has developed OEM4-G2L-based products to use the Canada-Wide Differential Global Positioning System (CDGPS), a free signal operated by the Canadian government. See *Enabling L-Band Positioning (ProPak-LBplus Only)* starting on *Page 47* and *L-Band Positioning* starting on *Page 74*.

The most up-to-date version of this manual set and any related addendum can be downloaded from the [Documentation Updates](#) section of www.novatel.com.

Prerequisites

The OEM4-G2L and OEM4-G2 are OEM products requiring the addition of an enclosure and peripheral equipment before becoming a fully functional GPS receiver. The installation chapters of this document provide information concerning the installation requirements and considerations for the GPSCards and their enclosures.

Conventions

The terms OEM4-G2 and OEM4-G2L will not be used in this manual unless a specific detail refers to it alone. The term receiver will infer that the text is applicable to an OEM4-G2L or OEM4-G2, either stand-alone or in an enclosure, unless otherwise stated.

1.1 Overview of the OEM4 Family

The OEM4 family is a group of high-performance GPS receivers capable of receiving and tracking the L1 C/A Code, L1 and L2 carrier phase, and L2 P Code (or encrypted Y Code) of up to 12 GPS satellites. The ProPak-LB*plus* also includes a second card which receives L-Band signals for differential corrections. With patented Pulse Aperture Correlator (PAC) technology and a powerful 32-bit processor, the OEM4 family receivers offer multipath-resistant processing at high data update rates. Excellent acquisition and re-acquisition times allow the receivers to operate in environments where very high dynamics and frequent interruption of signals can be expected.

In addition, the OEM4 family offers system integrators unparalleled flexibility in areas such as configuration and specification of output data and control signals. Multiple software models are available, allowing you to better fit the receiver to the application while maintaining the option for a compatible upgrade path.

The OEM4 family includes OEM4-G2/OEM4-G2L GPSCards and FlexPak, ProPak-G2*plus* and ProPak-LB*plus* enclosures. The GPSCards, which are provided as printed circuit boards, are ideal for custom integration. The enclosures above offer a complete solution, a protective enclosure that provides an interface to the GPSCard's power, data, and status signals.

1.1.1 Common Features

All OEM4 family receivers have the following features:

- 24 channel “all-in-view” parallel tracking
- Pulse Aperture Correlator (PAC) technology, which is described in the *Multipath* section of the *GPS+ Reference Manual*
- Fast reacquisition
- Fully field-upgradeable firmware
- Low power consumption
- 20 Hz raw data and position output rates

At a minimum, the following models are available for each receiver:

- L1 only
- L1/L2
- L1 plus RT-20
- L1/L2 plus RT-2
- L1 plus Satellite-Based Augmentation System (SBAS) support
- L1/L2 plus SBAS support

Those models with dual-frequency capabilities make the following possible:

- Longer baselines in differential positioning mode, due to the reduction of atmospheric errors
- Faster resolution of carrier-phase ambiguities when performing RTK positioning
- Enhanced positioning precision due to the additional measurements

1.2 GPSCards

The OEM4 family GPSCards consist of a single printed circuit board with integrated radio frequency (RF) and digital sections. They are designed for flexibility of integration and configuration. After installation with a power source, mounting structure, GPS antenna, and data communications equipment, NovAtel's GPSCards are ready for the most demanding surveying, positioning, and navigation applications.

Two different GPSCards, described in the sections that follow, are included in the OEM4 family:

- OEM4-G2L
- OEM4-G2

1.2.1 OEM4-G2L GPSCard

The OEM4-G2L provides the best features of the OEM4 family in a compact, low-power card. In addition to the functionality given in *Section 1.1.1 on Page 17*, the OEM4-G2L offers:

- 40% smaller than the OEM4-G2
- 15% less power consumption compared to the OEM4-G2 and 35% less than the original OEM4
- Two serial ports
- USB support (with firmware version 2.100 or higher)
- An external oscillator input
- Two mark inputs for triggering the output of logs on external events
- Programmable PPS output (with firmware version 2.100 or higher)
- Auxiliary strobe signals for status and synchronization
- Software load compatibility with other OEM4 family products

Included with the OEM4-G2L is a wrist-grounding strap to prevent ESD damage when handling the card and a CD containing NovAtel's GPS PC utilities and product documentation.

For technical specifications on the OEM4-G2L, please see *Section A.2, starting on Page 117*.

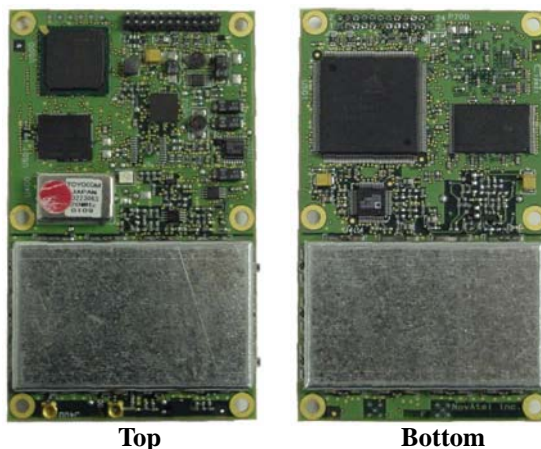

Figure 1: OEM4-G2L GPSCard

1.2.2 OEM4-G2 GPSCard

The OEM4-G2 is the second generation of the original OEM4. In addition to what is listed in *Section 1.1.1* on *Page 17*, the OEM4-G2 offers:

- An improved processor and memory
- 20% less power consumption compared to the OEM4
- Three serial ports, one of which is user-selectable for RS-232 or RS-422
- USB support (with firmware version 2.100 or higher)
- An external oscillator input
- Two mark inputs for triggering the output of logs on external events
- Programmable PPS output (with firmware version 2.100 or higher)
- Auxiliary strobe signals for status and synchronization
- On-board power conversion, eliminating the need for external power conditioning
- Voltage and temperature monitoring and reporting
- Software load compatibility with other OEM4 family products

Included with the OEM4-G2 is a wrist-grounding strap to prevent ESD damage when handling the card and a CD containing NovAtel's GPS PC utilities and product documentation.

For technical specifications on the OEM4-G2, please see *Section A.3*, starting on *Page 121*.

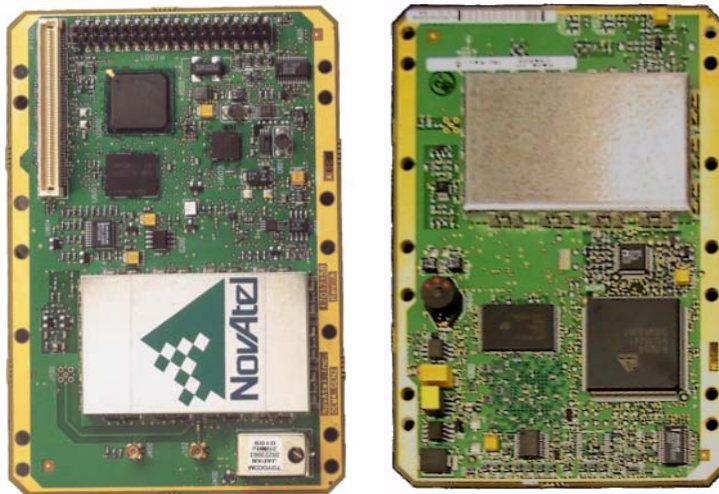

Top

Bottom

Figure 2: OEM4-G2 GPSCard

1.3 Enclosures

The OEM4 family GPSCards can be housed in a ProPak-G2*plus*, ProPak-LB*plus* or FlexPak enclosure to provide a complete receiver solution. When connected to an antenna and a power source, the enclosure and associated GPSCard together form a fully functioning GPS receiver.

The enclosures offer protection against environmental conditions and RF interference. In addition, they provide an easy-to-use interface to the GPSCard's data, power, and status signals. The enclosures offer GPS integrators an effective, self-contained system for indoor applications while also providing a rugged, water, shock, and vibration resistant housing for outdoor applications.

The table below provides a comparison between the features available on the various enclosures. The sections that follow give details on each of them.

Table 1: Enclosure Features Comparison

Feature	ProPak-G2 <i>plus</i>	ProPak-LB <i>plus</i>	FlexPak
GPSCard Supported	OEM4-G2	OEM4-G2	OEM4-G2L
Serial Ports	3 DB-9P connectors	3 Switchcraft connectors	2 Deutsch connectors
USB	Yes	Not available	Yes
Strobe Port	DB-9S connector	Switchcraft ^a connector	Deutsch ^b connector
Input Voltage	+7 to +18 V	+7 to +15 V	+6 to +18 V
L-Band Differential Corrections ^c	Not available	Yes	Not available
IMU Support ^d	Yes	Yes	Not available

- a. For the ProPak-LB*plus*, the strobes are available at the COM1 connector, which also provides RS-232 signals for one of the serial ports.
- b. If Pin# 1 on the Deutsch connector is grounded, the COM2 communications mode is set to RS-422.
- c. A subscription to the OmniSTAR or CDGPS service is required.
- d. If applicable, refer also to your *SPAN User Manual*

1.3.1 FlexPak

NovAtel's FlexPak is a rugged, waterproof housing for the OEM4-G2L positioning engine. As a result, the FlexPak can deliver centimeter-level positioning in a compact, lightweight enclosure. It provides dual-frequency positioning with a USB interface and an API option for supporting custom applications.

The FlexPak offers the following features:

- A shock and dust resistant enclosure
- Waterproof to IEC 60529 standard IPX7
- Low power consumption
- Two serial ports (COM1 is RS-232 and COM2 is RS-232/RS-422¹)
- USB support
- PPS output
- Configurable event inputs
- Indicators for position, communication status and power

The following accessories are included with the FlexPak:

- 1 12V power adapter cable
- 1 null modem serial cable with DB-9 connector
- 1 straight through serial cable with DB-9 connector
- 1 USB serial cable
- A CD containing NovAtel's GPS PC utilities and product documentation

For technical specifications on the FlexPak, please see *Section A.4, starting on Page 127*.



Figure 3: FlexPak Enclosure

1. If Pin# 1 on the Deutsch connector is grounded, the COM2 communications mode is set to RS-422.

1.3.2 ProPak-G2plus

The ProPak-G2plus provides a hardware interface between your equipment and the NovAtel OEM4-G2 GPSCard. It is a rugged, sealed enclosure that provides protection against adverse environments. It has DB-9 connectors to access data and status signals.

The ProPak-G2plus offers the following features:

- A mounting enclosure with a PCB interconnect back plane
- Three serial ports provided on three DB-9P connectors
- Auxiliary status and synchronization signals
- GPS antenna and power ports
- Indicators to provide power and communication status

The following accessories are included with the ProPak-G2plus:

- 1 12 V power adapter cable
- 2 or more data cables
- A CD containing NovAtel's GPS PC utilities and product documentation

For technical specifications on the ProPak-G2plus, please see *Section A.5, starting on Page 135*.



Figure 4: ProPak-G2plus Enclosure



Figure 5: ProPak-G2plus Rear Panel

1.3.3 ProPak-LBplus

The NovAtel ProPak-LBplus provides a hardware interface between your equipment and the NovAtel OEM4-G2 GPSCard. Additionally, within the ProPak-LBplus, an L-Band receiver provides correction data. As shown in *Figure 6*, the ProPak-LBplus is a rugged, sealed enclosure, suitable for adverse conditions.

☒ In order to receive L-Band corrections, a subscription to the OmniSTAR service, or use of the free Canada-Wide Differential Global Positioning System (CDGPS) signal, is required. See *Section 4.5* on *Page 47* or the *ProPak-LBplus Quick Start Guide*, provided with the receiver, for details.

In addition to support for L-Band positioning, the ProPak-LBplus provides the following:

- A rugged, environmentally-sealed enclosure
- 3 serial ports with Switchcraft-brand connectors
- GPS antenna and power ports
- Auxiliary strobe signals for status and synchronization
- Indicator to provide status information

The following accessories are included with the ProPak-LBplus:

- 1 12 V power adapter cable
- 3 straight through serial port cables
- A CD containing NovAtel's GPS PC utilities and product documentation







For technical specifications on the ProPak-LBplus, please see *Section A.6*, starting on *Page 143*.



Figure 6: ProPak-LBplus and Its Rear Panel

Figure 6, to the right, shows the six ports on the rear panel of the ProPak-LBplus that are labeled with icons. *Table 2* on *Page 24* provides information on these ports, including the name used to reference each of them throughout this manual.

Table 2: ProPak-LBplus Interface

Icon	Name	Description
	PWR	DC power input
	RES	Reserved
	COM1	RS232 signals and auxiliary strobe signals
	COM2	RS232 signals with optional flow control
	COM3	RS232 and general I/O signals
	ANT	Antenna connection

In addition to a NovAtel OEM4 family GPSCard, a complete GPS receiver system typically contains four other major components:

- A ProPak-G2*plus*, ProPak-LB*plus*, FlexPak or custom enclosure and wiring harness
- A GPS antenna (and optional LNA power supply)
- A power supply
- Data communications equipment

The overall system is represented in *Figure 7*. A brief description of each section follows the figure. Details of installation and set up are provided in *Chapter 3, Installation and Set Up on Page 28*.

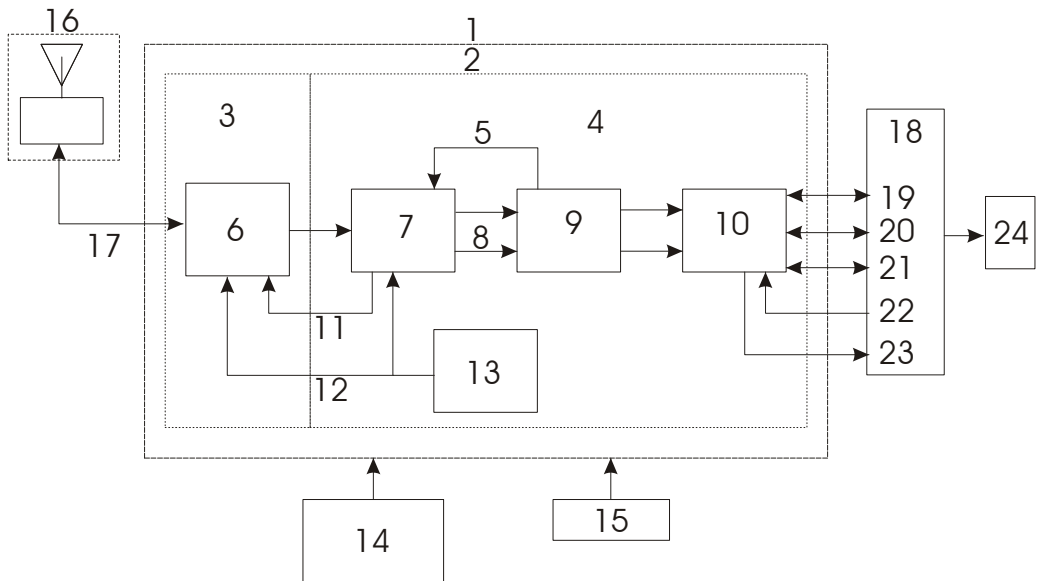

Figure 7: GPS Receiver System Functional Diagram

Reference	Description	Reference	Description
1	Enclosure	13	VCTCXO
2	GPSCard	14	Optional LNA Power
3	RF Section	15	Power Supply
4	Digital Section	16	GPS Antenna and LNA
5	Controls	17	RF and Power
6	RF-IF Sections	18	Data and Signal Processing
7	Signal Processor	19	COM1
8	Clock	20	COM2
9	22-Bit CPU	21	COM3
10	System I/O	22	Input Timing Signal
11	AGC	23	Output Timing Signal
12	Clock	24	USB Communication

2.1 GPSCard

NovAtel's GPSCards consist of a radio frequency (RF) and a digital electronics section.

2.1.1 Radio Frequency (RF) Section

The receiver obtains a filtered and amplified GPS signal from the antenna via the coaxial cable. The RF section performs the translation from the incoming RF signal to an IF signal usable by the digital section. It also supplies power to the active antenna's LNA through the coaxial cable while maintaining isolation between the DC and RF paths. The RF section can reject a high level of potential interference (for example, MSAT, Inmarsat, cellular phone, and TV sub-harmonic signals).

2.1.2 Digital Electronics Section

The digital section of the receiver receives a down-converted, amplified GPS signal which it digitizes and processes to obtain a GPS solution (position, velocity and time). The digital section consists of an analog-to-digital converter, a 32-bit system processor, memory, control and configuration logic, signal processing circuitry, serial peripheral devices, and supporting circuitry.

The digital section performs the translations and calculations necessary to convert the IF analog signals into usable position and status information. It also handles all I/O functions, including the auxiliary strobe signals, which are described in detail in *Section 3.3.1 on Page 36*. For input and output levels please see *Appendix A, Input/Output Strokes on Page 119* for the OEM4-G2L and *Page 124* for the OEM4-G2.

2.2 Enclosure and Wiring Harness

As discussed in *Section 1.3 on Page 20*, an enclosure is necessary to protect the GPSCard from environmental exposure and RF interference. If a ProPak-G2*plus*, ProPak-LB*plus* or FlexPak is not being used as the enclosure, a wiring harness will also be required to provide an interface to the GPSCard's antenna and power inputs and data and status signals.

2.3 GPS Antenna

The purpose of the GPS antenna is to convert the electromagnetic waves transmitted by the GPS satellites into RF signals. An active GPS antenna is required for the receiver to function properly. NovAtel's active antennas are recommended.

2.3.1 Optional LNA Power Supply

Power for the antenna LNA is normally supplied by the receiver. However, if a different type of antenna is required that is incompatible with this supply, then you could connect an external power source to the receiver.

External LNA power is not possible with a ProPak-G2*plus*, ProPak-LB*plus* or FlexPak receiver.

2.4 Principal Power Supply

A single external power supply capable of delivering 5 W is necessary to operate the receiver. See *Appendix A, Technical Specifications starting on Page 116* for details.



WARNING: If the voltage supplied is below the minimum specification, the receiver will suspend operation. If the voltage supplied is above the maximum specification, the receiver may be permanently damaged, voiding your warranty.

2.5 Data Communications Equipment

A PC or other data communications equipment is necessary to communicate with the receiver and, if desired, to store data generated by the receiver.

This chapter contains instructions and tips to set up your NovAtel receiver to create a GPS receiver system similar to that described in *Chapter 2, Receiver System Overview on Page 25*.

3.1 Additional Equipment Required

In order for the receiver to perform optimally, the following additional equipment is required:

- An interface for power, communications, and other signals and an enclosure to protect against the environment (if your receiver has been purchased as a GPSCard without an enclosure)
- A NovAtel GPS antenna
- A quality coaxial cable (and interconnect adapter cable as necessary)
- Data communications equipment capable of serial communications
- A serial cable (if not included with the receiver)
- A power supply
- A power cable (if not included with the receiver)



CAUTION: When the OEM4 family receiver is installed in a permanent location, such as in a building, it should be protected by a lightning protection device according to local building codes. See also *Warranty Policy on Page 11*.

3.1.1 Selecting a GPS Antenna

An active antenna is required because its low-noise amplifier (LNA) boosts the power of the incoming signal to compensate for the line loss between the antenna and the receiver.

NovAtel offers a variety of single and dual-frequency GPS antenna models, as indicated in the table below. All include band-pass filtering and an LNA. The GPS antenna you choose will depend on your particular application. Each of these models offer exceptional phase-center stability as well as a significant measure of immunity against multipath interference. Each one has an environmentally-sealed radome.

Table 3: NovAtel GPS Antenna Models

Models	Frequencies Supported
701	L1 only
702, 533, 532	L1 and L2
702-L	L1 and L2 plus L-Band

3.1.2 Choosing a Coaxial Cable

An appropriate coaxial cable is one that is matched to the impedance of the antenna and receiver being

used (50 ohms), and whose line loss does not exceed 10.0 dB. If the limit is exceeded, excessive signal degradation will occur and the receiver may not be able to meet its performance specifications. NovAtel offers a variety of coaxial cables to meet your GPS antenna interconnection requirements, including:

- 5, 15, or 30 m antenna cables with TNC male connectors on both ends (NovAtel part numbers C006, C016 and C032 respectively)
- 22 cm interconnect adapter cable with MMCX male and TNC female connectors (NovAtel part number GPS-C002)

Note that a conversion is required between the female MMCX connector on the OEM4-G2L and OEM4-G2 GPSCards, and the female TNC connector on Novatel’s GPS antennas.

Your local NovAtel dealer can advise you about your specific configuration. Should your application require the use of cable longer than 30 m you will find the application note *RF Equipment Selection and Installation* at our website, www.novatel.com, or you may obtain it from NovAtel Customer Service directly.

High-quality coaxial cables should be used because a mismatch in impedance, possible with lower quality cable, produces reflections in the cable that increase signal loss. Though it is possible to use other high-quality antenna cables, the performance specifications of the OEM4 family receivers are warranted only when used with NovAtel-supplied accessories.

3.1.3 Power Supply Requirements

This section contains information on the requirements for the input power to the receiver. See *Appendix A, Technical Specifications starting on Page 116* for more power supply specifications.



WARNING: If the voltage supplied is below the minimum specification, the receiver will suspend operation. If the voltage supplied is above the maximum specification, the receiver may be permanently damaged, voiding your warranty.

3.1.3.1 GPSCards

The OEM4-G2 GPSCard contains a DC to DC converter that is very tolerant to noise and ripple at its input. A tightly regulated input supply to the card is not required, as long as it falls within the given input range. A tightly regulated input supply to the OEM4-G2L GPSCard is required. The power supply used for any GPSCard should be capable of 5 W. The voltage input range for each GPSCard type is given in the table below.

Table 4: Voltage Input Ranges for GPSCards

GPSCard	Power Input Range
OEM4-G2L	+3.3 ± 0.15 VDC
OEM4-G2	+4.5 to +18 VDC

All members of the OEM4 family receivers are designed to prevent internal damage when subjected to a reverse polarity power connection. The OEM4-G2 also provides protection from short over



voltage events. It is recommended that appropriate fuses or current limiting be incorporated as a safety precaution on all power lines used. Use a sufficient gauge of wire to ensure that the voltage at the connector is within the GPSCard's requirements.

3.1.3.2 ProPak-G2plus, ProPak-LBplus or FlexPak Enclosures

The ProPak-G2plus, ProPak-LBplus and FlexPak enclosures are supplied with a 12V power adapter with a built-in slow-blow fuse for use with a standard 12 VDC power outlet. NovAtel's Aircraft Power Conditioner can also be used to provide further protection for your receiver.

If a different supply is desired, the table below provides the input range required as well as the type of connector required to mate with the receiver's power connector. The supply should be capable of 5 W.

Table 5: Power Requirements for Enclosures

Enclosure	Power Cable Connector Required	Power Input Range
FlexPak	3-pin Deutsch socket connector ^a labelled 	+6 to +18 VDC
ProPak-G2plus	4-pin LEMO socket connector ^a labelled <i>PWR</i>	+7 to +18 VDC ^b
ProPak-LBplus	2-pin Switchcraft socket connector ^a labelled 	+7 to +15 VDC

- See *Appendix C, Replacement Parts starting on Page 154* for connector part numbers.
- The power input range becomes +9 to +18 VDC when an IMU device is connected. To operate a complete SPAN system requires +12 to +18 VDC. If applicable, see the *SPAN Technology User Manual* for more information.

3.2 Installation Overview

Once you have selected the appropriate equipment, complete the following steps to set up and begin using your NovAtel GPS receiver.

- If your receiver has been provided as a GPSCard without an enclosure, install the card in an enclosure with a wiring harness, as described in *Section 3.2.1 on Page 31*.
- Mount the GPS antenna to a secure, stable structure, as described in *Section 3.2.2 on Page 34*.
- Connect the GPS antenna to the receiver using an antenna RF cable, using the information given in *Section 3.2.3 on Page 34*.
- Apply power to the receiver, as described in *Section 3.2.4 on Page 35*.
- Connect the receiver to a PC or other data communications equipment by following the information given in *Section 3.2.5 on Page 35*.

Figure 8 on the next page shows a typical set up for an enclosed receiver.

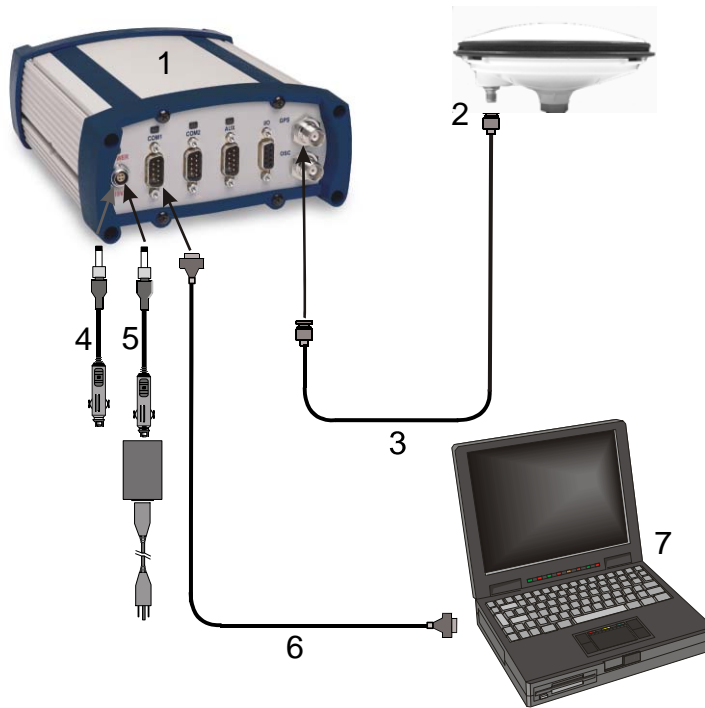

Figure 8: Typical Receiver Installation

Reference	Description
1	Receiver
2	GPSAntenna Model 702 or 701
3	RF Antenna Cable
4	12V Power Adapter Cable
5	Optional AC Adapter or Aircraft Power Conditioner
6	Null Modem Data Cable
7	Data Communications Equipment

3.2.1 Installing a GPSCard in a Wiring Harness and Enclosure

To install a GPSCard, begin with the following:

1. Ensure you are taking the necessary precautions against ESD, as described in *Section 3.2.1.1 on Page 32*.
2. Mount the GPSCard in a secure enclosure to reduce environmental exposure and RF interference, as described in *Section 3.2.1.2 on Page 32*.
3. Prepare a wiring harness to interface to the receiver’s data, status, and power signals using the information given in *Section 3.2.1.3 on Page 33*.

3.2.1.1 Electrostatic Discharge (ESD) Precautions

Electrostatic discharge is a leading cause of failure of electronic equipment components and printed circuit boards containing ESD-sensitive devices and components. It is imperative that ESD precautions be followed when handling or installing a GPSCard. Refer to the *Anti-Static Practices* section of the *GPS+ Reference Manual* for more information on ESD precautions.

Leave the GPSCard in its static-shielding bag or clamshell when not connected in its normal operating environment. When removing the GPSCard from the ESD protection, follow accepted standard anti-static practices. Failure to do so may cause damage to the GPSCard.

When you remove the GPSCard from the original packing box, it is recommended that you save the box and ESD protection for future storage or shipment purposes.



CAUTION

Remember:

- **Always wear a properly grounded anti-static wrist strap when handling the GPSCard.**
 - **Always hold the GPSCard by its corners or the RF shield, and avoid direct contact with any of the components.**
 - **Do not let the GPSCard come in contact with clothing at any time because the grounding strap cannot dissipate static charges from fabrics.**
 - **Failure to follow accepted ESD handling practices could cause damage to the GPSCard.**
 - **Warranty may be voided if equipment is damaged by ESD.**
-
-

3.2.1.2 Mounting the Printed Circuit Board

The OEM4 family GPSCards are OEM products and therefore the printed circuit board is provided without a housing structure. This allows flexibility in creating a mounting environment to suit particular product and marketing requirements. The mounting and enclosure should provide the following:

- mounting of external connectors
- protection from hostile physical environments (for example, rain, snow, sand, salt, water, extreme temperatures)
- electromagnetic shielding to protect from hostile RF environments (for example, nearby transmitters)
- electromagnetic shielding so that the final product itself conforms to RF emissions specifications
- protection from ESD (refer to the *Anti-Static Practices* section of the *GPS+ Reference Manual*)

The GPSCard can be held in place by screws. Please see *Appendix A, Technical Specifications starting on Page 116* for mechanical drawings.

3.2.1.3 Preparing the Data, Signal & Power Harness

The wiring harness serves the following interconnect functions:

- provide access to the serial communications ports
- provide access to input and output timing strobes
- provide power input(s)
- provide access to control signals

For all GPSCards, the power, status, and data inputs and outputs are accessed from a single connector. Therefore, the harness must be designed to mate with this connector.

Figure 9 shows that the OEM4-G2L uses a 24-pin dual-row male connector with 0.5 mm square pins and 2 mm spacing for the data, power, and status signals. The pin out for this connector is specified in Section A.2 starting on Page 117. The RF connector on the OEM4-G2L is an MMCX female.

As shown in Figure 10, the OEM4-G2 uses a 40-pin dual-row male connector with 0.25” square pins and 0.1” spacing for the data, power, and status signals. The pin out for this connector is specified in Section A.3 starting on Page 121. The RF connector is an MMCX female.

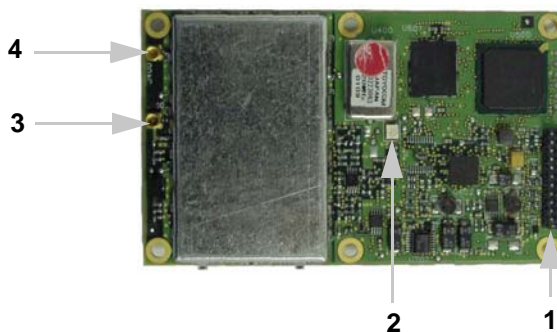

Figure 9: OEM4-G2L Connector and Indicator Locations

Reference	Description
1	Power, data, and signal connector (24 pin dual row male connector with 0.5 mm square pins and 2 mm spacing)
2	LED status indicator
3	RF signal input and LNA power output (MMCX female connector)
4	External oscillator input (MMCX female connector)

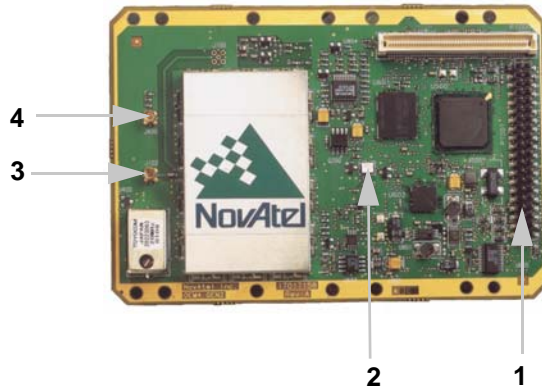

Figure 10: OEM4-G2 Connector and Indicator Locations

Reference	Description
1	Power, data, and signal connector (40 pin dual row male connector with 0.025" square pins and 0.1" spacing)
2	LED status indicator
3	RF signal input and LNA power output (MMCX female connector)
4	External oscillator input (MMCX female connector)

3.2.2 Mounting the GPS Antenna

Once the GPSCard is installed in a wiring harness and enclosure, the antenna to be used with the receiver must be mounted. The GPS receiver has been designed to operate with any of the NovAtel single-frequency or dual-frequency GPS antenna models. See *Section 3.1.1 on Page 28* for more information.

When installing the antenna system:

- Choose an antenna location that has a clear view of the sky so that each satellite above the horizon can be tracked without obstruction. (Refer to the *Multipath* section in the *GPS+ Reference Manual*).
- Mount the antenna on a secure, stable structure capable of safe operation in the specific environment.

3.2.3 Connecting the Antenna to the Receiver

Connect the antenna to the receiver using high-quality coaxial cable, as discussed in *Section 3.1.2 on Page 28*.

The ProPak-G2*plus*, ProPak-LB*plus* and FlexPak enclosures provide a TNC female connector, which can be connected to the antenna directly with any of NovAtel's coaxial cables. For the GPSCards, an interconnect adapter cable is required to convert the TNC male end of the coaxial cable to the card's MMCX female RF input connector. The location of the RF connector for each of the GPSCards is shown in *Figure 9* and *Figure 10*.

3.2.4 Applying Power to the Receiver

Connect the power supply, set to the voltage given in *Section 3.1.3 on Page 29*, to the wiring harness created previously.

For a ProPak-G2*plus*, ProPak-LB*plus* or FlexPak enclosure, connect the power supply to the port described in *Table 5, Power Requirements for Enclosures on Page 30*.

3.2.5 Connecting Data Communications Equipment

In order to communicate with the receiver by sending commands and obtaining logs, a connection to some form of data communications equipment is required. The default configuration available for each of the receiver types is given in the table below. However, if desired, on some of the receivers, the serial ports can be factory configured for either RS232, RS422, or LVTTL operation. Consult NovAtel Customer Service for more details on factory configuration. See *Appendix A, Technical Specifications starting on Page 116* for data connection details.

Table 6: Default Serial Port Configurations

Receiver	COM1	COM2	COM3
OEM4-G2L	RS-232	LVTTL	Not available
OEM4-G2	User-selectable as RS-232 or RS-422. See <i>Section 3.2.5.1 on Page 36</i> for more information.	RS-232	LVTTL
FlexPak ^a	RS-232	RS-232 / RS-422	Not available
ProPak-G2 <i>plus</i>	RS-232	RS-232	RS-232
ProPak-LB <i>plus</i>	RS-232	RS-232	RS-232

a. If Pin# 1 on the Deutsch connector is grounded, the COM2 communications mode is set to RS-422.

Each port may support some, or all, of the following signals:

- Data Terminal Ready (DTR)
- Clear To Send (CTS)
- Transmitted Data (TXD)
- Request To Send (RTS)
- Received Data (RXD)
- Data Carrier Detect (DCD)

On many of the receivers, extra control lines are provided on COM2 for use with modems or other differential correction data links.

The ProPak-G2*plus*, ProPak-LB*plus* and FlexPak enclosures are Data Terminal Equipment (DTE) so that TXD, RTS and DTR are outputs while RXD, CTS and DCD are inputs. A null modem cable is required to connect to another DTE like a terminal or a PC.

The port settings (bit rate, parity, and so on) are software-configurable. These are further described in *Chapter 4, Operation on Page 41*. See *Appendix A, Technical Specifications starting on Page 116* for further information on data communications characteristics.

3.2.5.1 User-Selectable Port Configuration (OEM4-G2 Only)

The OEM4-G2 offers a user-selectable configuration for the COM1 port. The configuration is selected using the USERIO1 pin. By default, RS-232 is selected as the USERIO1 input is set low by an internal pull-down resistor. To select RS-422, upon startup apply 3.3 V to USERIO1 or tie it to pin 38 of the 40-pin connector.

Pin 38 on the 40-pin connector is usually an ERROR indicator, and during normal GPSCard operations is set LOW, but for a few seconds during GPSCard initialization, immediately after applying power to the GPSCard, this pin is set HIGH at 3.3 Volts. It drops to LOW a few seconds later when the GPSCard has been fully booted up, around the time that the [COMx] prompt is output from the GPSCard on all COM ports.

USERIO1 needs to be initialized HIGH during this initial boot-up phase in order to set up the COM1 port for RS-422 mode. Therefore, set pin 38 ERROR to HIGH to provide a convenient 3.3 V source that is used to trigger the USERIO1 to set the COM1 port to RS-422 mode. See also *Page 36* for note.

☒ Your OEM4-G2 hardware revision must be 3.00 or later and you must be running firmware 2.110 or later in order to use this RS-422 feature on the COM1 port of the OEM4-G2 GPSCard.

3.3 Additional Features and Information

This section contains information on the additional features of the OEM4 family receivers, which may affect the overall design of your receiver system.

3.3.1 Strobes

On many of the OEM4 family receivers, a set of inputs and outputs that provide status and synchronization signals are given. These signals are referred to as strobes. As shown in *Table 7 on Page 37*, not all strobe signals are provided on all receivers. However, for those products for which strobes are available, you may want to design your installation to include support for these signals.

The OEM4-G2L provides 6 TTL-compatible I/O strobes, which can be located on the connector shown in *Figure 39, OEM4-G2L Board Dimensions on Page 117*. The OEM4-G2 GPSCard has 9 TTL-compatible I/O strobe lines. See *Figure 41, OEM4-G2 Board Dimensions on Page 121*.

The ProPak-G2*plus* provides strobe signals at its I/O port, as described in *Table 25 on Page 137*. Access to the ProPak-LB*plus* strobe signals is obtained through the COM1 port, which is labelled $\frac{X}{I_2}$. See *Table 27 on Page 145* for more information on the ProPak-LB*plus* strobes.

Strobe signals include an input and several outputs as described below:

- Mark Input (Event1, Event2) A pulse on this input triggers certain logs to be generated. (Refer to the MARKPOS and MARKTIME logs and ONMARK trigger in *Volume*

- Measure Output (MSR)
- Pulse Per Second Output (PPS)
- Position Valid Output (PV)
- Error Output (ERROR)
- LED Red Output (STATUS_RED)
- LED Green Output (STATUS_GREEN)
- Variable Frequency (VARF)

2 of this manual set). For the OEM4-G2 and OEM4-G2L, the polarity is configurable (refer to the MARKCONTROL command in *Volume 2* of this manual set). The mark inputs have 10K pull up resistors to 3.3 V and are falling edge triggered. Falling edge is synchronized with internal GPS measurements.

A pulse for which the trailing edge is synchronized with GPS time. For the OEM4-G2 and OEM4-G2L, the polarity and period is configurable using the PPSCONTROL command (refer to *Volume 2* of this manual set).

High when good GPS position and time solution.
High when a receiver hardware failure is detected.

Hardware failure when on or pulsing.

Normal operation when pulsing at 1 Hz.

Programmable output range from 0 to 20 MHz (refer to FREQUENCYOUT in *Volume 2* of this manual set).

See *Appendix A, Technical Specifications starting on Page 116*, for further information on the strobe signal characteristics.

Table 7: Available Strobe Signals on Receivers

Signal	EVENT1	EVENT2	MSR	PPS	PV	ERROR	STATUS_RED	STATUS_GREEN	VARF
OEM4-G2L	Pin 8	Pin 7	Not available	Pin 4	Pin 10	Pin 9	Not available	Not available	Pin 3
OEM4-G2	Pin 11	Pin 31	Pin 32	Pin 7	Pin 2	Pin 38	Pin 13	Pin 28	Pin 9
FlexPak	Pin 4	Pin 6	Not available	COM1/ COM2 port, Pin 10	Not available	COM1/ COM2 port, Pin 13	Not available	Not available	Not available
ProPak-G2plus	I/O port, pin 4	I/O port, pin 6	I/O port, pin 3	I/O port, pin 2	I/O port, pin 5	I/O port, pin 8	Not available	Not available	I/O port, pin 1
ProPak-LBplus	COM1 port, pin 2 ^a	Not available	Not available	COM1 port, pin 1 ^a	Not available	Not available	Not available	Not available	Not available

a. The ProPak-LBplus COM1 port is RS-232 and also provides access to strobe signals.

3.3.2 USB (OEM4-G2/-G2L, FlexPak and ProPak-G2plus Only)

The OEM4-G2/-G2L and FlexPak receivers running firmware version 2.100 or higher, along with the accompanying NovAtel USB drivers for Windows 2000 and Windows XP, provide three virtual serial ports over a single USB connection using USB D(+) and USB D(-) signals. See *Figure 40 on Page 120* and *Figure 42 on Page 125* for pin-out information. The ProPak-G2plus, with 2.200 firmware or higher, provides a USB connection through its COM1 port, see *Table 24 on Page 137*.

These three virtual serial ports, identified by the GPSCard as USB1, USB2, and USB3, are available to existing Windows applications which use COM ports to communicate (for example, HyperTerminal and GPSolution4). The NovAtel USB drivers assign COM port numbers sequentially following any existing ports on the PC. For example, if a PC has COM1 and COM2 ports, the NovAtel USB drivers will assign COM3 to USB1, COM4 to USB2, and COM5 to USB3.

-
- ☒ The assignment of COM port numbers is tied to the USB port on the PC. This allows you to switch receivers without Windows assigning new COM ports. However, if you connect the receiver to a different USB port, Windows detects the receiver's presence on that USB port and assigns three new COM port numbers.
-

The NovAtel USB Configuration Utility installed with the NovAtel USB drivers allows you to change the COM port numbers assigned to the virtual serial ports. The USB drivers, along with installation instructions, are available on the OEM4 Family CD by selecting *USB Support* from the main menu. You can also check for updates to the drivers or release notes on our website at www.novatel.com.

3.3.3 Status Indicators

Many of the OEM4 family receivers have LED indicators that provide the status of the receiver. The GPSCards have a single indicator, which is shown in *Figure 9 on Page 33* for the OEM4-G2L, and *Figure 10 on Page 34* for the OEM4-G2. The LED blinks green on and off at approximately 1 Hz to indicate normal operation. If the indicator is red, then the receiver is not working properly. The operation of this indicator is further described in *Section 8.6 on Page 109*.

The FlexPak, ProPak-G2plus and ProPak-LBplus provide the status indicators shown in *Tables 8 - 10*.



Table 8: FlexPak Status Indicators

Indicator	Indicator Color	Status
COM1	Green	Data is being transmitted from COM1
	Red	Data is being received on COM1
COM2	Green	Data is being transmitted from COM2
	Red	Data is being received on COM2
ANT	Red	Hardware error.
	Green	Valid position computed.
PWR	Red	The receiver is powered

Table 9: ProPak-G2plus Status Indicators

Indicator	Indicator Color	Status
COM1	Green	Data is being transmitted from COM1
	Red	Data is being received on COM1
COM2	Green	Data is being transmitted from COM2
	Red	Data is being received on COM2
AUX	Green	Data is being transmitted from COM3
	Red	Data is being received on COM3
PWR	Red	The receiver is powered

Table 10: ProPak-LBplus Status Indicators

Indicator	Indicator Color	Status
	Red	Hardware error.
	Green	Valid position computed.
	Red	The receiver is powered.

3.3.4 External Oscillator (OEM4-G2/-G2L and ProPak-G2plus Only)

For certain applications requiring greater precision than what is possible using the on-board 20 MHz, voltage-controlled, temperature-compensated crystal oscillator (VCTCXO), you may wish to connect the OEM4-G2L or OEM4-G2 to an external, high-stability oscillator. The external oscillator can be either 5 MHz or 10 MHz.

Installation consists of connecting a cable from the external oscillator to the receiver’s external oscillator input connector.

For the ProPak-G2plus, with firmware 2.200 or higher, the BNC external oscillator port, labeled OSC, is used. See *Figure 5, ProPak-G2plus Rear Panel on Page 22*.

For the OEM4-G2L and OEM4-G2, an MMCX female connector is used, as shown in *Figure 9 on Page 33* and *Figure 10 on Page 34*, respectively. The receiver does not have to be powered down during this procedure. If you are handling the OEM4-G2 or OEM4-G2L directly, anti-static practices must be observed.

Once the external oscillator has been installed, the EXTERNALCLOCK command must be issued to define the clock model (for example, cesium, rubidium or ovenized crystal). If the input clock rate is 5 MHz, the EXTERNALCLOCK command must be issued to change the 10 MHz default rate. For more information on this command, please refer to *Volume 2* of this manual set.

3.3.5 External Antenna LNA Power (OEM4-G2 Only)

For the OEM4-G2 it is possible to supply power to the LNA of an active antenna either from the antenna port of the GPSCard itself or from an external source. The internal antenna power supply of the GPSCards can produce +4.75 to +5.10 VDC at up to 100 mA. This meets the needs of any of NovAtel's dual-frequency GPS antennas, so, in most cases, an additional LNA power supply is not required.

If a different antenna is used whose LNA requires voltage capacity beyond what the receiver can produce, then the external LNA power option must be utilized. This simply requires setting a voltage supply between +12 and +30 VDC, 100 mA maximum, and connecting it to pin 40 of the 40-pin connector on the OEM4-G2. See also *Appendix A, RF Input / LNA Power Output on Page 118*.

In either case, the LNA power is fed to the antenna through the same coaxial cable used for the RF signals. The internal LNA power source should be disabled using the ANTENNAPOWER command. Refer to *Volume 2* of this manual set for more information on this command.

External LNA power is not possible with an OEM4-G2L, ProPak-G2plus, ProPak-LBplus or FlexPak receiver.



CAUTION

No warranty is made that the receiver will meet its performance specifications if a non-NovAtel antenna is used.

3.3.6 Mounting Bracket (ProPak-G2plus and ProPak-LBplus Only)

Along with the ProPak-G2plus and ProPak-LBplus enclosures, mounting kits have been provided to facilitate mounting the receivers to a surface. This section provides information on how to mount the receivers.

-
- ☒ The mounting kits are not designed for use in high-dynamics or high-vibration environments. Contact NovAtel Customer Service if your application requires the ProPak-G2plus or ProPak-LBplus to be mounted in these types of environments.
-

3.3.6.1 ProPak-G2plus and ProPak-LBplus

To install the mounting bracket provided with the ProPak-G2plus and ProPak-LBplus, refer to the instructions provided with the mounting kit. *Page 144* provides the dimension information for the bracket.

Before operating the receiver for the first time, ensure that you have followed the installation instructions in *Chapter 3, Installation and Set Up on Page 28*. The following instructions are based on a configuration such as that shown in *Figure 11, Typical Operational Configuration*. It is assumed that a personal computer is used during the initial operation and testing for greater ease and versatility.

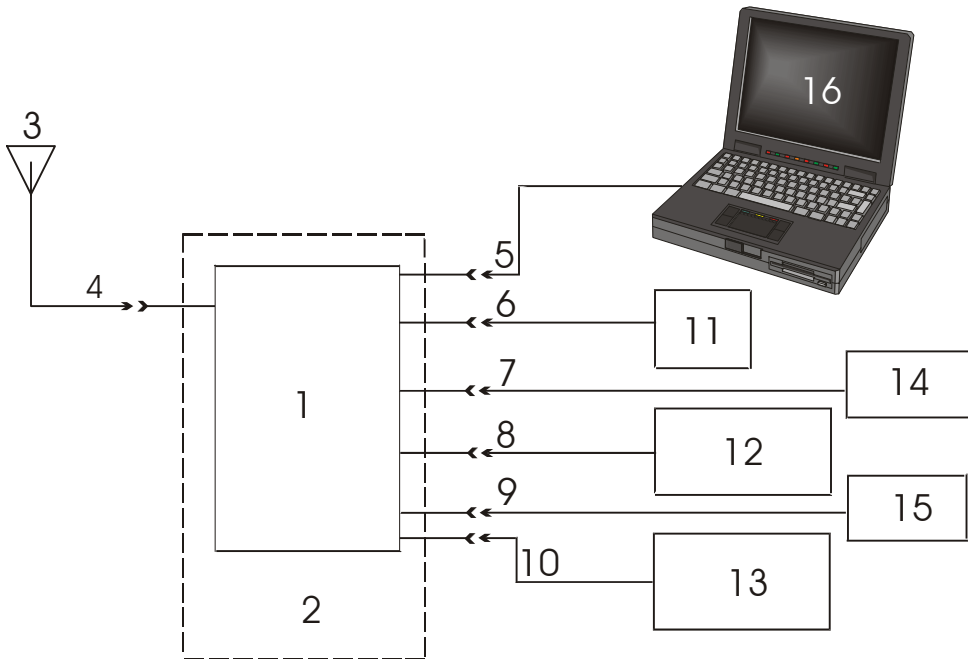

Figure 11: Typical Operational Configuration

Reference	Description	Reference	Description
1	GPSCard	9	External Oscillator Signal
2	OEM Enclosure	10	Power
3	Antenna Model 701,702,532, 533	11	Radio
4	GPS Signal	12	Data Logger or Rover Stn.
5	COM1 Signal	13	External DC Power Source
6	COM2 Signal	14	USB Device
7	USB Signal	15	External Oscillator
8	COM3 Signal	16	PC or Base Station

4.1 Communications with the Receiver

Communication with the receiver is straightforward, and consists of issuing commands through the communication ports from an external serial communications device. This could be either a terminal or an IBM-compatible PC that is directly connected to the receiver serial port using a null modem cable. If you are using an RTK radio it connects to the receiver's COM port by means of the radio serial cable supplied with the receiver. For information about commands and logs that are useful for basic operation of the receiver, refer to *Volume 2, Command and Log Reference*, of this manual set.

4.1.1 Serial Port Default Settings

The receiver communicates with your PC or terminal via a serial port. For communication to occur, both the receiver and the operator interface have to be configured properly. The receiver's COM1, COM2 and COM3 default port settings are as follows:

- **9600 bps, no parity, 8 data bits, 1 stop bit, no handshaking, echo off**

Changing the default settings requires using the *COM* command, which is described in *Volume 2* of this manual set. It is recommended that you become thoroughly familiar with the commands and logs detailed in *Volume 2* to ensure maximum utilization of the receiver's capabilities.

The data transfer rate you choose will determine how fast information is transmitted. Take for example a log whose message byte count is 96. The default port settings will allow 10 bits/byte. It will therefore take 960 bits per message. To get 10 messages per second then will require 9600 bps. Please also remember that even if you set the bps to 9600 the actual data transfer rate will be less and depends on the number of satellites being tracked, filters in use, and idle time. It is therefore suggested that you leave yourself a margin when choosing a data rate.



CAUTION: Although the receiver can operate at data transfer rates as low as 300 bps, this is not desirable. For example, if several data logs are active (that is, a significant amount of information needs to be transmitted every second) but the bit rate is set too low, data will overflow the serial port buffers, cause an error condition in the receiver status and result in lost data.

4.1.2 Communicating Using a Remote Terminal

One method of communicating with the receiver is through a remote terminal. The receiver has been pre-wired to allow proper RS232 interface with your data terminal. To communicate with the terminal the receiver only requires the RX, TX, and GND lines to be used. Handshaking is not required, although it can optionally be used. Ensure the terminal's communications set-up matches the receiver's RS232 protocol.

4.1.3 Communicating Using a Personal Computer

An IBM-compatible PC can be set up to emulate a remote terminal as well as provide the added flexibility of creating multiple-command batch files and data logging storage files. Any standard communications software package that emulates a terminal can be used to establish bidirectional communications with the receiver. No particular terminal type is assured. All data is sent as raw

characters.

You can create command batch files using any text editor; these can then be directed to the serial port that is connected to the receiver using a communications software package. This is discussed later in this chapter.

4.2 Getting Started

Included with your receiver are NovAtel's GPSolution and Convert programs. GPSolution is a Microsoft Windows-based graphical user interface which allows you to access the receiver's many features without struggling with communications protocol or writing special software. The Convert utility is a Windows-based utility that allows you to convert between file formats, and strips unwanted records for data file compilation. See *Chapter 7, PC Software and Firmware on Page 89* for more information on the GPSolution and Convert programs.

4.2.1 Starting the Receiver

The receiver's software resides in read-only memory. As such, the unit "self-boots" when turned on and undergoes a complete self-test. If an error condition is detected during a self-test, the self-test status word would change; this self-test status word can be viewed in the header of any data output log. Refer to the chapter on *Messages* in *Volume 2* of this manual set for header information. If a persistent error develops, please contact your local NovAtel dealer first. If the problem is still unresolved, please contact NovAtel directly through any of the methods in the Customer Service section at the beginning of this manual on *Page 12*.

When the receiver is first turned on, no activity information is transmitted from the COM ports except for the port prompt. The external data communications equipment screen will display one of these three messages:

[COM1] *if connected to COM1 port,*

[COM2] *if connected to COM2 port,*

or

[COM3] *if connected to COM3 port*

Any of these prompts indicate that the receiver is ready and waiting for command input.

Commands are typed at the interfacing terminal's keyboard, and executed after issuing a carriage return command which is usually the same as pressing the terminal's <Enter> key.

An example of a response to an input command is the FIX POSITION command. It can be entered:

```
[COM2] FIX POSITION 51.11635 -114.0383 1048.2 [Carriage Return]
<OK
```

The above example illustrates command input to the receiver's COM2 port which sets the position of the base station receiver in differential operation. Confirmation that the command was actually accepted is the appearance of <OK>.

If a command is incorrectly entered, the receiver will respond with "<Invalid Message ID>" (or a more detailed error message).

For more information on the various commands and logs please refer to the user manual entitled *Volume 2, Command and Log Reference*, of this manual set.

WARNING: Ensure the Control Panel's Power Settings on your PC are not set to go into Hibernate or Standby modes. Data will be lost if one of these modes occurs during a logging session.

4.2.2 Remote Terminal, PC and GPS Receiver

In addition to GPSolution, you can use a terminal program. Examples of how to use a DOS or Microsoft terminal window follows. For this example, consider a situation where a PC's appropriately-configured COM1 port is connected to the receiver's COM1 port, and where a remote terminal is connected to the receiver's COM2 port.

4.2.2.1 DOS

One way to initiate multiple commands and logging from the receiver is to create DOS boot-up command files relating to specific functions. This will save time when you want to duplicate test situations and minimize set-up time. Any convenient text editor can be used to create command text files.

1. Open a text editor on the PC and type in the command strings to be sent to the receiver upon start up. For example:

```
log com2 bestposa ontime 1
log com2 rangea ontime 1
log com2 rxstatusa onchanged
log com2 psrdopa onchanged
log com2 gpsephema onchanged
log com2 almanaca onchanged
log com2 rxconfiga once
```

-
- ☒ 1. Ensure you have used a carriage return (hit the enter key) after typing the last line.
 2. If you wish these to become part of the permanent configuration of the card, rather than just using them on boot-up, enter the SAVECONFIG command as the last line.
-
2. Save this with a convenient file name (for example, C:\GPS\BOOT1.TXT) and exit the text editor.
 3. Use the DOS *copy* command to direct the contents of the BOOT1.TXT file to the PC's COM1 port:

```
C:\GPS>copy boot1.txt com1
1 file(s) copied
C:\GPS>
```

4. The receiver is now initialized with the contents of the BOOT1.TXT command file, and logging is directed from the receiver's COM2 port to the remote terminal.

4.2.2.2 Microsoft Windows

As any text editor or communications program can be used for these purposes, the use of Windows 95 is described only as an illustration. The following example shows how Windows 95 accessory programs *Notepad* and *HyperTerminal* can be used to create a boot-file on a PC, and send it to the OEM4. It is assumed that the PC's serial port COM1 is connected to the receiver's COM1 port, and that a remote terminal is connected to the receiver's COM2 port.

1. Open *Notepad* and type in the command strings to be sent to the receiver upon start up. For example:

```
log com2 bestposa ontime 1
log com2 rangea ontime 1
log com2 rxstatusa onchanged
log com2 psrdopa onchanged
log com2 gpsephema onchanged
log com2 almanaca onchanged
log com2 rxconfiga once
```

-
- ☒ 1. Ensure you have used a carriage return (hit the enter key) after typing the last line.
 2. If you wish these to become part of the permanent configuration of the card, rather than just using them on boot-up, enter the SAVECONFIG command as the last line.
-

2. Save this with a convenient file name (for example, C:\GPS\BOOT.TXT) and exit *Notepad*.
3. Ensure that the *HyperTerminal* settings are correctly set up to match the settings with the receiver's communications protocol. These settings can be saved (for example, C:\GPS\OEMSETUP.HT) for use in future sessions. You may wish to use XON / XOFF handshaking to help prevent loss of data.
4. From the **Transfer** menu, use the **Send text file** selection to locate this file to be sent to the receiver. Once you double-click on the file or select *Open*, *HyperTerminal* will send the file to the receiver.

4.3 Transmitting and Receiving Corrections

Corrections are transmitted from a base station to a rover station to reduce or eliminate errors introduced by system biases, as described in *Section 6.1.1, GPS System Errors on Page 66*. In most cases you will need to provide a data link between the base station and rover station (two NovAtel receivers) in order to receive corrections. Exceptions are the SBAS and L-Band capable receivers. However, if you wish to use other types of corrections for these receivers, a data link must be provided. Generally a link capable of data throughput at a rate of 2400 bits per second or higher is sufficient for the examples shown below.

Next you need to pre-configure the base and rover site receivers before the units are used in your application. At the base station, enter the following commands:

```
interfacemode port rx_type tx_type
fix position latitude longitude height
log port message [trigger [period]]
```

For example:

```

RTCA      interfacemode com2 none rtca
            fix position 51.11358042 -114.04358013 1059.4105
            log com2 rtcaobs ontime 2
            log com2 rtcaref ontime 10
            log com2 rtca1 ontime 10 3
            log com2 rtcaephem ontime 10 7

RTCM      interfacemode com2 none rtcm
            fix position 51.11358042 -114.04358013 1059.4105
            log com2 rtcm3 ontime 10
            log com2 rtcm22 ontime 10
            log com2 rtcm1819 ontime 2
            log com2 rtcm1 ontime 10 5

RTCMV3    interfacemode com2 none rtcmv3
            fix position 51.11358042 -114.04358013 1059.4105
            log com2 rtcm1006 ontime 3
            log com2 rtcm1002 ontime 10

CMR       interfacemode com2 none cmr
            fix position 51.11358042 -114.04358013 1059.4105
            log com2 cmrobs ontime 2
            log com2 cmrref ontime 10
            log com2 cmrdesc ontime 10 5

```

At the rover station, enter:

```
interfacemode port rx_type tx_type
```

For example:

```

RTCA      interfacemode com2 rtca none
RTCM      interfacemode com2 rtcm none
RTCMV3    interfacemode com2 rtcmv3 none
CMR       interfacemode com2 cmr none

```

For compatibility with other GPS receivers, and to minimize message size, it is recommended that you use the standard form of RTCA, RTCM or CMR corrections as shown in the examples above. This requires using the INTERFACEMODE command, refer to *Volume 2* of this manual set, to dedicate one direction of a serial port to only that message type. Once the INTERFACEMODE command is used to change the mode from the default, NOVATEL, you can no longer use NovAtel format messages.

If you wish to mix NovAtel format messages and RTCA, RTCM or CMR messages on the same port, you can leave the INTERFACEMODE set to NOVATEL and log out variants of the standard messages with a NovAtel header. ASCII or binary variants can be requested by simply appending an "A" or "B" to the standard message name. For example on the base station:

```

interfacemode com2 novatel novatel

fix position 51.11358042 -114.04358013 1059.4105

log com2 rtcm1b ontime 2

```

At the rover station you can leave the INTERFACEMODE default settings (interfacemode com2

novatel novatel). The rover receiver will recognize the default and use the corrections it receives with a NovAtel header.

The PSRDIFFSOURCE and RTKSOURCE commands set the station ID values which identify the base stations from which to accept pseudorange or RTK corrections respectively. They are useful commands when the rover station is receiving corrections from multiple base stations. With the PSRDIFFSOURCE command, all types may revert to SBAS if enabled using the SBASCONTROL command. Refer to *Volume 2* of this manual set for more details on these commands. See *Section 6.2, Satellite-Based Augmentation System (SBAS) on Page 67* for more information on SBAS.

At the base station it is also possible to log out the contents of the standard corrections in a form that is easier to read or process. These larger variants have the correction fields broken out into standard types within the log, rather than compressed into bit fields. This can be useful if you wish to modify the format of the corrections for a non-standard application, or if you wish to look at the corrections for system debugging purposes. These variants have "DATA" as part of their names (for example, RTCADATA1, RTCMDATA1, CMRDATAOBS, and more). Refer to *Volume 2* of this manual set for details.

Chapter 5, Message Formats on Page 52 describes the various message formats in more detail.

4.4 Enabling SBAS Positioning

OEM4 family receivers with a W, WAAS, MSAS or EGNOS in their model name are capable of SBAS positioning. This positioning mode is enabled using the SBASCONTROL command. EGNOS at one time used the IGNOREZERO test mode. At the time of printing, ZEROTOTWO is the correct setting for all SBAS, including EGNOS, running in test mode. On a simulator, you may want to leave this parameter off or specify NONE explicitly. As a result, the following commands are typically used to enable WAAS and EGNOS modes, respectively:

```
SBASCONTROL WAAS ENABLE 0 ZEROTOTWO
SBASCONTROL EGNOS ENABLE 120 ZEROTOTWO
```

See *Section 6.2, Satellite-Based Augmentation System (SBAS) on Page 67* for more information.

4.5 Enabling L-Band Positioning (ProPak-LBplus Only)

L-Band equipped receivers allow you to achieve sub-meter accuracy. In order to use this positioning mode, you must enable L-band tracking to the Canada-Wide Differential Global Positioning System (CDGPS) or OmniSTAR signal. A subscription to OmniSTAR is required to use the OmniSTAR service. The CDGPS signal is free and available without subscription.

To obtain an OmniSTAR subscription, contact them at 1-800-338-9178 or 713-785-5850. If you contact OmniSTAR, you will be asked to provide the receiver's OmniSTAR serial number (which is different from the NovAtel serial number). To obtain the OmniSTAR serial number, enter the following command in a terminal window or the Console window in GPSolution:

```
LOG LBANDINFO
```

The log that is generated will display the L-Band serial number in the fifth field following the log header. It is a six digit number in the range 700000 to 799999. This log also provides the status of your subscription. Refer to *Volume 2* of this manual set for more information.

In order to activate an OmniSTAR subscription, the receiver must be powered and tracking an L-Band satellite. When advised by OmniSTAR of the appropriate satellite frequency and data link rate for your location, use the ASSIGNLBAND command to configure your receiver. The CDGPS frequencies are on *Page 75* and these can also be used with the ASSIGNLBAND command. As an example, if your frequency is 1,525,000 kHz and your data link speed is 1200 baud, enter the following:

```
ASSIGNLBAND USER 1525000 1200
```

To confirm you are tracking an L-Band signal, log the L-Band status information by entering the following command:

```
LOG LBANDSTAT
```

For example, if you are receiving CDGPS, the fifth field after the header should be 00c2:

```
LBANDSTAT COM1 0 43.5 FINESTEERING 1295 149951.671 00000000
976f 34461
<1547546977 46.18 4541.0 0.00 00c2 00f0 0 0 0 8070 0001 0 0 0
```

Please refer to *Volume 2* of this manual set for more details.

4.6 Pass-Through Logging

The pass-through logging feature enables the receiver to redirect any ASCII or binary data that is input at a specified COM port or, if available, USB port to any specified receiver COM or USB port. This capability, in conjunction with the SEND command, can allow the receiver to perform bi-directional communications with other devices such as a modem, terminal, or another receiver.

There are several pass-through logs **PASSCOM1**, **PASSCOM2**, **PASSCOM3**, **PASSXCOM1**, **PASSXCOM2** and **PASSAUX**, available on OEM4 family receivers for logging through serial ports. The AUX port is available on OEM4-G2-based products (hardware Rev. 3 and higher) and DL-4 products. For the OEM4-G2 and OEM4-G2L, there are an additional three, **PASSUSB1**, **PASSUSB2**, and **PASSUSB3**, offered. Refer to *Volume 2* of this manual set for individual logs and commands.

A pass-through log is initiated the same as any other log, that is, LOG [to-port] [data-type] [trigger]. However, pass-through can be more clearly specified as: LOG [to-port] [from-port-AB] [onchanged]. Now, the [from-port-AB] field designates the port which accepts data (that is, COM1, COM2, COM3, AUX, USB1, USB2, or USB3) as well as the format in which the data will be logged by the [to-port] (A for ASCII or B for Binary).

When the [from-port-AB] field is suffixed with an [A], all data received by that port will be redirected to the [to-port] in **ASCII** format and will log according to standard NovAtel ASCII format. Therefore, all incoming ASCII data will be redirected and output as ASCII data. However, any binary data received will be converted to a form of ASCII hexadecimal before it is logged.

When the [from-port-AB] field is suffixed with a [B], all data received by that port will be redirected to the [to-port] exactly as it is received. The log header and time-tag adhere to standard NovAtel Binary format followed by the pass-through data as it was received (ASCII or binary).

Pass-through logs are best utilized by setting the [trigger] field as **onchanged** or **onnew**. If the data being injected is ASCII then the data will be grouped together with the following rules:

- blocks of 80 characters
- any block of characters ending in a <CR>
- any block of characters ending in a <LF>

- any block remaining in the receiver code when a timeout occurs

If the data being injected is binary then the data will be grouped as follows:

- blocks of 80 bytes
- any block remaining in the receiver code when a timeout occurs

If a binary value is encountered in an ASCII output, then the byte is output as a hexadecimal byte preceded by a backslash and an x. For example 0A is output as \x0A. An actual ‘\’ in the data is output as \\ . The output counts as one pass-through byte although it is four characters.

The first character of each pass-through record is time tagged in GPS weeks and seconds.

For example, you could connect two OEM4 family receivers together via their COM1 ports such as in *Figure 12 on Page 49*, a rover station to base station scenario. If the rover station were logging BESTPOSA data to the base station, it would be possible to use the pass-through logs to pass through the received BESTPOSA data to a disk file (let’s call it DISKFILE.log) at the base station host PC hard disk.

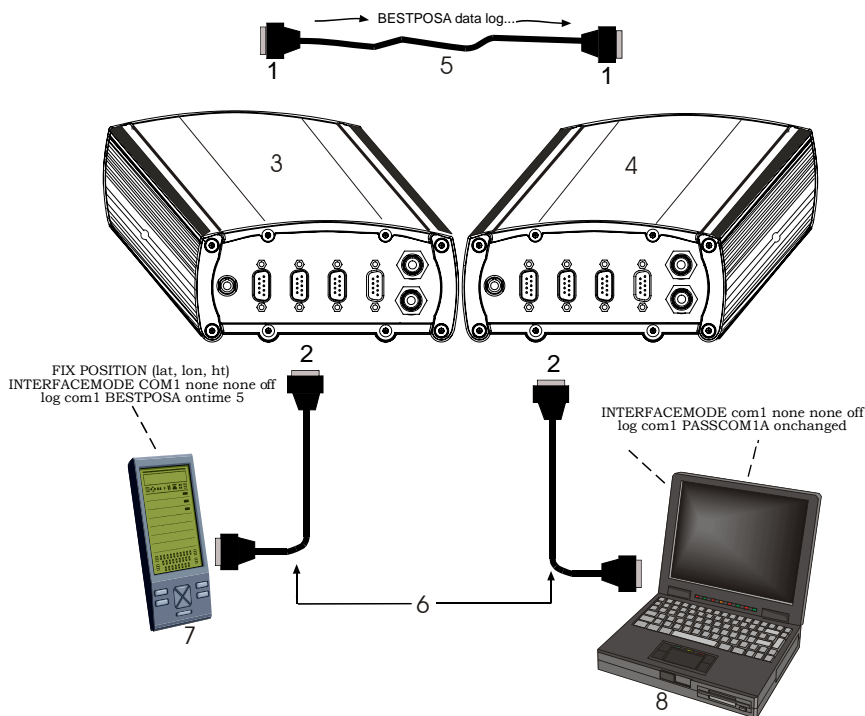

Reference	Description	Reference	Description
1	To COM1	5	Data link
2	To COM2	6	Serial cables
3	Rover receiver	7	Pocket PC - rover
4	Base receiver	8	Laptop PC - base

Figure 12: Pass-Through Log Data

Under default conditions the two receivers will "chatter" back and forth with the **Invalid Command Option** message (due to the command interpreter in each receiver not recognizing the command prompts of the other receiver). This *chattering* will in turn cause the accepting receiver to transmit new pass-through logs with the response data from the other receiver. To avoid this chattering problem, use the INTERFACEMODE command on the accepting port to disable error reporting from the receiving port command interpreter.

If the accepting port's error reporting is disabled by INTERFACEMODE, the BESTPOSA data record would pass through creating two records.

The reason that two records are logged from the accepting receiver is because the first record was initiated by receipt of the BESTPOSA log's first terminator <CR>. Then the second record followed in response to the BESTPOSA log's second terminator <LF>.

Note that the time interval between the first character received and the terminating <LF> can be calculated by differencing the two GPS time tags. This pass-through feature is useful for time tagging the arrival of external messages. These messages could be any user-related data. If the user is using this feature for tagging external events, it is recommended that the command interpreter be disabled so that the receiver does not respond to the messages. Refer to the INTERFACEMODE command in *Volume 2* of this manual set.

If the BESTPOSB **binary** log data were input to the accepting port (log com2 passcom1a unchanged), the BESTPOSB binary data at the accepting port is converted to a variation of ASCII hexadecimal before it is passed through to COM2 port for logging.

4.7 Transferring Time Between Receivers

The following are clock steering states:

- | | |
|------------|--|
| Fine | An OEM4 family receiver that is tracking satellites, and has a receiver clock state of FINE or FINESTEERING. |
| Cold Clock | An OEM4 family receiver that needs to have its clock synchronized with the Fine receiver. It may have any clock state including UNKNOWN. |
| Warm Clock | An OEM4 family receiver that has its clock adjusted to better than 500 ms. Refer to the TIME log in <i>Volume 2</i> of this manual set to view the clock offset. |

The sections that follow are procedures for transferring time from a Fine receiver to a Cold or Warm Clock receiver.

4.7.1 Procedures

To transfer COARSE time (<10 ms) from a Fine to a Cold Clock GPS receiver:

1. Connect a COM port from the Fine to the Cold Clock (for example, COM2 on the Fine to COM3 on the Cold Clock). Configure both ports to the same baud rate and handshaking configurations.
2. Issue this command to the Fine receiver:

```
log com2 timesyncb ontime 1
```
3. Issue this command to the Cold Clock receiver: `adjust1pps time`

When the Cold Clock receiver receives the TIMESYNC log, it sets its clock allowing for a 100 ms transfer delay.

To transfer FINE time (<50 ns) from a Fine GPS to a Cold Clock GPS receiver:

1. Connect a COM port from the Fine to the Cold Clock receiver (for example, COM2 on the Fine to COM3 on the Cold Clock). Configure both ports to the same baud rate and handshaking configurations.
2. Issue this command to the Fine receiver:
`log com2 timesyncb ontime 1`
3. Connect the 1PPS signal of the Fine to the mark 1 input (Event1) of the Cold Clock receiver.
4. Issue this command to the Cold Clock receiver:
`adjust1pps markwithtime`

When the Cold Clock receiver receives the 1PPS "event" from the Fine receiver, it checks to see if it has received a valid TIMESYNC log within 200 ms of the last 1PPS event. If so, it will set the Cold Clock receiver clock to the time of the Fine receiver. See *Figure 13, 1PPS Alignment* below.

To transfer FINE time from a Fine to a Warm Clock GPS receiver:

1. Connect the 1PPS signal of the Fine to the mark 1 input (Event1) of the Warm Clock receiver.
2. Issue this command to the Warm Clock receiver:
`adjust1pps mark`

The phase of the Warm Clock receiver clock is adjusted by the fractional measurement of the Fine receiver's 1PPS mark input event. In other words, it will synchronize the Warm Clock receiver's 1PPS to the incoming 1PPS of the Fine receiver. It will NOT adjust the 1 second Time of Week (TOW) counter or the receiver's Week Number. This procedure is used to make small corrections to the Warm Clock receiver's clock.

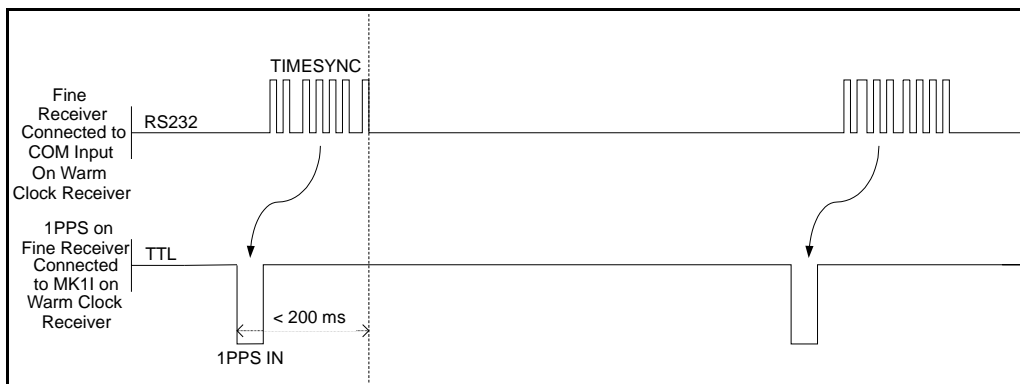

Figure 13: 1PPS Alignment

The chapter discusses the various industry-standard message formats that can be used with your NovAtel OEM4 family receiver, including RTCA, RTCM, RTCMV3, CMR, and NMEA. See *Section 4.3, Transmitting and Receiving Corrections on Page 45* for more information on using these message formats for differential operation.

5.1 RTCA-Format Messages

The RTCA (Radio Technical Commission for Aviation Services) Standard is being designed to support Differential Global Navigation Satellite System (DGNSS) Special Category I (SCAT-I) precision instrument approaches. The RTCA Standard is in a preliminary state. Described below is NovAtel's current support for this standard. It is based on "Minimum Aviation System Performance Standards DGNSS Instrument Approach System: Special Category I (SCAT-I)" dated August 27, 1993 (RTCA/DO-217).

NovAtel has defined three proprietary RTCA Standard Type 7¹ binary-format messages, RTCAOBS, RTCAREF and RTCAEPHEM for base station transmissions. These can be used with either single or dual-frequency NovAtel receivers. The RTCA message format outperforms the RTCM format in the following ways, among others:

- a more efficient data structure (lower overhead)
- better error detection
- allowance for a longer message, if necessary

RTCAREF and RTCAOBS, respectively, correspond to the RTCM Type 3 and Type 59 logs used in single-frequency-only measurements. Both are NovAtel-proprietary RTCA Standard Type 7 messages with an 'N' primary sub-label.

See *Section 4.3, Transmitting and Receiving Corrections on Page 45* for more information on using these message formats for differential operation.

5.1.1 RTCA1

This log enables transmission of RTCA Standard format Type 1 messages from the receiver when operating as a base station. Before this message can be transmitted, the receiver FIX POSITION command must be set. The RTCA log will be accepted by a receiver operating as a rover station over a COM port after an INTERFACEMODE *port* RTCA_INTERFACE command is issued.

The RTCA Standard for SCAT-I stipulates that the maximum age of differential correction (Type 1) messages accepted by the rover station cannot be greater than 22 seconds. Refer to the DGPSTIMEOUT command in *Volume 2* of this manual set for information regarding DGPS delay settings.

1. For further information on RTCA Standard messages, you may wish to refer to:

Minimum Aviation System Performance Standards - DGNSS Instrument Approach System: Special Category I (SCAT-I), Document No. RTCA/DO-217 (April 19, 1995); Appendix A, Page 21.

The RTCA Standard also stipulates that a base station shall wait five minutes after receiving a new ephemeris before transmitting differential corrections. Refer to the DGPSEPHMDELAY command in *Volume 2* of this manual set for information regarding ephemeris delay settings.

The basic SCAT-I Type 1 differential correction message is as follows:

Format: Message length = 11 + (6*obs): (83 bytes maximum)

Field Type	Data	Scaling	Bits	Bytes
SCAT-I header	– Message block identifier	-	8	6
	– Base station ID	-	24	
	– Message type (this field will always report 00000100)	-	8	
	– Message length	-	8	
Type 1 header	– Modified z-count	0.2 s	13	2
	– Acceleration error bound (In the receiver, this field will report 000)	-	3	
Type 1 data	– Satellite ID	-	6	6 * obs
	– Pseudorange correction ^a	0.02 m	16	
	– Issue of data	-	8	
	– Range rate correction ^a	0.002 m/s	12	
	– UDRE	0.2 m	6	
CRC	Cyclic redundancy check	-		3

a. The pseudorange correction and range rate correction fields have a range of ±655.34 meters and ±4.049 m/s respectively. Any satellite which exceeds these limits will not be included.

5.1.2 RTCAEPHEM Type 7

An RTCAEPHEM (RTCA Satellite Ephemeris Information) message contains raw satellite ephemeris information. It can be used to provide a rover receiver with a set of GPS ephemerides. Each message contains a complete ephemeris for one satellite and the GPS time of transmission from the base. The message is 102 bytes (816 bits) long. This message should be sent once every 5-10 seconds (The faster this message is sent, the quicker the rover station will receive a complete set of ephemerides). Also, the rover receiver will automatically set an approximate system time from this message if time is still unknown. Therefore, this message can be used in conjunction with an approximate position to improve time to first fix (TTFF). Refer also to the *GPS+ Reference Manual*.

5.1.3 RTCAOBS Type 7

An RTCAOBS (RTCA Base-Station Satellite Observations) message contains base station satellite observation information. It is used to provide range observations to the rover receiver, and should be sent every 1 or 2 seconds. This log is made up of variable-length messages up to 255 bytes long. The maximum number of bits in this message is [140 + (92 x N)], where N is the maximum number of satellite record entries transmitted. Using the RTKSVENTRIES command, you can define N to be anywhere from 4 to 12; the default value is 12.

5.1.4 RTCAREF Type 7

An RTCAREF (RTCA Base Station Position Information) message contains base station position information, and should be sent once every 10 seconds. Each message is 24 bytes (192 bits) long.

If RTCA-format messaging is being used, the optional *station id* field that is entered using the DGPSTXID command can be any 4-character string combining numbers and upper-case letters, and enclosed in double quotation marks (for example, "RW34"). The station ID will be reported at the rover receiver, in its position log.

Also, the rover receiver will automatically set an approximate position from this message if it does not already have a position. Therefore this message can be used in conjunction with an approximate time to improve TTFF, refer to the *Time to First Fix and Satellite Acquisition* section of the *GPS+ Reference Manual*.

5.2 RTCM-Format Messages

The Radio Technical Commission for Maritime Services (RTCM) was established to facilitate the establishment of various radio navigation standards, which includes recommended GPS differential standard formats. See *Section 4.3, Transmitting and Receiving Corrections on Page 45* for more information on using these message formats for differential operation.

The standards recommended by the Radio Technical Commission for Maritime Services Special Committee 104, Differential GPS Service (RTCM SC-104, Washington, D.C.), have been adopted by NovAtel for implementation into the receiver. Because the receiver is capable of utilizing RTCM formats, it can easily be integrated into positioning systems around the globe.

As it is beyond the scope of this manual to provide in-depth descriptions of the RTCM data formats, it is recommended that anyone requiring explicit descriptions of such, should obtain a copy of the published RTCM specifications. Refer to the *Standards/References* section of the *GPS+ Reference Manual* for reference information.

RTCM SC-104¹ Type 3 & 59 messages can be used for base station transmissions in differential systems. However, since these messages do not include information on the L2 component of the GPS signal, they cannot be used with RT-2 positioning. Regardless of whether single or dual-frequency receivers are used, the RT-20 positioning algorithm would be used. This is for a system in which both the base and rover stations utilize NovAtel receivers.

Note that the error-detection capability of an RTCM-format message is less than that of an RTCA-format message. The communications equipment that you use may have an error-detection capability of its own to supplement that of the RTCM message, although at a penalty of a higher overhead. Consult the vendor's documentation for further information.

1. For further information on RTCM SC-104 messages, you may wish to refer to:

RTCM Recommended Standards for Differential GNSS (Global Navigation Satellite Systems) Service, Version 2.3

If RTCM-format messaging is being used, the optional *station id* field that is entered using the FIX POSITION command can be any number within the range of 0 - 1023 (for example, 119). The representation in the log message would be identical to what was entered.

The NovAtel logs which implement the RTCM Standard Format for Type 1, 3, 9, 16, 18, 19 and 22 messages are known as the RTCM1, RTCM3, RTCM9, RTCM16, RTCM18, RTCM19 and RTCM22 logs, respectively, while Type 59N-0 messages are listed in the RTCM59 log.

All receiver RTCM standard format logs adhere to the structure recommended by RTCM SC-104. Thus, all RTCM message are composed of 30 bit words. Each word contains 24 data bits and 6 parity bits. All RTCM messages contain a 2-word header followed by 0 to 31 data words for a maximum of 33 words (990 bits) per message.

Message Frame Header	Data	Bits
Word 1	– Message frame preamble for synchronization	8
	– Frame/message type ID	6
	– Base station ID	10
	– Parity	6
Word 2	– Modified z-count (time tag)	13
	– Sequence number	3
	– Length of message frame	5
	– Base health	3
	– Parity	6

The remainder of this section will provide further information concerning receiver commands and logs that utilize the RTCM data formats.

5.2.1 RTCM1

This is the primary RTCM log used for pseudorange differential corrections. This log follows the RTCM Standard Format for a Type 1 message. It contains the pseudorange differential correction data computed by the base station generating this Type 1 log. The log is of variable length, depending on the number of satellites visible and pseudoranges corrected by the base station. Satellite specific data begins at word 3 of the message.

Structure:

(Follows the RTCM Standard for a Type 1 message)

Type 1 messages contain the following information for each satellite in view at the base station:

- Satellite ID
- Pseudorange correction
- Range-rate correction
- Issue of Data (IOD)

When operating as a base station, the receiver must be in FIX POSITION mode and have the INTERFACEMODE command set before the data can be correctly logged, see *Transmitting and Receiving Corrections on Page 45*.

When operating as a rover station, the receiver COM port receiving the RTCM data must have its INTERFACEMODE command set, see *Transmitting and Receiving Corrections on Page 45*.

REMEMBER: Upon a change in ephemeris, base stations will transmit Type 1 messages based on the old ephemeris for a period of time defined by the DGPSEPHMDELAY command. After the timeout, the base station will begin to transmit the Type 1 messages based on new ephemeris.

5.2.2 RTCM3 Base Station Parameters (RTK)

This log contains the GPS position of the base station expressed in rectangular ECEF coordinates based on the center of the WGS-84 ellipsoid. This log uses four RTCM data words following the two-word header, for a total frame length of six 30 bit words (180 bits maximum). This message must be sent at least once every 30 seconds, although it is recommended that it be sent once every 10 seconds.

Also, the rover receiver will automatically set an approximate position from this message if it does not already have a position. Therefore this message can be used in conjunction with an approximate time to improve TTFF, refer to the *Time to First Fix and Satellite Acquisition* section of the *GPS+ Reference Manual*.

Structure:

(Follows the RTCM SC-104 Standard for a Type 3 message)

Type 3 messages contain the following information:

- Scale factor
- ECEF X-coordinate
- ECEF Y-coordinate
- ECEF Z-coordinate

The receiver only transmits the RTCM Type 3 when the position is fixed by the FIX POSITION command.

This log is intended for use when operating in RT-20 or RT-2 mode.

5.2.3 RTCM9 Partial Satellite Set Differential Corrections

RTCM Type 9 messages follow the same format as Type 1 messages. However, unlike a Type 1 message, Type 9 does not require a complete satellite set. This allows for much faster differential correction data updates to the rover stations, thus improving performance and reducing latency.

Type 9 messages should give better performance with slow or noisy data links.

-
- ☒ The base station transmitting the Type 9 corrections must be operating with a high-stability clock to prevent degradation of navigation accuracy due to the unmodeled clock drift that can occur between Type 9 messages. For this reason, only OEM4-G2 receivers with an external oscillator can generate Type 9 messages. All OEM4 family receivers can accept Type 9 messages.

NovAtel recommends a high-stability clock such as the PIEZO Model 2900082 whose 2-sample (Allan) variance meets the following stability requirements:

$$3.24 \times 10^{-24} \text{ s}^2/\text{s}^2 \text{ between } 0.5 - 2.0 \text{ seconds, and}$$

$$1.69 \times 10^{-22} \text{ T s}^2/\text{s}^2 \text{ between } 2.0 - 100.0 \text{ seconds}$$

An external clock, such as an OCXO, requires approximately 10 minutes to warm up and become fully stabilized after power is applied; do not broadcast RTCM Type 9 corrections during this warm-up period.

Structure:

(Follows the RTCM Standard SC-104 for a Type 1 message)

Type 9 messages contain the following information for a group of three satellites in view at the base station:

- Scale factor
- User Differential Range Error
- Satellite ID
- Pseudorange correction
- Range-rate correction
- Issue of Data (IOD)

5.2.4 RTCM15 Ionospheric Corrections

RTCM Type 15 messages are designed to support the broadcast of ionospheric delay and rate of change measurements for each satellite as determined by the base station receiver. This message is used to improve the ionospheric de-correlation that would otherwise be experienced by a rover at a long distance from the base station. This log is designed to work in conjunction with Type 1 messages using dual frequency receivers. It is anticipated Type 15 messages will be broadcast every 5-10 minutes.

Type 15 messages are designed to enable the rover to continuously remove the ionospheric component from received pseudorange corrections. The delay and rate terms are added exactly like Type 1 corrections to provide the total ionospheric delay at a given time, and the total ionospheric delay is then subtracted from the pseudorange corrections. The resulting corrections are then "iono-free". The rover subtracts its measurements (or estimates) of ionospheric delay from its own pseudorange measurements and applies the iono-free corrections.

Structure:

(Follows RTCM standard for Type 15 message)

Type 15 messages contain the following information for each satellite in view at the base station:

- Satellite ID
- Ionospheric delay
- Iono rate of change

When operating as a base station, the receiver must be in FIX POSITION mode and have the INTERFACEMODE command set before the data can be correctly logged. You must also be logging the RTCM Type 1 corrections.

When operating as a rover station, the receiver COM port receiving the RTCM data must have its INTERFACEMODE command set.

5.2.5 **RTCM16 Special Message**

This log contains a special ASCII message that can be displayed on a printer or cathode ray tube. The base station wishing to log this message out to rover stations that are logged onto a computer, must use the SETRTCM16T command to set the required ASCII text message. Once set, the message can then be issued at the required intervals with the “LOG port RTCM16 interval” command. The Special Message setting can be verified in the RXCONFIGA log. The received ASCII text can be displayed at the rover by logging RTCM16T ONNEW.

The RTCM16 data log follows the RTCM Standard Format. Words 1 and 2 contain RTCM header information followed by words 3 to n (where n is variable from 3 to 32) which contain the special message ASCII text. Up to 90 ASCII characters can be sent with each RTCM Type 16 message frame.

Structure:

(Follows the RTCM Standard SC-104 for a Type 16 message)

5.2.6 **RTCM18 and RTCM19 Raw Measurements (RTK)**

RTCM18 provides uncorrected carrier phase measurements and RTCM19 provides uncorrected pseudorange measurements. The measurements are not corrected by the ephemerides contained in the satellite message.

The messages have similar formats. Word 3, the first data word after the header, contains a GPS TIME OF MEASUREMENT field which is used to increase the resolution of the MODIFIED Z-COUNT in the header. Word 3 is followed by pairs of words containing the data for each satellite observed. Appropriate flags are provided to indicate L1 C/A or P-code or L2 cross correlated or P-code measurements. The carrier smoothing interval for pseudoranges and pseudorange corrections is also furnished, for a total frame length of six 30 bit words (180 bits maximum).

Structure:

(Follows the RTCM SC-104 Standard for a Type 18 and Type 19 message)

For RT-20 or RT-2, you may periodically transmit a set of RTCM Type 18 and RTCM Type 19 together with an RTCM Type 3 message and an RTCM Type 22 message.

5.2.7 **RTCM20 and RTCM21 Measurement Corrections (RTK)**

RTCM20 provides carrier phase corrections and RTCM21 provides pseudorange corrections. Types 20 and 21 are corrected by the ephemerides contained in the satellite message and are therefore referred to as ‘corrections’.

Message Type 21 is very similar to the standard Type 1 message, but has additional measurement quality information, and can be used to support cross-correlation receivers. Message Type 21 is also useful in non-kinematic applications requiring high accuracy and integrity.

See *Section 5.2.6* above for the message format of the Type 18 and 19 messages that are similar to the Type 20 and 21 messages.

5.2.8 **RTCM22 RTCM Extended Base Station Parameters (RTK)**

Message Type 22 provides firstly, a means of achieving sub-millimeter precision for base station coordinates, and secondly, base station antenna height above a base, which enables mobile units to reference measured position to the base directly in real time.

The first data word of message Type 22 provides the corrections to be added to each ECEF coordinate. Note that the corrections may be positive or negative.

The second data word, which may not be transmitted, provides the antenna L1 phase center height expressed in integer and fractional centimeters, and is always positive. It has the same resolutions as the corrections. The range is about 10 meters. The spare bits can be used if more height range is required.

5.2.9 **RTCM59 Type 59N-0 NovAtel Proprietary Message (RTK)**

RTCM Type 59 messages are reserved for proprietary use by RTCM base station operators.

Each message is variable in length, limited only by the RTCM maximum of 990 data bits (33 words maximum). The first eight bits in the third word (the word immediately following the header) serve as the message identification code, in the event that the base station operator wishes to have multiple Type 59 messages.

NovAtel has defined only a Type 59N-0 message to date; it is to be used for operation in receivers capable of operating in RT-20 Carrier Phase Differential Positioning Mode. This log is primarily used by a base station to broadcast its RT-20 observation data (delta pseudorange and accumulated Doppler range) to rover RT-20 – capable receivers. Type 59N messages should be sent once every 2 seconds.

-
- ☒ 1. The COMSTATSA/B log is very useful for monitoring the serial data link, as well as differential data decode success.
 - 2. This log is intended for use when operating in RT-20 mode.
-

5.3 RTCM Version 3.0 (RTCMV3) Messaging

RTCM SC-104 is a more efficient alternative to the documents entitled "RTCM Recommended Standards for Differential Navstar GPS Service, Version 2.x". Version 3.0, consists primarily of messages designed to support real-time kinematic (RTK) operations. The reason for this emphasis is that RTK operation involves broadcasting a lot of information, and thus benefits the most from a more efficient data format.

The RTCM SC-104 standards have been adopted by NovAtel for implementation into the receiver. The receiver can easily be integrated into positioning systems around the globe because it is capable of utilizing RTCM Version 3.0 formats.

The initial Version 3.0 document describes messages and techniques for supporting GPS. However, the format accommodates modifications to these systems (for example, new signals), and to new satellite systems that are under development. In addition, augmentation systems that utilize geostationary satellites with transponders operating in the same frequency bands are now in the implementation stages. Generically they are called Satellite-Based Augmentation Systems (SBAS), and they have been designed to be interoperable (for example WAAS, EGNOS, MSAS).

Message types contained in the current Version 3.0 standard have been structured in different groups. Transmit at least one message type from each of the following groups:

Group 1 - Observations:	RTCM1001	L1-Only GPS RTK
	RTCM1002	Extended L1-Only GPS RTK
	RTCM1003	L1 And L2 GPS RTK
	RTCM1004	Extended L1 and L2 GPS RTK
Group 2 - Base Station Coordinates:	RTCM1005	RTK Base Antenna Reference Point (ARP)
	RTCM1006	RTK Base ARP with Antenna Height

5.3.1 RTCM1001-RTCM1004 GPS RTK Observables

RTCM1001, RTCM1002, RTCM1003 and RTCM1004 are GPS real-time kinematic (RTK) messages, which are based on raw data. From these data, valid RINEX files can be obtained. As a result, this set of messages offers a high level of interoperability and compatibility with standard surveying practices. See also *Table 18* on *Page 94* for details on the logs that Convert4 converts to RINEX.

The Type 1001 Message supports single-frequency RTK operation. It does not include an indication of the satellite carrier-to-noise ratio as measured by the reference station.

The Type 1002 Message supports single-frequency RTK operation, and includes an indication of the satellite carrier-to-noise (CNR) as measured by the reference station. Since the CNR does not usually change from measurement to measurement, this message type can be mixed with the Type 1001, and used primarily when a satellite CNR changes, thus saving broadcast link throughput.

The Type 1003 Message supports dual-frequency RTK operation, but does not include an indication of the satellite carrier-to-noise (CNR) as measured by the reference station.

The Type 1004 Message supports dual-frequency RTK operation, and includes an indication of the satellite carrier-to-noise (CNR) as measured by the reference station. Since the CNR does not usually change from measurement to measurement, this message type can be mixed with the Type 1003, and used only when a satellite CNR changes, thus saving broadcast link throughput.

Message Type 1001 contains the shortest version of a message for GPS observations, namely L1-only observables. Message Type 1002 contains additional information that enhances performance. If throughput is not limited and the additional information is available, it is recommended to use the longer version of messages. Similarly, Message Type 1003 provides minimum data for L1/L2 operation, while Message Type 1004 provides the full data content. The longer observation messages do not change very often, and can be sent less often.

5.3.2 RTCM1005 & RTCM1006 RTK Base Antenna Reference Point (ARP)

Message Type 1005 provides the earth-centered, earth-fixed (ECEF) coordinates of the antenna reference point (ARP) for a stationary reference station. No antenna height is provided.

Message Type 1006 provides all the same information as Message Type 1005, but additionally provides the height of the ARP.

These messages are designed for GPS operation, but are equally applicable to future satellite systems, and system identification bits are reserved for them.

Message Types 1005 and 1006 avoid any phase center problems by utilizing the ARP, which is used throughout the International GPS Service (IGS). They contain the coordinates of the installed antenna's ARP in Earth-Center-Earth-Fixed (ECEF) coordinates - datum definitions are not yet supported. The coordinates always refer to a physical point on the antenna, typically the bottom of the antenna mounting surface.

5.4 CMR Format Messaging

The Compact Measurement Record (CMR) message format was developed by Trimble Navigation Ltd. as a proprietary data transmission standard for use in RTK applications. In 1996 Trimble publicly disclosed this standard and allowed its use by all manufacturers in the GPS industry¹.

The NovAtel implementation allows a NovAtel rover receiver to operate in either RT-2 or RT-20 mode while receiving pseudorange and carrier phase data via CMR messages (version 3.0) from a non-NovAtel base-station receiver. The NovAtel receiver can also transmit CMR messages (version 3.0). The station ID must be ≤ 31 when transmitting CMR corrections, refer to *Volume 2, Chapter 2* of this manual set. The CMRPLUS output message distributes the reference station information over 14 updates. Refer to the CMRPLUS log in *Volume 2, Chapter 3* of this manual set for more details.

The message lengths of the three CMR messages are as follows:

CMROBS = 6 (frame) + 6 (header) + (8*L1 channels) + (7*L2 channels): (192 bytes maximum)

CMRREF = 6 (frame) + 6 (header) + 19: (31 bytes)

CMRDESC = 6 (frame) + 6 (header) + (variable: 26 to 75): (38 bytes minimum; 87 bytes maximum)

No guarantee is made that the OEM4 will meet its performance specifications if non-NovAtel equipment is used.

Trimble rovers must receive CMRDESC messages from a base.

1. Talbot, N.C. (1996), "Compact Data Transmission Standard for High-Precision GPS". Proceeding of the ION GPS-96 Conference, Kansas City, MO, September 1996, Vol. I, pp. 861-871

See *Section 4.3, Transmitting and Receiving Corrections on Page 45* for more information on using these message formats for differential operation.

5.4.1 Using RT-2 or RT-20 with CMR Format Messages

To enable receiving CMR messages, follow these steps:

1. Issue the COM command to the rover receiver to set its serial port parameters to the proper bit rate, parity, and so on. This command is described in detail in *Volume 2* of this manual set.
2. Issue the “INTERFACEMODE COMn CMR” command to the rover receiver, where “COMn” refers to the communication port that is connected to the data link. This command is described in detail in the *OEM4 Family User Manual - Volume 2* of this manual set.

Assuming that the base station is transmitting valid data, your rover receiver will now begin to operate in RT-2 or RT-20 mode. To send CMR messages, do the following:

Periodically transmit three CMR messages at the base station:

- A CMROBS message contains base station satellite observation information, and should be sent once every 1 or 2 seconds.
- A CMRREF message contains base station position information, and should be sent once every 10 seconds. Also, the rover receiver will automatically set an approximate position from this message if it does not already have a position. Therefore this message can be used in conjunction with an approximate time to improve TTFF, refer to the *Time to First Fix and Satellite Acquisition* section of the *GPS+ Reference Manual*.
- A CMRDESC message contains base station description information and should be sent once every 10 seconds, however, it should interlinked with the CMRREF message.

Example:

```
log CMROBS ontime 1
log CMRREF ontime 10
log CMRDESC ontime 10 5
```

-
- ☒ 1. For CMR the station ID must be less than 31 (refer to the RTKSOURCE and DGPSTXID commands in *Volume 2* of this manual set).
 - 2. CMRDESC is logged with an offset of 5 to allow interleaving with CMRREF. Note that, Trimble rovers must receive CMRDESC messages from a base.
 - 3. Novatel CMR Type 2 messages are for compatibility only. When received, a type 2 message is discarded. For transmission, all fields are permanently set as follows:

Record Length	=	33 bytes
Short Station ID	=	"cref"
COGO Code	=	""
Long Station ID	=	"UNKNOWN"

5.5 NMEA Format Data Logs

The NMEA log structures follow format standards as adopted by the National Marine Electronics Association. The reference document used is "Standard For Interfacing Marine Electronic Devices NMEA 0183 Version 3.01". For further information, see the appendix on *Standards and References* in the *GPS+ Reference Manual* available on our website at <http://www.novatel.com/Downloads/docupdates.html>. The following table contains excerpts from Table 6 of the NMEA Standard which defines the variables for the NMEA logs. The actual format for each parameter is indicated after its description.

Field Type	Symbol	Definition
Special Format Fields		
Status	A	Single character field: A = Yes, Data Valid, Warning Flag Clear V = No, Data Invalid, Warning Flag Set
Latitude	llll.ll	Fixed/Variable length field: degrees minutes.decimal - 2 fixed digits of degrees, 2 fixed digits of minutes and a <u>variable</u> number of digits for decimal-fraction of minutes. Leading zeros always included for degrees and minutes to maintain fixed length. The decimal point and associated decimal-fraction are optional if full resolution is not required.
Longitude	yyyy.yy	Fixed/Variable length field: degrees minutes.decimal - 3 fixed digits of degrees, 2 fixed digits of minutes and a <u>variable</u> number of digits for decimal-fraction of minutes. Leading zeros always included for degrees and minutes to maintain fixed length. The decimal point and associated decimal-fraction are optional if full resolution is not required
Time	hhmmss.ss	Fixed/Variable length field: hours minutes seconds.decimal - 2 fixed digits of hours, 2 fixed digits of minutes, 2 fixed digits of seconds and <u>variable</u> number of digits for decimal-fraction of seconds. Leading zeros always included for hours, minutes and seconds to maintain fixed length. The decimal point and associated decimal-fraction are optional if full resolution is not required.
Defined field		Some fields are specified to contain pre-defined constants, most often alpha characters. Such a field is indicated in this standard by the presence of one or more valid characters. Excluded from the list of allowable characters are the following which are used to indicate field types within this standard: "A", "a", "c", "hh", "hhmmss.ss", "llll.ll", "x", "yyyy.yy"
Numeric Value Fields		
Variable numbers	x.x	Variable length integer or floating numeric field. Optional leading and trailing zeros. The decimal point and associated decimal-fraction are optional if full resolution is not required (example: 73.10 = 73.1 = 073.1 = 73)
Fixed HEX	hh____	Fixed length HEX numbers only, MSB on the left
Information Fields		
Variable text	c--c	Variable length valid character field.
Fixed alpha	aa____	Fixed length field of uppercase or lowercase alpha characters
Fixed number	xx____	Fixed length field of numeric characters
Fixed text	cc____	Fixed length field of valid characters
NOTES:		
<ol style="list-style-type: none"> 1. Spaces may only be used in variable text fields. 2. A negative sign "-" (HEX 2D) is the first character in a Field if the value is negative. The sign is omitted if value is positive. 3. All data fields are delimited by a comma (,). 4. Null fields are indicated by no data between two commas (,,). Null fields indicate invalid or no data available. 5. The NMEA Standard requires that message lengths be limited to 82 characters. 		

NovAtel's dual frequency GPS receivers have several important performance advantages depending on your positioning requirements. Dual frequency allows direct measurement of the signal delay through the ionosphere and is critical to fast and reliable integer ambiguity resolution when positioning using carrier measurements.

Dual frequency can improve the performance of DGPS, SBAS, and RTK positioning. Using RTCM type 15 messages will allow the DGPS user to apply a local ionospheric correction to their dual frequency receiver to improve code positioning performance on larger baselines (hundreds of km). SBAS positioning is improved by applying a local correction instead of using the SBAS ionospheric grid, and RTK solutions are improved on long baselines by using an ionosphere free solution.

By default the models with L-Band software only support the standard Canada-Wide Differential Global Positioning System (CDGPS) or OmniSTAR Virtual Base Station (VBS) services. The OmniSTAR VBS service is upgradeable to the Extra Performance (XP) L1/L2 decimeter or High Performance (HP) L1/L2 sub-decimeter service via a coded message from an OmniSTAR satellite.

The OEM4 family of receivers operate in the most accurate positioning mode possible with the signals available, and immediately drop to the next positioning mode if the current signal times out.

The following single and dual frequency modes of operation are described further in this chapter:

- Single Point
- Satellite-Based Augmentation System (SBAS)
- Pseudorange Differential
- L-Band
- Carrier-Phase Differential

Refer to the *GPS Overview* section of the *GPS+ Reference Manual* for an overview of GPS positioning.

6.1 Single-Point

The NovAtel OEM4 family receivers are capable of absolute single-point positioning accuracies of 1.8 meters CEP (GDOP < 2; no multipath).

The general level of accuracy available from single-point operation may be suitable for many types of positioning such as ocean going vessels, general aviation, and recreational vessels that do not require position accuracies of better than 1.8 meters CEP. However, increasingly more and more applications desire and require a much higher degree of accuracy and position confidence than is possible with single-point pseudorange positioning. This is where differential GPS (DGPS) plays a dominant role in higher accuracy real-time positioning systems.

By averaging many GPS measurement epochs over several hours, it is possible to achieve a more accurate absolute position. This section attempts to explain how the position averaging function operates and to provide an indication of the level of accuracy that can be expected versus total averaging time.

The POSAVE command implements position averaging for base stations. Position averaging will continue for a specified number of hours or until the averaged position is within specified accuracy limits. Averaging will stop when the time limit or the horizontal standard deviation limit or the vertical standard deviation limit is achieved. When averaging is complete, the FIX POSITION command will automatically be invoked.

If the maximum time is set to 1 hour or larger, positions will be averaged every 10 minutes and the standard deviations reported in the AVEPOS log should be correct. If the maximum time is set to less than 1 hour, positions will be averaged once per minute and the standard deviations reported in the log will likely not be accurate; also, the optional horizontal and vertical standard deviation limits cannot be used.

If the maximum time that positions are to be measured is set to 24, for example, you can then log AVEPOS with the trigger 'onchanged' to see the averaging status:

```
posave 24
log com1 avepos onchanged
```

If desired, you could initiate differential logging, then issue the POSAVE command followed by the SAVECONFIG command. This will cause the receiver to average positions after every power-on or reset, then invoke the FIX POSITION command to enable it to send differential corrections.

The position accuracy that may be achieved by these methods will be dependent on many factors: average satellite geometry, sky visibility at antenna location, satellite health, time of day, and so on. The following graph summarizes the results of several examples of position averaging over different time periods. The intent is to provide an idea of the relationship between averaging time and position accuracy. All experiments were performed using a dual frequency receiver with an ideal antenna location, see *Figure 14, Single-Point Averaging (Typical Results)* below. *Figure 15, Single-Point Averaging (Typical Results with WAAS)* on Page 66 shows the results from the same dual frequency receiver but with WAAS corrections available.

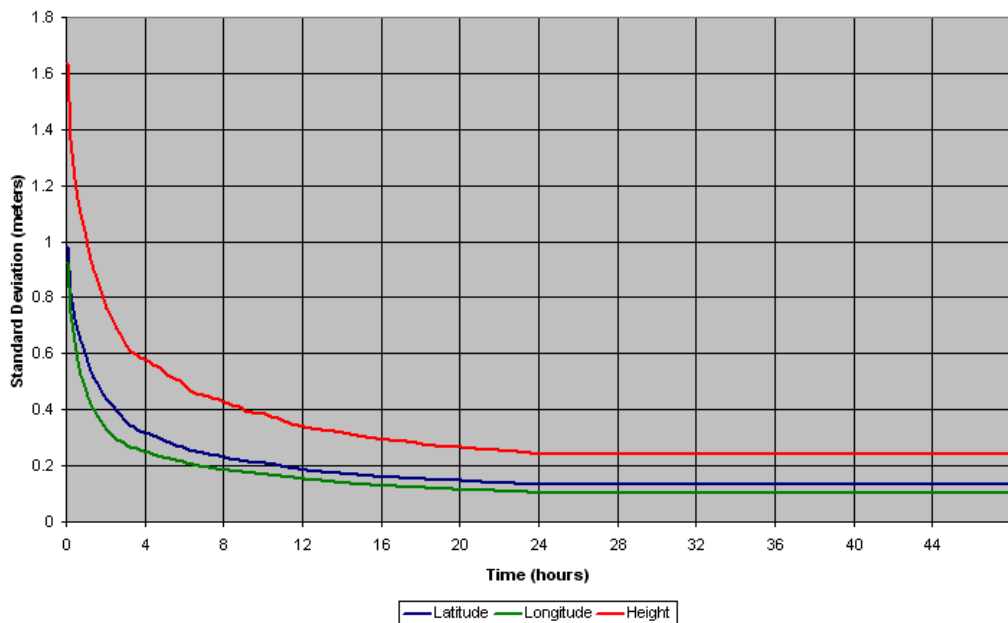

Figure 14: Single-Point Averaging (Typical Results)

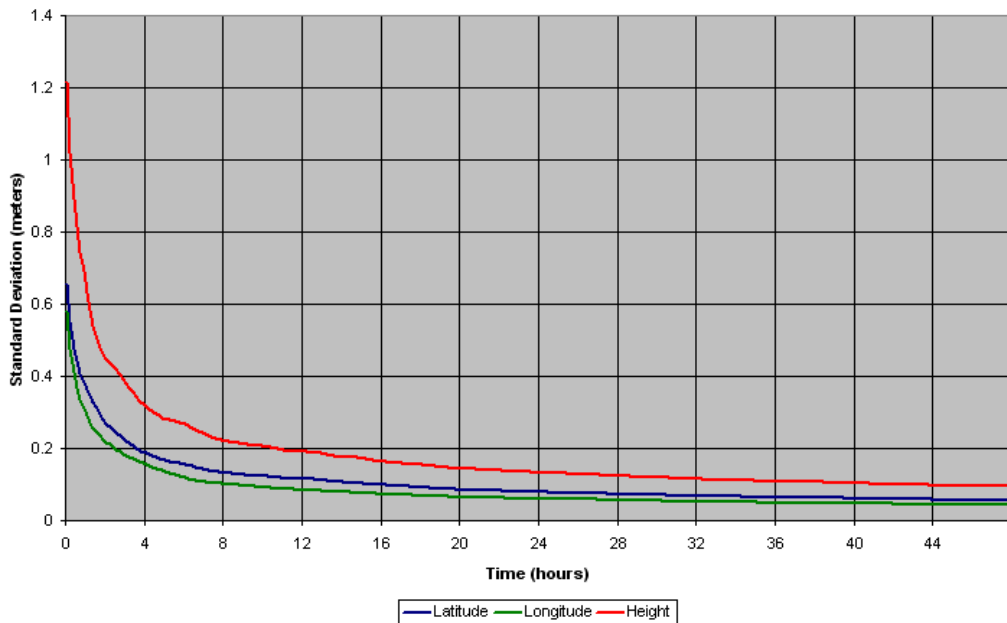

Figure 15: Single-Point Averaging (Typical Results with WAAS)

The position averaging function is useful for obtaining the WGS84 position of a point to a reasonable accuracy without having to implement differential GPS. It is interesting to note that even a six hour occupation can improve single-point GPS accuracy from over 1.5 meters to better than a meter. This improved accuracy is primarily due to the reductions of the multipath errors in the GPS signal.

Again, it is necessary to keep in mind that the resulting standard deviations of the position averaging can vary quite a bit, but improve over longer averaging times. To illustrate, the position averaging function was run for a period of 40 hours. The resulting standard deviation in latitude varied from 0.152 to 1.5589 meters. Similarly, the variation in longitude and height were 0.117 to 0.819 meters and 0.275 to 2.71 meters respectively. This degree of variation becomes larger for averaging periods of less than 12 hours due to changes in the satellite constellation. The graph provides some indication of the accuracy one may expect from single-point position averaging.

The next section deals with the type of GPS system errors that can affect accuracy in single-point operation.

6.1.1 GPS System Errors

In general, GPS SPS C/A code single-point pseudorange positioning systems are capable of absolute position accuracies of about 1.8 meters or less. This level of accuracy is really only an estimation, and may vary widely depending on numerous GPS system biases, environmental conditions, as well as the GPS receiver design and engineering quality.

There are numerous factors which influence the single-point position accuracies of any GPS C/A code receiving system. As the following list will show, a receiver's performance can vary widely when under the influences of these combined system and environmental biases.

- **Ionospheric Group Delays** – The earth’s ionospheric layers cause varying degrees of GPS signal propagation delay. Ionization levels tend to be highest during daylight hours causing propagation delay errors of up to 30 meters, whereas night time levels are much lower and may be as low as 6 meters.
- **Tropospheric Refraction Delays** – The earth’s tropospheric layer causes GPS signal propagation delays. The amount of delay is at the minimum (about three metres) for satellite signals arriving from 90 degrees above the horizon (overhead), and progressively increases as the angle above the horizon is reduced to zero where delay errors may be as much as 50 metres at the horizon.
- **Ephemeris Errors** – Some degree of error always exists between the broadcast ephemeris’ predicted satellite position and the actual orbit position of the satellites. These errors will directly affect the accuracy of the range measurement.
- **Satellite Clock Errors** – Some degree of error also exists between the actual satellite clock time and the clock time predicted by the broadcast data. This broadcast time error will cause some bias to the pseudorange measurements.
- **Receiver Clock Errors** – Receiver clock error is the time difference between GPS receiver time and true GPS time. All GPS receivers have differing clock offsets from GPS time that vary from receiver to receiver by an unknown amount depending on the oscillator type and quality (TCXO versus OCXO, and so on). However, because a receiver makes all of its single-point pseudorange measurements using the same common clock oscillator, all measurements will be equally offset, and this offset can generally be modeled or quite accurately estimated to effectively cancel the receiver clock offset bias. Thus, in single-point positioning, receiver clock offset is not a significant problem.
- **Multipath Signal Reception** – Multipath signal reception can potentially cause large pseudorange and carrier phase measurement biases. Multipath conditions are very much a function of specific antenna site location versus local geography and man-made structural influences. Severe multipath conditions could skew range measurements by as much as 100 meters or more. Refer to the *Multipath* section of the *GPS+ Reference Manual* for more information.

6.2 Satellite-Based Augmentation System (SBAS)

A Satellite-Based Augmentation System (SBAS) is a type of geo-stationary satellite system that improves the accuracy, integrity, and availability of the basic GPS signals. Accuracy is enhanced through the use of wide area corrections for GPS satellite orbits and ionospheric errors. Integrity is enhanced by the SBAS network quickly detecting satellite signal errors and sending alerts to receivers to not use the failed satellite. Availability is improved by providing an additional ranging signal to each SBAS geostationary satellite.

SBAS includes the Wide-Area Augmentation System (WAAS), the European Geo-Stationary Navigation System (EGNOS), and the MTSAT Satellite-Based Augmentation System (MSAS). At the time of publication, there are two WAAS satellites over the western Atlantic Ocean and the Pacific (PRN 122 and PRN 134 respectively) and one EGNOS satellite over the eastern Atlantic Ocean (PRN 120). SBAS data is available from any of these satellites and more satellites will be available in the

future.

The primary functions of SBAS include:

- data collection
- determining ionospheric corrections
- determining satellite orbits
- determining satellite clock corrections
- determining satellite integrity
- independent data verification
- SBAS message broadcast and ranging
- system operations & maintenance

As shown in *Figure 16, The SBAS Concept on Page 69*, the SBAS is made up of a series of Reference Stations, Master Stations, Ground Uplink Stations and Geostationary Satellites (GEOs). The Reference Stations, which are geographically distributed, pick up GPS satellite data and route it to the Master Stations where wide area corrections are generated. These corrections are sent to the Ground Uplink Stations which up-link them to the GEOs for re-transmission on the GPS L1 frequency. These GEOs transmit signals which carry accuracy and integrity messages, and which also provide additional ranging signals for added availability, continuity and accuracy. These GEO signals are available over a wide area and can be received and processed by OEM4 family GPS receivers with appropriate firmware. GPS user receivers are thus able to receive SBAS data in-band and use not only differential corrections, but also integrity, residual errors and ionospheric information for each monitored satellite.

The signal broadcast via the SBAS GEOs to the SBAS users is designed to minimize modifications to standard GPS receivers. As such, the GPS L1 frequency (1575.42 MHz) is used, together with GPS-type modulation - for example, a Coarse/Acquisition (C/A) pseudorandom (PRN) code. In addition, the code phase timing is maintained close to GPS time to provide a ranging capability.

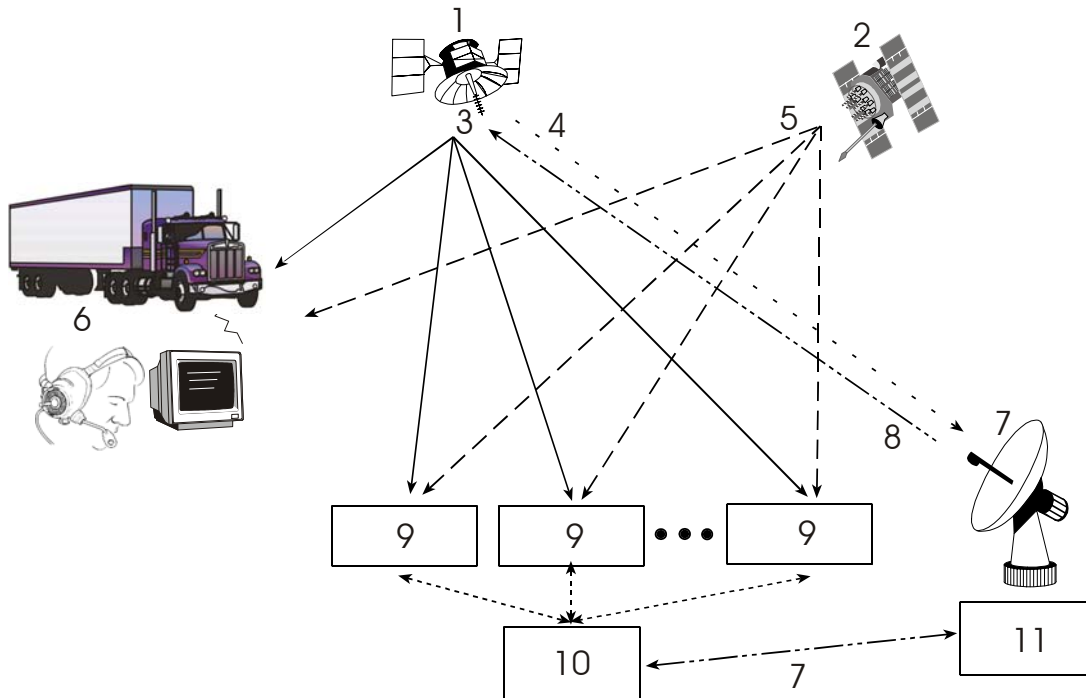

Figure 16: The SBAS Concept

Reference	Description	Reference	Description
1	Geostationary Satellite (GEO)	8	C-Band
2	GPS Satellite Constellation	9	SBAS Reference Station
3	L1	10	SBAS Master Station
4	L1 and C-Band	11	Ground Uplink Station
5	L1 and L2		
6	GPS User		
7	Integrity data, differential corrections and ranging control		

6.2.1 SBAS Receiver

Many models of the NovAtel receivers (including 3151W, L112W, WAAS, EGNOS) are equipped with an SBAS option. The ability to simultaneously track two SBAS satellites, and incorporate the SBAS corrections into the position, is available in these models.

These models can output the SBAS data in log format (RAWWAASFRAMEA/B, WAAS0A/B-WAAS27A/B), and can incorporate these corrections to generate differential-quality position solutions. Standard SBAS data messages are analyzed based on RTCA standard DO-229B Change 1 Minimum Operational Performance Standards for GPS/WAAS airborne equipment.

A SBAS-capable receiver will permit anyone within the area of coverage to take advantage of its benefits.

6.2.2 SBAS Commands and Logs

The command SBASCONTROL, enables the use of the SBAS corrections in the position filter. In order to use this command, first ensure that your receiver is capable of receiving SBAS corrections.

Several SBAS specific logs also exist and are all prefixed by the word WAAS except for the RAWWAASFRAME log.

The PSRDIFFSOURCE command sets the station ID value which identifies the base station from which to accept pseudorange corrections. All DGPS types may revert to SBAS, if enabled using the SBASCONTROL command.

Consult *Volume 2* of this manual set for more details on individual SBAS commands and logs.

6.3 Pseudorange Differential

There are two types of differential positioning algorithms: *pseudorange* and *carrier phase*. In both of these approaches, the “quality” of the positioning solution generally increases with the number of satellites which can be simultaneously viewed by both the base and rover station receivers. As well, the quality of the positioning solution increases if the distribution of satellites in the sky is favorable; this distribution is quantified by a figure of merit, the Position Dilution of Precision (PDOP), which is defined in such a way that the lower the PDOP, the better the solution. Pseudorange differential is the focus of this section. Carrier-phase algorithms are discussed in *Carrier-Phase Differential* on Page 79.

6.3.1 Pseudorange Algorithms

Pseudorange algorithms correlate the pseudorandom code on the GPS signal received from a particular satellite, with a version generated within the base station receiver itself. The time delay between the two versions, multiplied by the speed of light, yields the *pseudorange* (so called because it contains several errors) between the base station and that particular satellite. The availability of four pseudoranges allows the base station receiver to compute its position (in three dimensions) and the offset required to synchronize its clock with GPS system time. The discrepancy between the base station receiver’s computed position and its known position is due to errors and biases on each pseudorange. The base station receiver calculates these errors and biases for each pseudorange, and then broadcasts these corrections to the rover station. The rover receiver applies the corrections to its own measurements; its corrected pseudoranges are then processed in a least-squares algorithm to obtain a position solution.

The “wide correlator” receiver design that predominates in the GPS industry yields accuracies of 3-5 m (SEP). NovAtel’s patented Narrow Correlator tracking technology reduces noise and multipath interference errors, yielding accuracies of 1 m (SEP).

6.3.2 Position Solutions

Due to the many different applications for differential positioning systems, two types of position solutions are possible. NovAtel’s carrier-phase algorithms can generate both *matched* and *low-latency* position solutions, while NovAtel’s pseudorange algorithms generate only low-latency solutions. These are described below:

1. The *matched* position solution is computed at the rover station when the observation information for a given epoch has arrived from the base station via the data link. Matched observation set pairs are observations by both the base and rover stations which are matched by time epoch, and contain the same satellites. The matched position solution is the most accurate one available to the operator of the rover station, but it has an inherent *latency* – the sum of time delays between the moment that the base station makes an observation and the moment that the differential information is processed at the rover station. This latency depends on the computing speed of the base station receiver, the rates at which data is transmitted through the various links, and the computing speed of the rover station; the overall delay is on the order of one second. Furthermore, this position cannot be computed any more often than the observations are sent from the base station. Typically, the update rate is one solution every two seconds.
2. The *low latency* position solution is based on a prediction from the base station. Instead of waiting for the observations to arrive from the base station, a model (based on previous base station observations) is used to estimate what the observations will be at a given time epoch. These estimated base station observations are combined with actual measurements taken at the rover station to provide the position solution. Because only the base station observations are predicted, the rover station's dynamics will be accurately reflected. The *latency* in this case (the time delay between the moment that a measurement is made by the rover station and the moment that a position is made available) is determined only by the rover processor's computational capacity; the overall delay is of the order of a hundred milliseconds. Low-latency position solutions can be computed more often than matched position solutions. The low-latency positions will be provided for data gaps between matched positions of up to 60 seconds (for a carrier-phase solution) or 300 seconds (for a pseudorange solution, unless adjusted using the DGPSTIMEOUT command). A general guideline for the additional error incurred due to the extrapolation process is shown in *Table 11*.

Table 11: Latency-Induced Extrapolation Error

Time since last base station observation	Typical extrapolation error (CEP) rate
0-2 seconds	1 cm/s
2-7 seconds	2 cm/s
7-30 seconds	5 cm/s

6.3.3 Dual Station Differential Positioning

It is the objective of operating in differential mode to either eliminate or greatly reduce most of the errors introduced by the system biases discussed in *GPS System Errors* on Page 66. Pseudorange differential positioning is quite effective in removing most of the biases caused by satellite clock error, ionospheric and tropospheric delays (for baselines less than 50 km), and ephemeris prediction errors. However, the biases caused by multipath reception and receiver clock offset are uncorrelated between receivers and thus cannot be cancelled by "between receiver single differencing" operation.

Differential operation requires that stations operate in pairs. Each pair consists of a base station and a rover station. A differential network could also be established when there is more than one rover station linked to a single base station.

In order for the differential pair to be effective, differential positioning requires that both base and rover station receivers track and collect satellite data simultaneously from common satellites. When the two stations are in relatively close proximity (< 50 km), the pseudorange bias errors are considered

to be nearly the same and can be effectively cancelled by the differential corrections. However, if the baseline becomes excessively long, the bias errors begin to decorrelate, thus reducing the accuracy or effectiveness of the differential corrections.

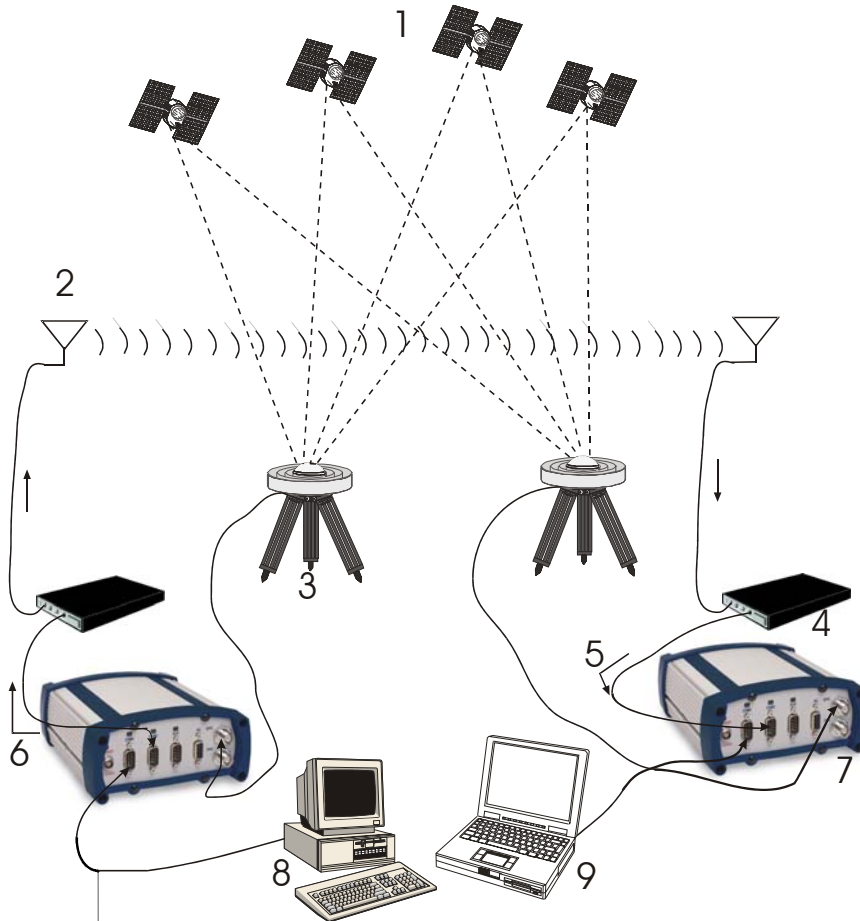

Figure 17: Typical Differential Configuration

Reference	Description
1	GPS Constellation
2	Radio Data Link
3	GPS Antenna with Choke Ring
4	Modem
5	Differential Corrections Input
6	Differential Corrections Output
7	GPS Receiver
8	Base Station
9	Rover Station

6.3.3.1 The Base Station

The nucleus of the differential network is the base station. To function as a base station, the GPS receiver antenna must be positioned at a control point whose position is precisely known in the GPS reference frame. Typically, the fixed position will be that of a geodetic marker or a pre-surveyed point of known accuracy.

The base receiver must then be initialized to fix its position to agree with the latitude, longitude, and height of the phase centre of the base station GPS receiver antenna. Of course, the antenna offset position from the marker must be accurately accounted for.

Because the base station's position is fixed at a known location, it can now *compute* the range of its known position to the satellite. The base station now has two range measurements with which to work: *computed pseudoranges* based on its known position relative to the satellite, and *measured pseudoranges* which assumes the receiver position is unknown. Now, the base station's measured pseudorange (unknown position) is differenced against the computed range (based on known position) to derive the differential correction which represents the difference between known and unknown solutions for the same antenna. This difference between the two ranges represents the combined pseudorange measurement errors resulting from receiver clock errors, atmospheric delays, satellite clock error, and orbital errors.

The base station will derive pseudorange corrections for each satellite being tracked. These corrections can now be transmitted over a data link to one or more rover stations. It is important to ensure that the base station's FIX POSITION setting be as accurate as possible, as any errors here will directly bias the pseudorange corrections computed, and can cause unpredictable results depending on the application and the size of the base station position errors. As well, the base station's pseudorange measurements may be biased by multipath reception.

6.3.3.2 The Rover Station

A rover station is generally any receiver whose position is of unknown accuracy, but has ties to a base station through an established data link. If the rover station is not receiving differential corrections from the base station, it is essentially utilizing single-point positioning measurements for its position solutions, thus is subject to the various GPS system biases. However, when the rover GPS receiver is receiving a pseudorange correction from the base station, this correction is applied to the local receiver's measured pseudorange, effectively cancelling the effects of orbital and atmospheric errors (assuming baselines < 50 km), as well as eliminating satellite clock error.

The rover station must be tracking the same satellites as the base station in order for the corrections to take effect. Thus, only common satellite pseudoranges will utilize the differential corrections. When the rover is able to compute its positions based on pseudorange corrections from the base station, its position accuracies will approach that of the base station. Remember, the computed position solutions are always that of the GPS receiving antenna phase centre.

6.4 L-Band Positioning

The transmission of OmniSTAR or CDGPS corrections are from geostationary satellites. The L-Band frequency of geostationary satellites is sufficiently close to that of GPS that a common, single antenna, like the NovAtel GPS-702L, may be used.

Both systems are portable and capable of sub-meter accuracy over their coverage areas.

The OmniSTAR system is designed for worldwide coverage. A subscription charge by geographic area is required. The CDGPS system is a free Canada-wide DGPS service that is accessible coast-to-coast, beyond the U.S. border, and into the Arctic.

6.4.1 Coverage

The two systems provide different coverage areas:

- Worldwide OmniSTAR
- Canada/America-Wide CDGPS

6.4.1.1 Worldwide OmniSTAR

In most world areas, a single satellite is used by OmniSTAR to provide coverage over an entire continent - or at least very large geographic areas. In North America, a single satellite is used, but it needs three separate beams to cover the continent. The three beams are arranged to cover the East, Central, and Western portions of North America. The same data is broadcast over all three beams, but the user system must select the proper beam frequency. The beams have overlaps of several hundred miles, so the point where the frequency must be changed is not critical.

The North American OmniSTAR Network currently consists of ten permanent base stations in the Continental U.S., plus one in Mexico. These eleven stations track all GPS satellites above 5 degrees elevation and compute corrections every 600 milliseconds. The corrections are sent to the OmniSTAR Network Control Center (NCC) in Houston via wire networks. At the NCC these messages are checked, compressed, and formed into packets for transmission up to the OmniSTAR satellite transponder. This occurs approximately every few seconds. A packet will contain the latest corrections from each of the North American base stations.

All of the eastern Canadian Provinces, the Caribbean Islands, Central America (south of Mexico), and South America is covered by a single satellite (AM-Sat). A single subscription is available for all the areas covered by this satellite.

OmniSTAR currently has several high-powered satellites in use around the World. They provide coverage for most of the World's land areas. Subscriptions are sold by geographic area. Any Regional OmniSTAR service center can sell and activate subscriptions for any area. They may be arranged prior to traveling to a new area, or after arrival. Contact OmniSTAR at www.omnistar.com for further details.

The OmniStar beam frequency chart can be found at http://www.omnistar.com/setup_osrc.html.

6.4.1.2 Canada/America-Wide CDGPS

The CDGPS service utilizes the MSAT-1 and MSAT-2 communications satellites.

In order to enable CDGPS positioning, you must enable L-band tracking to the CDGPS signal. The CDGPS signal is broadcast on 4 different spot beams on the MSAT-1 satellite. Depending on your geographic location, there will be a different frequency for the CDGPS signal as shown in *Figure 18*.

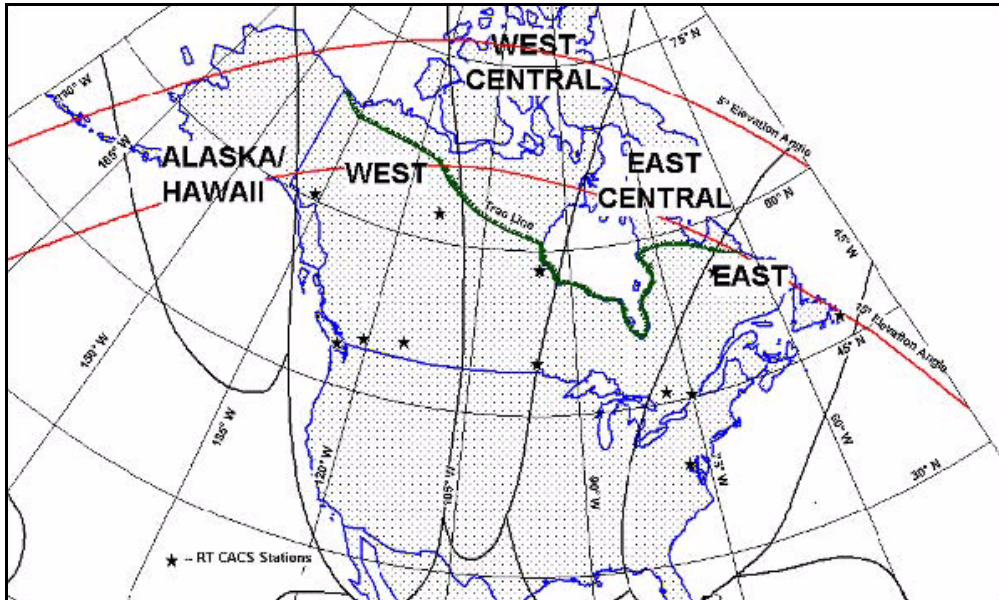

Figure 18: CDGPS Frequency Beams

The following are the spot beam names and their frequencies:

East	1,547,646 Hz
East-Central	1,557,897 Hz
West-Central	1,557,571 Hz
West	1,547,547 Hz

The data signal is structured to perform well in difficult, or foliated conditions, so the service is available more consistently and has a high degree of service reliability.

CDGPS features wide area technology, possible spatial integrity with all Government of Canada maps and surveys¹, 24-hour/7 days-a-week built-in network redundancies and an openly published broadcast protocol.

Figure 19, CDGPS Percentage Coverage Map on Page 76 is a conservative map of the coverage areas that CDGPS guarantee. The coverage may be better in your area.

1. If the coordinates are output using the CSRS datum. Refer to the DATUM command in *Volume 2* of this manual set.

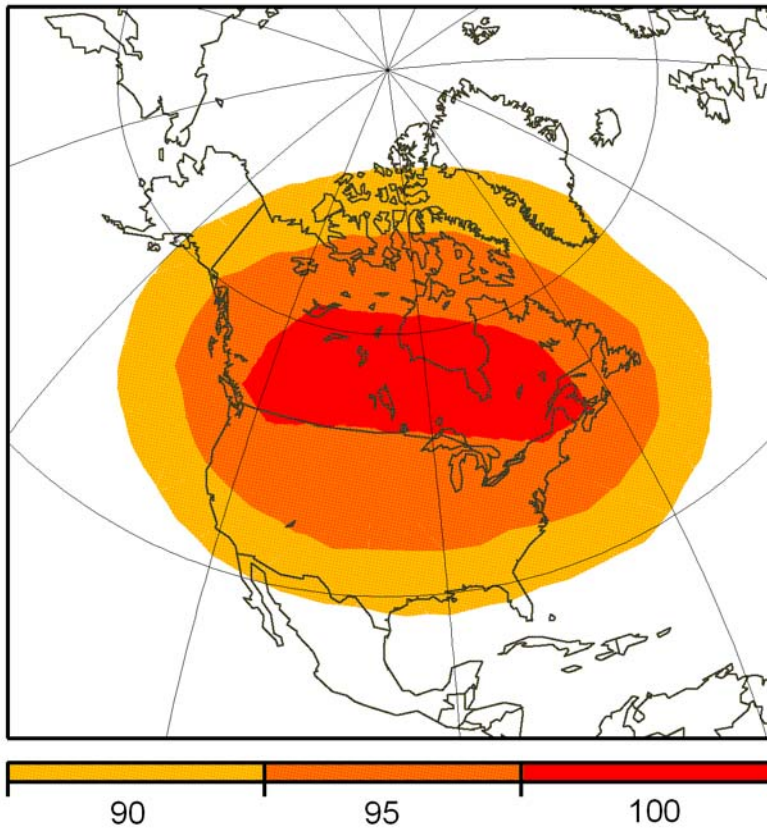

Figure 19: CDGPS Percentage Coverage Map

In *Figure 19*, 100% coverage means that a correction is received for every visible satellite (at or above 10 degrees). 90% coverage means that a correction is received for 90% of visible satellites. For example, if a user views 10 satellites but has 90% coverage then there are no corrections available for one of the satellites. In that case, our firmware shows that a correction is missing for that SV and excludes it from the position calculation.

6.4.2 L-Band Service Levels

Two levels of service are available:

- | | | |
|------------------|---|--|
| Standard | - | Sub-meter accuracy from OmniSTAR VBS and CDGPS |
| High Performance | - | Decimeter to sub-decimeter accuracy from OmniSTAR XP and HP respectively |

6.4.2.1 Standard Service

The OmniSTAR VBS service uses multiple GPS base stations in a solution and reduces errors due to the GPS signals traveling through the atmosphere. It uses a wide area DGPS solution (WADGPS) and data from a relatively small number of base stations to provide consistent accuracy over large areas. A unique method of solving for atmospheric delays and weighting of distant base stations achieves sub-meter capability over the entire coverage area - regardless of your location relative to any base station. This achieves a truly wide-area system with consistent characteristics.

CDGPS is able to simultaneously track two satellites, and incorporate the corrections into the position. The output is SBAS-like (see WAAS32-WAAS45 in *Volume 2* of this manual set), and can incorporate these corrections to generate differential-quality position solutions. CDGPS allows anyone within the area of coverage to take advantage of its benefits.

NovAtel's ProPak-LBplus provides GPS with L-Band corrections in one unit, using a common antenna. This means that, with CDGPS or a subscription to the OmniSTAR VBS service, the ProPak-LBplus is a high quality receiver with sub-meter capabilities.

The position from the GPSCard in the receiver is used as the L-Band system's first approximation.

After the L-Band processor has taken care of the atmospheric corrections, it then uses its location versus the base station locations, in an inverse distance-weighted least-squares solution. L-Band technology generates corrections optimized for the location. It is this technique that enables the L-Band receiver to operate independently and consistently over the entire coverage area without regard to where it is in relation to the base stations.

6.4.2.2 High Performance Service

The OmniSTAR High Performance (HP) service gives you more accuracy than the OmniSTAR VBS or CDGPS services. OmniSTAR HP computes corrections in dual-frequency RTK float mode (within about 10 cm accuracy). The XP service is similar to HP but less accurate (15 cm) and more accurate than VBS (1 m). To obtain OmniSTAR HP or XP corrections, your receiver must have an HP or XP subscription from OmniSTAR.

-
- ☒ For optimal performance, allow the OmniSTAR HP solution to converge prior to starting any dynamic operation.
-

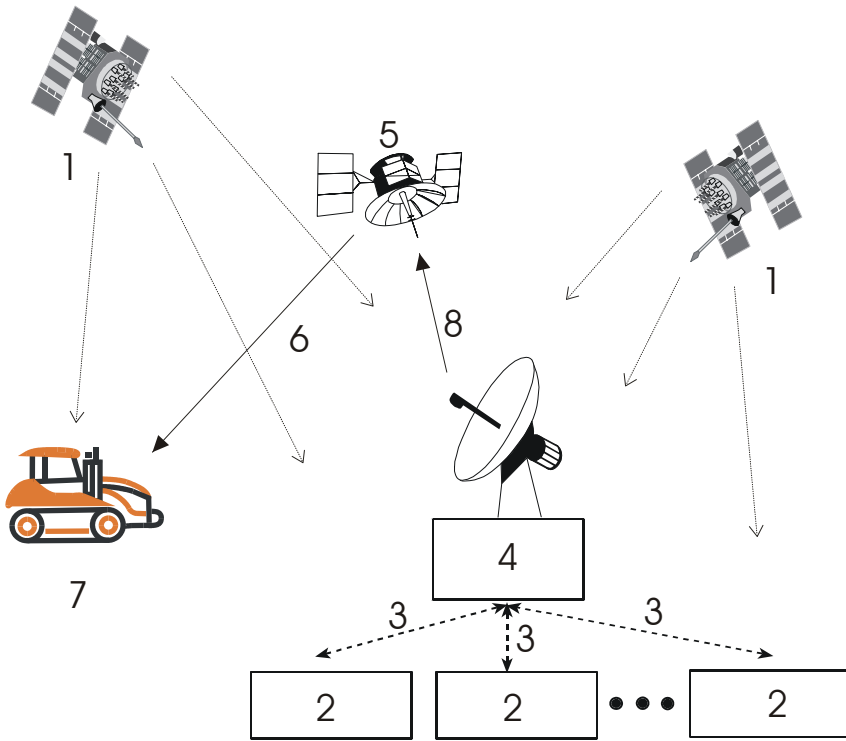

Figure 20: OmniSTAR Concept

Reference	Description
1	GPS satellites
2	Multiple L-Band ground stations
3	Send GPS corrections to 4
4	Network Control Center where data corrections are checked and repackaged for uplink to 5
5	L-Band Geostationary Satellite
6	L-Band DGPS signal
7	Correction data are received and applied real-time
8	DGPS uplink

6.4.3 L-Band Commands and Logs

The ASSIGNL BAND command allows you to set OmniSTAR or CDGPS base station communication parameters. It should include relevant frequencies, for example:

```
assignlband omnistar 1536782 1200
```

or,

```
assignlband cdgps 1547547 4800
```

-
- ☒ OmniSTAR has changed channels (frequencies) on the AMSC Satellite that broadcasts OmniSTAR corrections for North America. NovAtel receivers do not need a firmware change. To change frequencies, connect your receiver and issue an ASSIGNLBAND command. For example, the Western Beam frequency as stated on Omnistar's website is 1536.7820 MHz. Input into the receiver: `assignlband omnistar 1536782 1200`
-

The PSRDIFFSOURCE command lets you identify from which base station to accept RTCA1, RTCM1, CDGPS or OmniSTAR VBS differential corrections. For example, in the PSRDIFFSOURCE command, OMNISTAR enables OmniSTAR VBS and disables other DGPS types. OmniSTAR VBS produces RTCM-type corrections. CDGPS produces WAAS-type corrections. AUTO means the first received RTCM or RTCA message has preference over an OmniSTAR VBS or CDGPS message.

The RTKSOURCE command lets you identify from which base station to accept RTK (RTCM, RTCA, CMR and OmniSTAR HP) differential corrections. For example, in the RTKSOURCE command, OMNISTAR enables OmniSTAR HP, if allowed, and disables other RTK types. OmniSTAR HP computes corrections in RTK float mode or within about 10 cm accuracy. For RTK models, AUTO means the NovAtel RTK filter is enabled and the first received RTCM, RTCA or CMR message is selected. For non-RTK models, AUTO means the OmniSTAR HP message, if allowed, is enabled.

The PSRDIFFSOURCE and RTKSOURCE commands are useful when the receiver is receiving corrections from multiple base stations.

Several L-Band specific logs also exist and are prefixed by the letters RAWLBAND, LBAND or OMNI. CDGPS corrections are output similarly to SBAS corrections. There are four SBAS fast corrections logs (WAAS32-WAAS35) and one slow corrections log (WAAS45) for CDGPS. The CDGPS PRN is 209.

-
- ☒ In addition to a NovAtel receiver with L-Band capability, a subscription to the OmniSTAR, or use of the free CDGPS, service is required. Contact NovAtel for details, see *Page 12*.
-

Consult *Volume 2* of this manual set for more details on individual L-Band commands and logs.

6.5 Carrier-Phase Differential

Carrier-phase algorithms monitor the actual carrier wave itself. These algorithms are the ones used in real-time kinematic (RTK) positioning solutions - differential systems in which the rover station, possibly in motion, requires base-station observation data in real-time. Compared to pseudorange algorithms, much more accurate position solutions can be achieved: carrier-based algorithms can achieve accuracies of 1-2 cm (CEP).

Kinematic GPS using carrier-phase observations is usually applied to areas where the relation between physical elements and data collected in a moving vehicle is desired. For example, carrier-phase kinematic GPS missions have been performed in aircraft to provide coordinates for aerial photography, and in road vehicles to tag and have coordinates for highway features. This method can achieve similar accuracy to that of static carrier-phase, if the ambiguities can be fixed. However,

satellite tracking is much more difficult, and loss of lock makes reliable ambiguity solutions difficult to maintain.

A carrier-phase measurement is also referred to as an *accumulated delta range* (ADR). At the L1 frequency, the wavelength is 19 cm; at L2, it is 24 cm. The instantaneous distance between a GPS satellite and a receiver can be thought of in terms of a number of wavelengths through which the signal has propagated. In general, this number has a fractional component and an integer component (such as 124 567 967.330 cycles), and can be viewed as a pseudorange measurement (in cycles) with an initially unknown constant integer offset. Tracking loops can compute the fractional component and the change in the integer component with relative ease; however, the determination of the initial integer portion is less straight-forward and, in fact, is termed the *ambiguity*.

In contrast to pseudorange algorithms where only corrections are broadcast by the base station, carrier-phase algorithms typically “double difference” the actual observations of the base and rover station receivers. Double-differenced observations are those formed by subtracting measurements between identical satellite pairs on two receivers:

$$\text{ADR}_{\text{double difference}} = (\text{ADR}_{\text{rx A,sat i}} - \text{ADR}_{\text{rx A,sat j}}) - (\text{ADR}_{\text{rx B,sat i}} - \text{ADR}_{\text{rx B,sat j}})$$

An ambiguity value is estimated for each double-difference observation. One satellite is common to every satellite pair; it is called the *reference* satellite, and it is generally the one with the highest elevation. In this way, if there are n satellites in view by both receivers, then there will be $n-1$ satellite pairs. The difference between receivers A and B removes the correlated noise effects, and the difference between the different satellites removes each receiver’s clock bias from the solution.

In the RTK system, a *floating* (or “*continuous-valued*”) *ambiguity solution* is continuously generated from a Kalman filter. When possible, *fixed-integer ambiguity solutions* are also computed because they are more accurate, and produce more robust standard-deviation estimates. Each possible discrete ambiguity value for an observation defines one *lane*. That is, each lane corresponds to a possible pseudorange value. There are a large number of possible lane combinations, and a receiver has to analyze each possibility in order to select the correct one. For single-frequency receivers, there is no alternative to this brute-force approach. However, one advantage of being able to make both L1 and L2 measurements is that linear combinations of the measurements made at both frequencies lead to additional values with either “wider” or “narrower” lanes. Fewer and wider lanes make it easier for the software to choose the correct lane, having used the floating solution for initialization. Once the correct *wide lane* has been selected, the software searches for the correct *narrow lane*. Thus, the searching process can more rapidly and accurately home in on the correct lane when dual-frequency measurements are available. Changes in the geometry of the satellites aids in ambiguity resolution; this is especially noticeable in L1-only solutions. In summary, NovAtel’s RTK system permits L1/L2 receivers to choose integer lanes while forcing L1-only receivers to rely exclusively on the floating ambiguity solution.

Once the ambiguities are known, it is possible to solve for the vector from the base station to the rover station. This baseline vector, when added to the position of the base station, yields the position of the rover station.

In the NovAtel RTK system, the floating ambiguity and the integer position solutions (when both are available) are continuously compared for integrity purposes. The better one is chosen and output in the receiver’s matched-position logs. The “best” ambiguities determined are used with the rover station’s local observations and a base station observation model to generate the rover station’s low-

latency observations.

6.5.1 Real-Time Kinematic (RTK)

RT-2 and RT-20 are real-time kinematic software products developed by NovAtel. They can only be used in conjunction with NovAtel GPS receivers. A quick comparison of RT-2 and RT-20 is shown in the following table:

Table 12: Comparison of RT-2 and RT-20

	RT-2	RT-20
GPS Frequencies Utilized	L1 & L2	L1
Nominal Accuracy	2 cm (CEP)	20 cm (CEP)
Lane Searching	Wide lane and narrow lane	None

NovAtel’s RTK software algorithms utilize both carrier and code phase measurements; thus, the solutions are robust, reliable, accurate and rapid. While both RT-20 and RT-2 operate along similar principles, RT-2 achieves its extra accuracy and precision due to its being able to utilize dual-frequency measurements. Dual-frequency GPS receivers have two main advantages over their single-frequency counterparts when running RTK software:

1. resolution of cycle ambiguity is possible due to the use of wide lane searching
2. longer baselines are possible due to the removal of ionospheric errors

Depending on the transmitting/receiving receivers and the message content, various levels of accuracy can be obtained. Please refer to the particular accuracy as shown in the following table:

Table 13: Summary of RTK Messages and Expected Accuracy

Message Formats	Transmitting (Base)	Receiving (Rover)	Accuracy Expected
L1 and L2 RTK: RTCAOBS with RTCAREF RTCM Types 18 and 19 with Types 3 and 22 RTCM Types 20 and 21 CMROBS with CMRREF	L1 and L2	RT-2	2 cm CEP (RT-2)
		RT-20	20 cm CEP (RT-20)
	L1 only	RT-2 or RT-20	20 cm CEP (RT-20)
L1 RTK: RTCM Type 59 with Type 3	L1 and L2 or L1 only	RT-2 or RT-20	20 cm CEP (RT-20)
L1 Pseudorange Corrections: RTCM Type 1 RTCA Type 1	L1 and L2 or L1 only	Any differential enabled OEM4	1 m SEP (DGPS)

The RTK system in the receiver provides two kinds of position solutions. The Matched RTK position is computed with buffered observations, so there is no error due to the extrapolation of base station measurements. This provides the highest accuracy solution possible at the expense of some latency which is affected primarily by the speed of the differential data link. The MATCHEDPOS log contains the matched RTK solution and can be generated for each processed set of base station observations. The RTKDATA log provides additional information about the matched RTK solution.

The Low-Latency RTK position and velocity are computed from the latest local observations and extrapolated base station observations. This supplies a valid RTK position with the lowest latency possible at the expense of some accuracy. The degradation in accuracy is reflected in the standard deviation and is summarized in *Section 6.3.2, Position Solutions on Page 70*. The amount of time that the base station observations are extrapolated is provided in the "differential lag" field of the position log. The Low-Latency RTK system will extrapolate for 60 seconds. The RTKPOS log contains the Low-Latency RTK position when valid, and an "invalid" status when a low-latency RTK solution could not be computed. The BESTPOS log contains the low-latency RTK position when it is valid, and superior to the pseudorange-based position. Otherwise, it will contain the pseudorange-based position. Similarly, RTKVEL and BESTVEL will contain the low-latency RTK velocity.

RT-20 solutions will always use floating L1 ambiguities. When valid L2 measurements are available, RT-2 solutions will have other solution types that depend on convergence time, baseline length, number of satellites, satellite geometry and the level of ionospheric activity detected.

6.5.1.1 RT-2 Performance

The RT-2 software provides the accuracies shown in *Table 14, RT-2 Performance: Static Mode on Page 83, Figure 21, Typical RT-2 Horizontal Convergence - Static Mode on Page 84, Table 15, RT-2 Performance: Kinematic Mode on Page 83 and Figure 22, Typical RT-2 Horizontal Convergence - Kinematic Mode on Page 84* for typical multipath, ionospheric, tropospheric, and ephemeris errors, where typical is described as follows:

- A typical multipath environment would provide no carrier-phase double-difference multipath errors greater than 2 cm or pseudorange double-difference multipath errors greater than 2 m on satellites at 11° elevation or greater. For environments where there is greater multipath, please consult NovAtel Customer Service.
- Typical unmodeled ionospheric, tropospheric and ephemeris errors must be within 2σ of their average values, at a given elevation angle and baseline length. It is assumed that the tropospheric correction is computed with standard atmospheric parameters. All performance specifications assume that at least 6 satellites above the mask angle (varies between 11 and 14 degrees) are being tracked on both L1 and L2.

In *Table 14, RT-2 Performance: Static Mode* and *Table 15, RT-2 Performance: Kinematic Mode on Page 83*, accuracy values refer to horizontal RMS error. The level of position accuracy at any time will be reflected in the standard deviations output with the position.

Table 14: RT-2 Performance: Static Mode

Baseline length	Horizontal accuracy
< 5 km	2 cm + 0.5 ppm
< 10 km	1 cm + 1 ppm
< 15 km	5 cm
< 25 km	7 cm
< 35 km	35 cm
< 35 km	25 cm

Table 15: RT-2 Performance: Kinematic Mode

Baseline length	Horizontal accuracy
< 5 km	2 cm + 0.5 ppm
< 10 km	2 cm + 0.5 ppm
< 15 km	8 cm
< 25 km	10 cm
< 35 km	40 cm
< 35 km	25 cm

RTKPOS or BESTPOS logs contain some error due to predictions from base station observations. The expected error of a RTKPOS or BESTPOS log will be that of the corresponding MATCHEDPOS log plus the appropriate error from *Table 16*.

There are no data delays for a matched log and therefore no need to add an additional error factor.

Table 16: RT-2 Degradation With Respect To Data Delay

Data Delay (s)	Distance (km)	Accuracy (CEP)
0 - 2	1	+1 cm/s
2 - 7	1	+2 cm/s
7 - 30	1	+5 cm/s
>60	1	single point or pseudorange differential positioning ²

¹ Mode = Static or Kinematic

² After 60 seconds reverts to pseudorange positioning (single point or differential depending on messages previously received from the base station).

For baselines under 30 km long, the RT-2 solution shows two pronounced steps in accuracy convergence; these correspond to the single-point solution switching to the floating ambiguity solution which in turn switches to the narrow or wide lane solution. If you were monitoring this using NovAtel’s *GPSolution* program, the convergence sequence might look something like this:

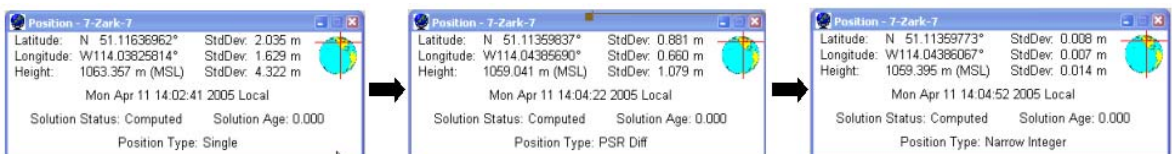

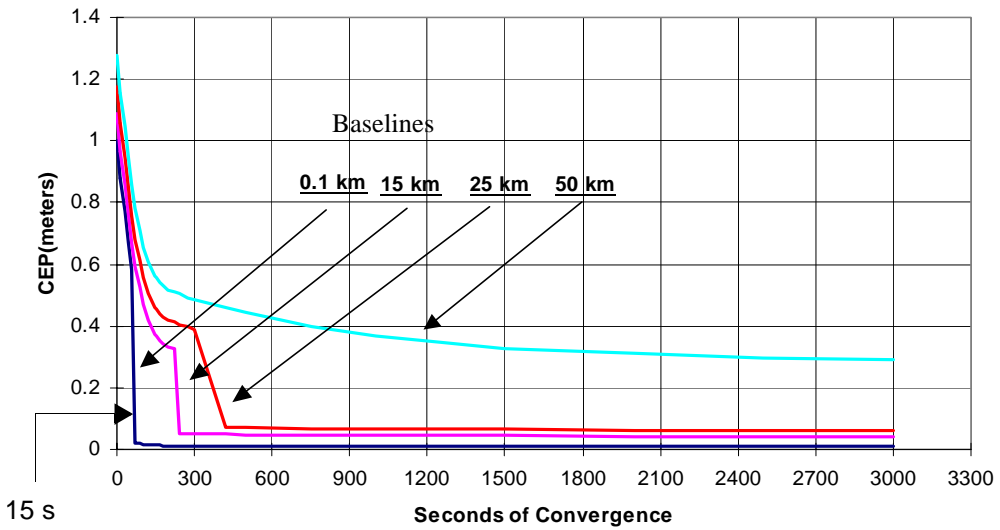

Figure 21: Typical RT-2 Horizontal Convergence - Static Mode

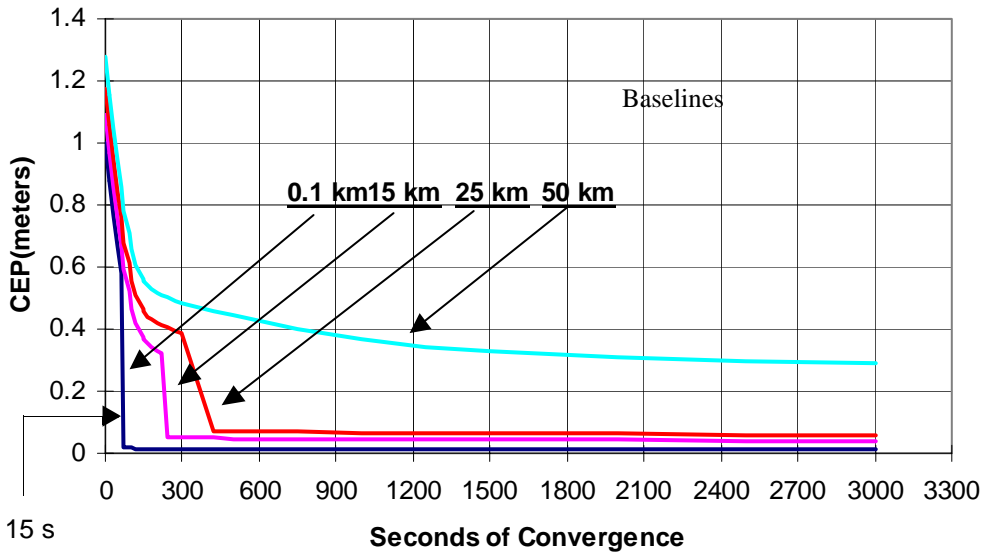

Figure 22: Typical RT-2 Horizontal Convergence - Kinematic Mode

6.5.1.2 RT-20 Performance

As shown in *Table 17, RT-20 Performance* below, *Figure 23, Typical RT-20 Convergence - Static Mode* on *Page 86* and *Figure 24, Typical RT-20 Convergence - Kinematic Mode* on *Page 86* the RT-20 system provides nominal 20 cm accuracy (CEP) after 3 minutes of continuous lock in static mode. After an additional period of continuous tracking (from 10 to 20 minutes), the system typically reaches steady state and position accuracies in the order of 3 to 4 cm. The time to steady state is about 3 times longer in kinematic mode.

RT-20 double-difference accuracies are based on PDOP < 2 and continuous tracking of at least 5 satellites (6 preferred) at elevations of at least 11.5°.

All accuracy values refer to horizontal RMS error, and are based on low-latency positions. The level of position accuracy at any time will be reflected in the standard deviations output with the position.

Table 17: RT-20 Performance

Tracking Time (s)	Mode ¹	Data Delay (s)	Distance (km)	Accuracy (CEP)
1 - 180	Static	0	1	45 to 25 cm
180 - 3000	Static	0	1	25 to 5 cm
> 3000	Static	0	1	5 cm or less ²
1 - 600	Kinematic	0	1	45 to 25 cm
600 - 3000	Kinematic	0	1	25 to 5 cm
> 3000	Kinematic	0	1	5 cm or less ²
	Either	0 - 2	1	+1 cm/s
	Either	2 - 7	1	+2 cm/s
	Either	7 - 30	1	+5 cm/s
	Either	> 30	1	pseudorange or single point ³
	Either	0	0 - 10	+0.5 cm/km
	Either	0	10 - 20	+0.75 cm/km
	Either	0	20 - 50	+1.0 cm/km

- 1 Mode = Static or Kinematic (during initial ambiguity resolution)
- 2 The accuracy specifications refer to the BESTPOSA/B logs which include about 3 cm extrapolation error. MATCHEDPOSA/B logs are more accurate but have increased latency associated with them.
- 3 After 60 seconds reverts to pseudorange positioning (single point or differential depending on messages previously received from the base station).

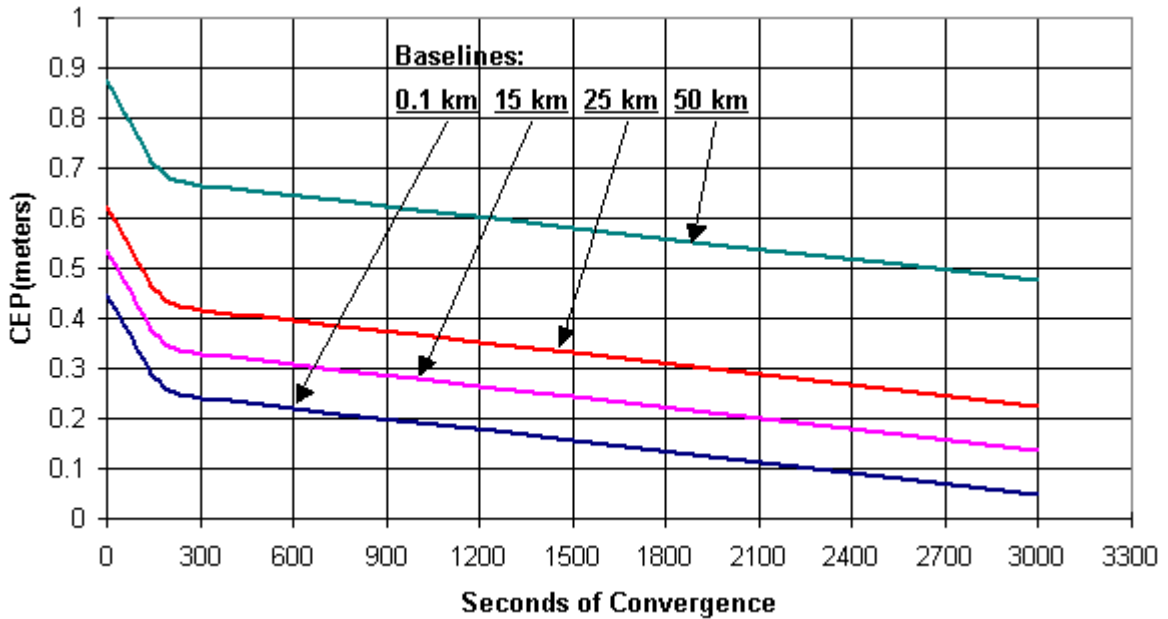

Figure 23: Typical RT-20 Convergence - Static Mode

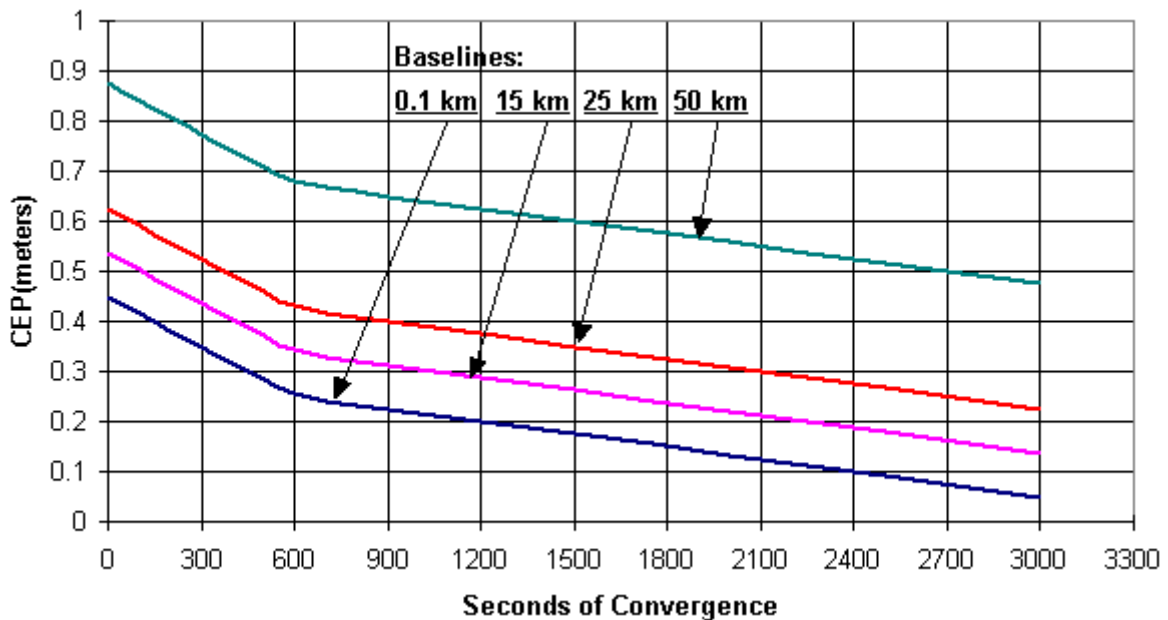

Figure 24: Typical RT-20 Convergence - Kinematic Mode

6.5.1.3 Performance Considerations

When referring to the “performance” of RTK software, two factors are introduced:

1. *Baseline length*: the position estimate becomes less precise as the baseline length increases. Note that the baseline length is the distance between the *phase centres* of the two antennas. Identifying the exact position of your antenna’s phase centre is essential; this information is typically supplied by the antenna’s manufacturer or vendor.

The RTK software automatically makes the transition between short and longer baselines, but the best results are obtained for baselines less than 10 km. The following are factors which are related to baseline length:

- ephemeris errors - these produce typical position errors of 0.75 cm per 10 km of baseline length.
- ionospheric effects - the dominant error for single-frequency GPS receivers on baselines exceeding 10 km. Differential ionospheric effects reach their peak at dusk and dawn, being at a minimum during hours of darkness. Ionospheric effects can be estimated and removed on dual-frequency GPS receivers, greatly increasing the permissible baseline length, but at the cost of introducing additional “noise” to the solution. Therefore, this type of compensation is only used in cases where the ionospheric error is much larger than the noise and multipath error.
- tropospheric effects - these produce typical position errors of approximately 1 cm per 10 km of baseline length. This error increases if there is a significant height difference between the base and rover stations, as well as if there are significantly different weather conditions between the two sites.

A related issue is that of multipath interference, the dominant error on short differential baselines. Generally, multipath can be reduced by choosing the antenna’s location with care, and by the use of the GPS-702 antenna (no need for a choke ring) or a L1/L2 antenna and a choke ring antenna ground plane, refer to the *Multipath* section of the *GPS+ Reference Manual*.

2. *Convergence time*: the position estimate becomes more accurate and more precise with time. However, convergence time is dependent upon baseline length: while good results are available after a minute or so for short baselines, the time required increases with baseline length. Convergence time is also affected by the number of satellites which can be used in the solution: the more satellites, the faster the convergence.

6.5.1.4 Performance Degradation

The performance will degrade if satellites are lost at the rover or if breaks occur in the differential correction transmission link. The degradations related to these situations are described in the following paragraphs.

Provided lock is maintained on at least 4 SVs and steady state has been achieved, the only degradation will be the result of a decrease in the geometrical strength of the observed satellite constellation. If steady state has not been achieved, then the length of time to ambiguity resolution under only 4-satellite coverage will be increased significantly.

ROVER TRACKING LOSS

If less than 4 satellites are maintained, then the RTK filter can not produce a position. When this

occurs, the BESTPOS and PSRPOS logs will be generated with differential (if pseudorange differential messages are transmitted with RTK messages) or single point pseudorange solutions if possible.

DIFFERENTIAL LINK BREAKDOWN

1. Provided the system is in steady state, and the loss of observation data is for less than 30 seconds, the Low-Latency RTK positions will degrade according to the divergence of the base observation extrapolation filters. This causes a decrease in accuracy of about an order of magnitude per 10 seconds without a base station observation, and this degradation is reflected in the standard deviations of the low latency logs. Once the data link has been re-established, the accuracy will return to normal after several samples have been received.
2. If the loss of differential corrections lasts longer than 30 seconds, the RTK filter is reset and all ambiguity and base model information is lost. The timeout threshold for RTK differential corrections is 60 seconds, but for Type 1 pseudorange corrections, the default timeout is 300 seconds. Therefore, when the RTK can no longer function because of this timeout, the pseudorange filter can produce differential positions for an additional 240 seconds by default (provided pseudorange differential messages were transmitted along with the RTK messages) before the system reverts to single point positioning. Furthermore, once the link is re-established, the pseudorange filter produces an immediate differential position while the RTK filter takes several additional seconds to generate its positions. The base model must be healthy before solutions are logged to the low latency logs, so there is a delay in the use of real time carrier positioning to the user once the link has been re-established. The RTK logs (MATCHEDPOSA/B) use matched observations only (no extrapolated observations), and these will be available after three base observations are received, but will have about 1.5 seconds latency associated with them.

The RTK system is based on a time-matched double difference observation filter. This means that observations at the rover site have to be buffered while the base station observation is encoded, transmitted, and decoded. Only 8 seconds of rover observations are saved, so the base station observation transmission process has to take less than 8 seconds if any time matches are to be made. In addition, only rover observations on even second boundaries are retained, so base station observations must also be sent on even seconds if time matches are to be made.

Visit the [Firmware and Software Updates](http://www.novatel.com) section of the NovAtel website, www.novatel.com, for the most recent versions of the PC software and receiver firmware.

7.1 GPSolution/Convert Installation

The CD accompanying this manual contains the Windows applications GPSolution and Convert. They are both installed via a standard Install Shield set-up application. Also included on the CD is sample source code, to aid development of software for interfacing with the receiver, and product documentation.

Both applications utilize a database in their operations so the necessary components of the Borland Database Engine (BDE) are installed as well as the necessary database tables and an alias for the database. The install set-up application does all this automatically so the user has only to select where they would like the applications installed on their PC. It is strongly recommended that you close all applications before installing GPSolution and Convert. You must close any applications that may be using the BDE before installing. The install set-up modifies the BDE configuration so that it can recognize the new GPSolution and Convert database.

The software operates from your PC's hard drive. You will need to install the software from the CD supplied by NovAtel:

1. Start Microsoft Windows.
2. Place the NovAtel CD in your CD-ROM drive. If the setup utility is not automatically accessible, follow these steps:
 - a. Select Run from the Start menu.
 - b. Select the Browse button.
 - c. Locate Setup.exe on the CD drive and select Open.
 - d. Select OK to run the setup utility.
3. Advance through the steps provided by the setup utility.

When the installation is complete, click on a program icon to launch the application.

7.2 GPSolution

GPSolution is a 32-bit Windows application. The application provides a graphical user interface to allow users to set-up and monitor the operation of the NovAtel receiver by providing a series of windows whose functionality is explained in this section. A help file is included with GPSolution. To access the file, select Contents from the Help menu.

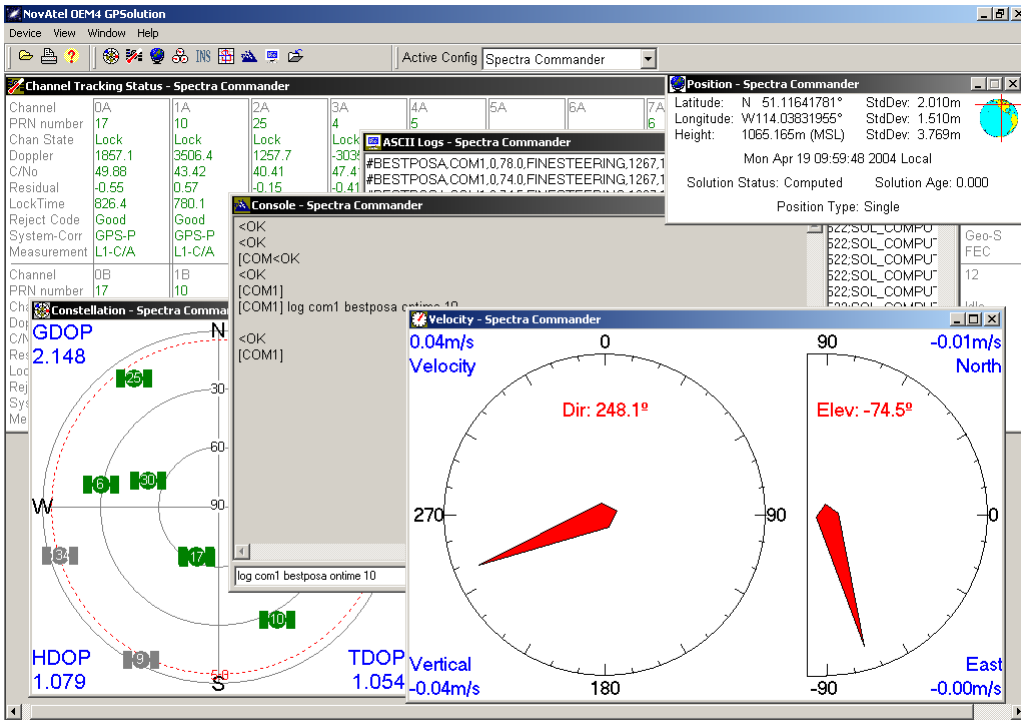

Most windows have a popup menu accessible by right clicking on the window with the mouse. They provide a way to customize the window by changing the font or to print the window contents. Some of the windows have access to the Options dialog which contains further settings for certain windows.

- **Constellation Window:** The Constellation window displays the location of the satellites that are being tracked. The PRN numbers are displayed in the center of each satellite symbol.

Double clicking on the satellite symbol will cause a popup window to appear displaying the information about that PRN such as azimuth, elevation, residual, Doppler, carrier/noise, locktime, pseudorange, tracking state and reject code.

The concentric circles on the display represent the horizon at 0 degrees (outer edge of the plot) and the zenith, directly overhead at 90 degrees (center of the plot).

The DOP values of the position are shown in the four corners of the window.

- **Channel Tracking Status Window:** This window provides the user with the tracking status of the satellites in view. Information, such as channel, PRN, channel state, Doppler, carrier / noise, residual, locktime, reject-code, satellite system and measurement is displayed for all satellites being tracked.

The popup dialog box for this window provides access to the Options dialog box that allows the user to select which fields are displayed in the Channel Tracking Status window.

- **Position Window:** This window displays the receiver's current Latitude, Longitude and Height along with the standard deviations of each.

The time and date as received from the receiver are displayed.

The popup dialog box for this window provides access to the “Options” dialog box that allows the user to select what units are displayed for position, velocity, height, time and distance.

- **Velocity and Heading Window:** This window displays direction of travel in the left dial and climb in the right dial.

The overall velocity is displayed in the top left hand corner, the vertical component of velocity is displayed in the lower left hand corner, the north and east components of velocity are displayed in the top right and bottom right corners of the window respectively.

The popup dialog box for this window provides access to the “Options” dialog box that allows the user to select velocity filter settings. The user can enable velocity filtering and use a slider control to select a velocity, below which, the receiver will be considered stationary. This setting is useful for preventing GPS signal effects from making a stationary object appear to move.

- **INS Window:** If applicable, please refer to your SPAN User Manual for more on INS.
- **Plan Window:** This window displays real-time graphic plotting of the current position of the GPS antenna as computed by the GPS receiver. The latitude and longitude shown at the top of the window is the position of the receiver antenna when the window was opened or after the reset plan button was pressed. The receiver’s position is plotted relative to this initial position.
- **Console Window:** This window allows the user to communicate directly to the receiver through the serial port. It is essentially a terminal emulator with added receiver functionality. Commands can be issued to the receiver via the command editor (at the bottom of the window) and sent by pressing the Enter button or simply pressing <Enter> on the keyboard. The command editor has recall functionality similar to DosKey whereby pressing the up arrow on the keyboard will move backward through the previously issued commands and pressing the down arrow will move forward through the previously issued commands. This allows the user to scroll through previously issued commands and then press the <Enter> key to issue that command again.

Feedback from the receiver is displayed in the ASCII Messages or Console window depending on the format of the message (ASCII or Abbreviated ASCII respectively).

WARNING: **Ensure all other windows are closed in GPSolution when entering the SAVECONFIG command in the Console window.**

If you find that GPSolution is unable to locate your OEM4 family receiver, it may be that you have previously used the SAVECONFIG command. In this case, try using a different COM port to communicate to the receiver. Once communication has been established, issue a FRESET STANDARD command. You should now be able to use your original communication port again.

- **Logging Control Window:** This window provides a graphical interface for configuring data logging that includes initiating data logging to a file, initiating logging to the receiver's serial ports, specifying a time window for data logging, stopping logging and editing log settings.

WARNING: **Ensure the Power Settings on your PC are not set to go into Hibernate or Standby modes. Data will be lost if one of these modes occurs during a logging session. Refer to GPSolution’s online Help for more information.**

- **ASCII Messages Window:** This window displays ASCII formatted NovAtel logs.

7.3 Convert

Convert is a 32-bit Windows application and is shown in *Figure 25*. Convert will accept GPS file formats and convert them to ASCII, Binary or Rinex format. The application also allows the user to screen out particular logs by selecting the desired logs from the list of available logs. This feature is useful for screening particular logs out of large data files in either ASCII or Binary formats.

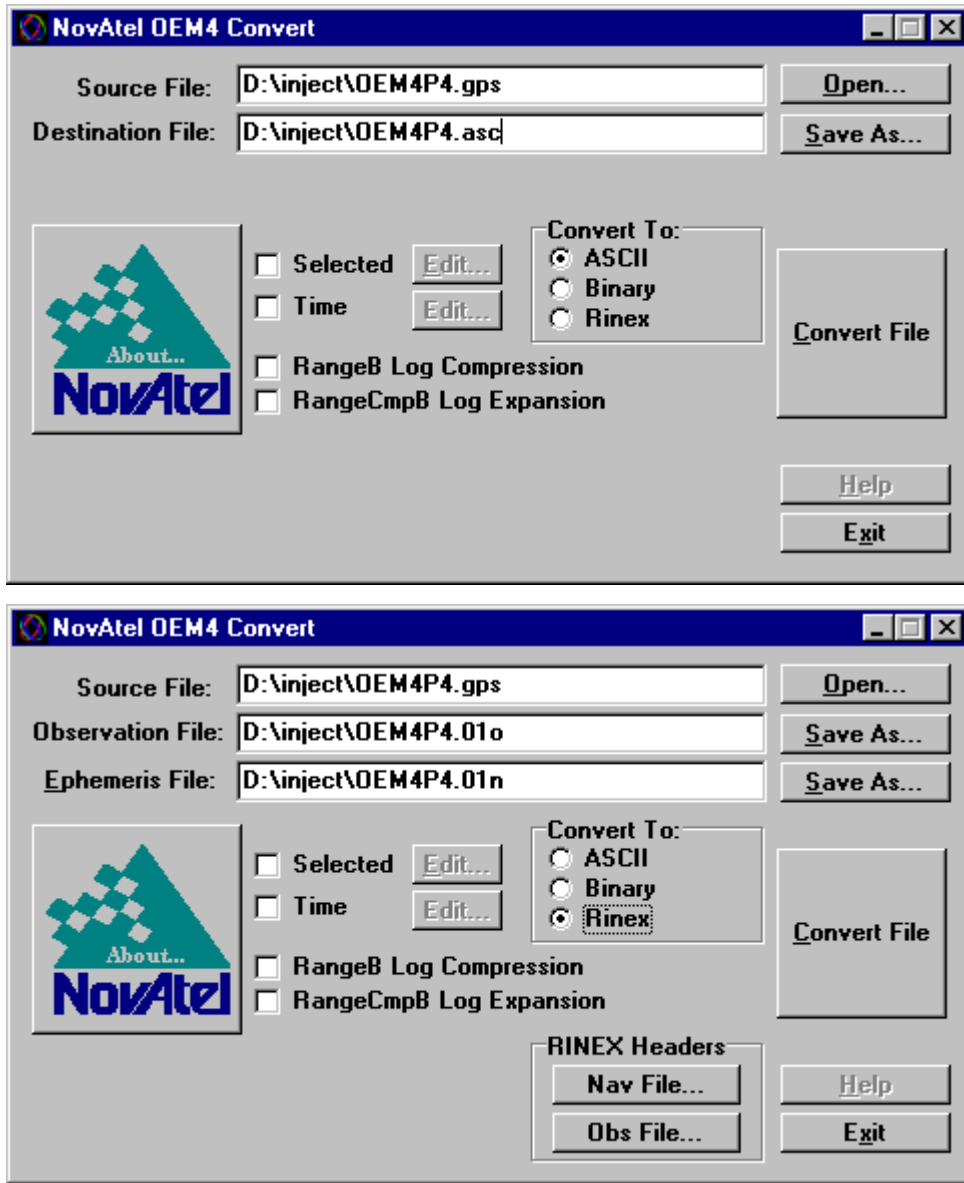

Figure 25: Convert Screen Examples

7.3.1 Rinex Format

The Receiver-Independent Exchange (RINEX¹) format is a broadly-accepted, receiver-independent format for storing GPS data. It features a non-proprietary ASCII file format that can be used to combine or process data generated by receivers made by different manufacturers.

The Convert4 utility can be used to produce RINEX files from NovAtel receiver data files.

-
- ☒ Although RINEX is intended to be a receiver-independent format, there are many optional records and fields. Please keep this in mind when combining NovAtel and non-NovAtel RINEX data.
-

When converting to RINEX, two files are produced - a RINEX observation file and a RINEX navigation file. The default names of these two files conforms to the RINEX Version 2.10 recommended naming convention of ssssddf.yyt, where:

ssss	4 character station name - Convert4 uses the first four characters of the <infile> parameter as the station ID
ddd	day of year
f	file sequence number within the day - Convert4 sets this to zero
t	file type: o for the observation and n for the navigation file

Selecting the RINEX field, see *Figure 25, Convert Screen Examples on Page 92*, in the Convert To section causes the:

1. *Destination File:* field to be replaced by the *Observation File:* and *Ephemeris File:* fields. Note that Observation File refers to the RINEX OBS file while Ephemeris File refers to the RINEX NAV file.
2. *RINEX Headers* buttons to appear allowing you to supply additional information that appears in the header records of the RINEX output files (for example, Company Name, Marker Name and Marker Number).

For best results, the NovAtel receiver input data file should contain the logs as in *Table 18 on Page 94*.

1. For further information on RINEX Version 2.10 file descriptions, you may wish to consult the U.S. National Geodetic Survey website at <http://www.ngs.noaa.gov/CORS/Rinex2.html>.

Table 18: NovAtel Logs for Rinex Conversion

NovAtel OEM4 Family Log	Recommended Trigger
RANGEA/B, or RANGECMPA/B	ontime 15
BESTPOSA/B, or PSRPOSA/B, or RTKPOSA/B, or MARKPOSA/B	once
IONUTCA/B	onchanged
RAWEPHEMA/B	onchanged
VERSION ^a	once
SITEDEFA/B ^b	once

- a. Information from this log overrides data entered into the Receiver Number and Receiver Version fields using the OBS file button of the RINEX Headers section, see *Figure 25 on Page 92*
- b. Available on DL-4plus receivers, refer to the *DL-4plus User Manual*. Information from this log overrides data entered into the Marker Name, Marker Number, Antenna Type and Antenna Delta H fields using the OBS file button of the RINEX Headers section

7.3.2 Convert Command Line Switches

Convert4 supports several command-line switches to facilitate batch processing. To access its Command Line Arguments window, open a command prompt window (select Accessories | Command Prompt from the Start menu). Change directory (cd) to the directory on your hard drive that Convert4 is stored. Type the following:

```
convert4 -h
```

The Convert4 Command Line Arguments window appears as shown in *Figure 26 on Page 95*.

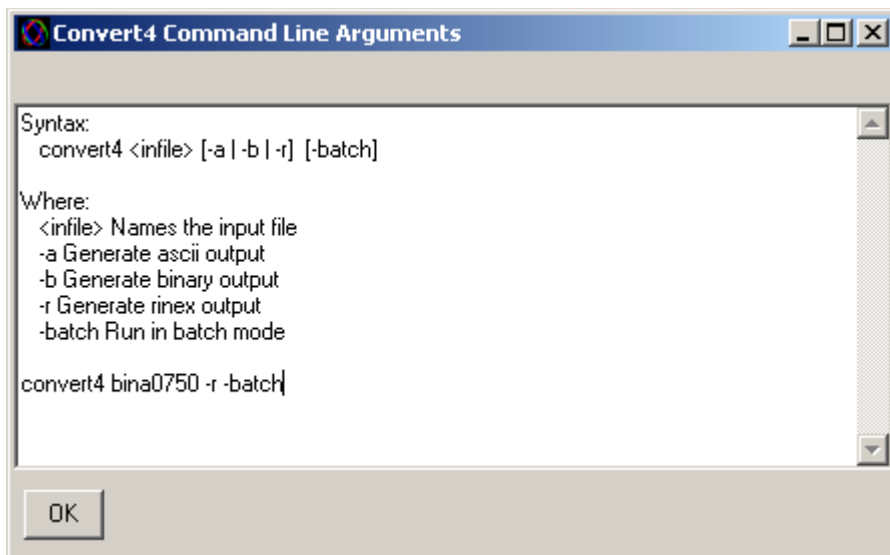

Figure 26: Convert Command Line Arguments

The name of the output file is the same as the input file when converting to ASCII or binary formats. The file extension, however, is altered to indicate the format of the data:

- *.asc for ASCII
- *.bin for binary

When converting to RINEX, the output files are named according to the RINEX Version 2.10 naming convention, see *Section 7.3.1, Rinex Format on Page 93*.

The -batch arguments suppress the window display and convert the specified file automatically.

-
- When converting to RINEX in batch mode, the navigation and observation file header information from the most recent interactive Convert session is used.
-

7.4 USB Drivers Installation

The NovAtel USB PC Driver Kit contains the following:

ngpsser.sys	This driver provides a virtual serial port for each USB port of the receiver.
ngpsusb.sys	This driver connects the virtual serial ports to the USB stack.
novatelusb.exe	This utility allows you to control which Windows COM ports are assigned to each USB port of the receiver. This utility can also be used to uninstall the drivers when newer versions are available. During installation, a shortcut is added to the Start Menu under Programs/OEM4 PC Software/NovAtel USB Configuration Utility.

-
- These drivers have not been certified by Microsoft's Windows Hardware Quality Lab (WHQL). Depending on your computer's Driver Signing Policy, Windows may refuse to install this driver or may display a warning. See *Section 7.4.3, Windows Driver Signing on Page 97* for details.
-

7.4.1 Windows XP Installation

If upgrading drivers, uninstall older versions using the NovAtel USB Configuration tool located in the Start Menu under Program Files | OEM4 PC Software.

After connecting the NovAtel GPS receiver to a USB port on the PC, the Found New Hardware wizard appears. Click on Next.

1. Select the *Install from a list or specific location (Advanced)* field and click on *Next*.
2. Clear the *Search removable media* check box, select the *Include this location in the search:* field and Browse to the newest USB driver install directory on the supplied OEM4 family CD.
3. Click on Next.
4. Click on Finish to complete the driver installation.

After installing the NovAtel USB driver, Windows detects the OEM4 receiver's new virtual COM ports and begins to initialize them. As each port is detected, the Found New Hardware wizard appears.

Complete the following steps for each port:

1. Select the *Install the software automatically* field (recommended) and click on Next.
2. Click on Finish.

Installation is complete when no more dialogs appear. The new COM ports corresponding to the receiver's USB1, USB2, and USB3 ports are numbered sequentially following the existing ports in the PC, and are ready to use with any existing application that communicates with the receiver's COM ports.

-
- ☒ The assignment of COM port numbers is tied to the USB port on the PC. This allows you to switch receivers without Windows assigning new COM ports. However, if you connect the receiver to a different USB port, Windows detects the receiver's presence on that USB port and assigns three new COM port numbers.
-

7.4.2 *Windows 2000 Installation*

If upgrading drivers, uninstall older version using NovAtel USB Configuration tool located in the Start Menu under Program Files | OEM4 PC Software.

After connecting the NovAtel GPS receiver to a USB port on the PC, the Found New Hardware wizard appears. Click on Next.

1. Select the Search for a suitable driver for my device field and click on Next.
2. Select the Specify a location field and click on Next.
3. Specify the location using the browse button, for example, on the supplied OEM4 family CD:
USB Drivers\Install
4. Click on OK.
5. Confirm that the driver found is, for example:
\\USB Drivers\Install\ngpsusb.inf
6. Click on Next.
7. Click on Finish to complete the driver installation.

After installing the drivers, Windows detects the NovAtel receiver's new virtual COM ports and begins to initialize them. Installation is complete when no more dialogs appear. The new COM ports corresponding to the receiver's USB1, USB2, and USB3 ports are numbered sequentially following the existing ports in the PC, and are ready to use with any existing application that communicates with the receiver's COM ports.

-
- ☒ The assignment of COM port numbers is tied to the USB port on the PC. This allows you to switch receivers without Windows assigning new COM ports. However, if you connect the receiver to a different USB port, Windows detects the receiver's presence on that USB port and assign three new COM port numbers.
-

7.4.3 *Windows Driver Signing*

Depending on how your administrator has configured your computer, Windows 2000 and Windows

XP either ignore device drivers that are not digitally signed, display a warning when they detect device drivers that are not digitally signed (the default), or prevent you from installing device drivers without digital signatures.

Since the current version of NovAtel USB drivers are not digitally signed, the computer's policy must be either Ignore or Warn to enable the drivers to be installed.

To change the Driver Signing Policy on your computer:

1. Double-click on System in the Control Panel.
2. Select the Hardware tab.
3. Click on the Driver Signing button
4. Select either Ignore or Warn in the File signature verification box.
5. Click on OK to accept the new policy.
6. Click on OK again to close the System Properties dialog.
7. Unplug the NovAtel receiver USB cable, plug it back in and follow the installation instructions described above in either *Windows XP Installation* or *Windows 2000 Installation* starting on Page 96.

7.5 Firmware Upgrades & Updates

The receiver stores its program firmware in non-volatile memory, which allows you to perform firmware upgrades and updates without having to return the receiver to the distributor. New firmware can be transferred to the receiver through COM1, and the unit will immediately be ready for operation at a higher level of performance.

The first step in upgrading your receiver is to contact your local NovAtel dealer. Your dealer will assist you in selecting the best upgrade option that suits your specific GPS needs. If your needs are still unresolved after seeing your dealer then you can contact NovAtel directly through any of the methods described in the Customer Service section, *see Page 12*, at the beginning of this manual.

When you call, be sure to have available your receiver model number, serial number, and program revision level. This information can be found by issuing the LOG VERSION command at the port prompt.

After establishing which new model/revision level would best suit your needs, and having described the terms and conditions, you will be issued an authorization code (auth-code). The auth-code is required to unlock the new features according to your authorized upgrade/update model type.

There are two procedures to choose from, depending on the type of upgrade/update you require:

1. If you are upgrading to a higher performance model at the same firmware revision level (for example, upgrading from an OEM4 - 3151R rev. 1.000, to an OEM4 - RT-2 rev. 1.000), you can use the AUTH command with the issued auth-code.
2. If you are updating to a higher firmware revision level (for example, updating an OEM4 - RT-2 rev. 1.000 to OEM4 - RT-2 rev. 1.010), you will need to transfer new program firmware to the OEM4 family receiver using the WinLoad utility program. As WinLoad and the update file are generally provided in a compressed file format, you will also be given a decompression password. WinLoad and the update files can be found on NovAtel's FTP site at <http://www.novatel.com>, or can be sent to you on disk or by e-mail.

Your local NovAtel dealer will provide you with all the information that you require to update or upgrade your receiver.

7.5.1 Upgrading Using the AUTH Command

The AUTH command is a special input command which authorizes the enabling or unlocking of the various model features. Use this command when upgrading to a higher performance OEM4 family model available within the same revision level as your current model (for example, upgrading from an OEM4-3151R, to an OEM4-RT2). This command only functions in conjunction with a valid auth-code assigned by Customer Service.

The upgrade can be performed directly from GPSolution's Command Line Screen, or from any other communications program. The procedure is as follows:

- 1) Power-up the OEM4 family receiver and establish communications over a serial port (see *Chapter 4, Operation on Page 41*)
- 2) Issue the LOG VERSION command to verify the current firmware model number, revision level, and serial number.
- 3) Issue the AUTH command, followed by the auth-code and model type. The syntax is as follows:

Syntax:

```
auth auth-code
```

where auth is a special command which allows program model upgrades

auth-code is the upgrade authorization code, expressed as hhhh,hhh,hhh,hhh,hhh,model# where the h characters are an ASCII hexadecimal code, and the model# would be ASCII text

Example:

```
auth 17cb,29af,3d74,01ec,fd34,oem4rt2
```

Once the AUTH command has been executed, the OEM4 family receiver will reboot itself. Issuing the LOG VERSION command will confirm the new upgrade model type and version number.

If communicating using GPSolution, the communication path needs to be closed and re-opened using the Device menu.

7.5.2 Updating Using the WinLoad Utility

WinLoad is required (instead of the AUTH command) when updating previously released firmware with a newer version of program and model firmware (for example, updating an OEM4 Standard rev. 1.000 to OEM4 Standard rev. 1.010). WinLoad is a Windows utility program designed to facilitate program and model updates. Once WinLoad is installed and running, it will allow you to select a host PC serial port, bit rate, directory path, and file name of the new program firmware to be transferred to the OEM4 family receiver via its COM1, COM2 or COM3 port. The port chosen must have an RS232 interface to the PC.

7.5.2.1 Transferring Firmware Files

To proceed with your program update, you must first acquire the latest firmware revision. You will need a file with a name such as OEMXXXX.EXE (where XXXX is the firmware revision level). This file is available from NovAtel's FTP site (<http://www.novatel.com>), or via e-mail (support@novatel.ca). If transferring is not possible, the file can be mailed to you on floppy disk. For more information on how to contact NovAtel Customer Service please see *Page 12* at the beginning of this manual.

You will need at least 1 MB of available space on your hard drive. For convenience, you may wish to copy this file to a GPS sub-directory (for example, C:\GPS\LOADER).

The file is available in a compressed format with password protection; Customer Service will provide you with the required password. After copying the file to your computer, it must be decompressed. The syntax for decompression is as follows:

Syntax:

```
[filename] [password]
```

where filename is the name of the compressed file (but not including the .EXE extension)

password is the password required to allow decompression

Example:

```
oem1001 12345678
```

A windows-based dialog box is provided for password entry.

The self-extracting archive will then generate the following files:

WinLoad.exe	WinLoad utility program
HowTo.txt	Instructions on how to use the WinLoad utility
WhatsNew.txt	Information on the changes made in the firmware since the last revision
XXXX.hex	Firmware version update file, where XXXX = program version level (for example, 1001.hex)

7.5.2.2 Using the WinLoad Utility

WinLoad is a windows based program used to download firmware to OEM4 family GPSCards. The main screen is shown in *Figure 27*.

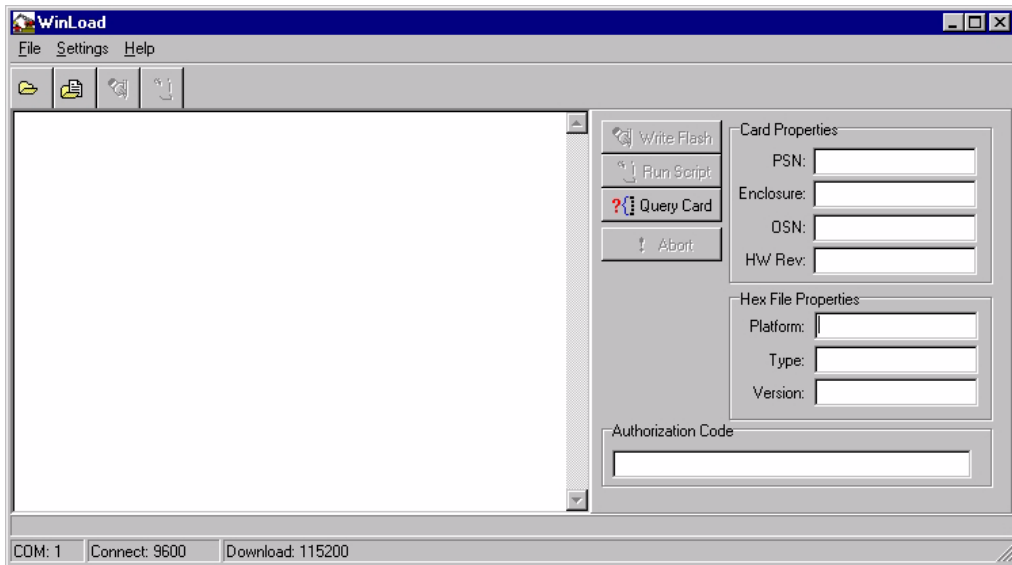

Figure 27: Main Screen of WinLoad

If you are running WinLoad for the first time you will need to make sure the file and communications settings are correct.

7.5.2.2.1 Open a File to Download

From the file menu choose Open. Use the Open dialog to browse for your file, see *Figure 28*, *WinLoad's Open Dialog on Page 102*.

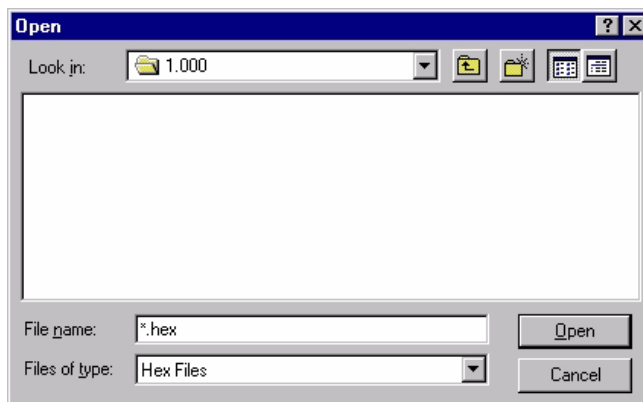

Figure 28: WinLoad's Open Dialog

Once you have selected your file, the name should appear in the main display area and in the title bar, see *Figure 29* below.

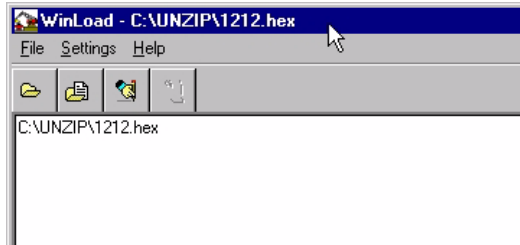

Figure 29: Open File in WinLoad

7.5.2.2.2 Communications Settings

To set the communications port and baud rate, select COM Settings from the Settings menu. Choose the port on your PC from the Com Port dropdown list and the baud rate from the Download Baudrate dropdown list. The baud rate should be as high as possible (the default of 115200 is preferred).

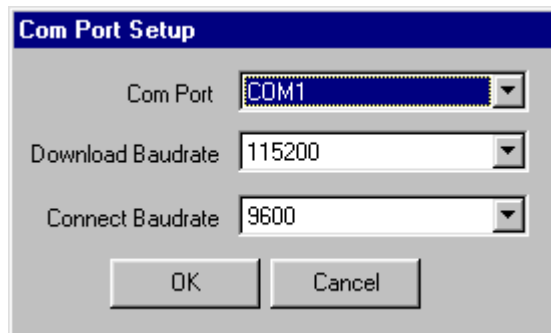

Figure 30: COM Port Setup

7.5.2.2.3 Downloading firmware

To download firmware follow these steps:

1. Set up the communications port as described in *Communications Settings above*.
2. Select the file to download, see *Open a File to Download on Page 102*.
3. Make sure the file path and file name are displayed in main display area, see *Figure 29, Open File in WinLoad*.
4. Click on the Write Flash button to download the firmware.
5. Power down and then power up the receiver when "Searching for card" appears in the main display, see *Figure 31*.

Searching for card...timeout in: 13 secs

Figure 31: Searching for Card

- When the Authorization Code dialog opens, see *Figure 32*, enter the auth code and select OK

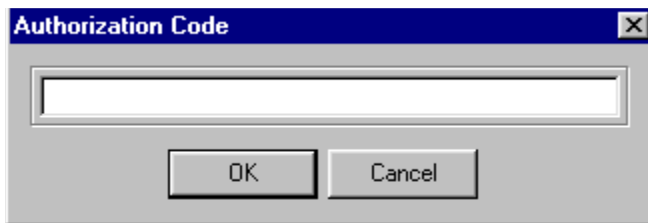

Figure 32: Authorization Code Dialog

- The receiver should finish downloading and reset. The process is complete when "Done." is displayed in the main display area, see *Figure 33*.

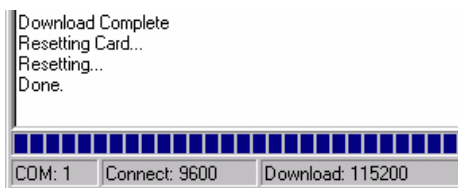

Figure 33: Update Process Complete

- Close WinLoad.

This completes the procedure required to update an OEM4 family receiver.

8.1 Overview

The built in test monitors system performance and status to ensure the receiver is operating within its specifications. If an exceptional condition is detected, the user is informed through one or more indicators. The receiver status system is used to configure and monitor these indicators:

1. Receiver status word (included in the header of every message)
2. ERROR strobe signal (see *Table 7 on Page 37*)
3. RXSTATUSEVENT log
4. RXSTATUS log
5. Status LED

In normal operation the error strobe is driven low and the status LED on the receiver flashes green. When an unusual and non-fatal event occurs (for example, there is no valid position solution), a bit is set in the receiver status word. Receiver operation continues normally, the error strobe remains off, and the LED continues to flash green. When the event ends (for example, when there is a valid position solution), the bit in the receiver status word is cleared.

When a fatal event occurs (for example, in the event of a receiver hardware failure), a bit is set in the receiver error word, part of the RXSTATUS log, to indicate the cause of the problem. Bit 0 is set in the receiver status word to show that an error occurred, the error strobe is driven high, and the LED flashes red and yellow showing an error code. An RXSTATUSEVENT log is generated on all ports to show the cause of the error. Receiver tracking is disabled at this point but command and log processing continues to allow you to diagnose the error. Even if the source of the error is corrected at this point, the receiver must be reset to resume normal operation.

The above two paragraphs describe factory default behavior. Customization is possible to better suit an individual application. RXSTATUSEVENT logs can be disabled completely using the UNLOG command. RXSTATUSEVENT logs can be generated when a receiver status bit is set or cleared by using the STATUSCONFIG SET and STATUSCONFIG CLEAR commands. Bits in the receiver status words can also be promoted to be treated just like error bits using the STATUSCONFIG PRIORITY command.

8.2 Receiver Status Word

The receiver status word indicates the current status of the receiver. This word is found in the header of all logs. In addition the receiver status word is configurable.

The receiver gives the user the ability to determine the importance of the status bits. This is done using the priority masks. In the case of the Receiver Status, setting a bit in the priority mask will cause the condition to trigger an error. This will cause the receiver to idle all channels, turn off the antenna, and disable the RF hardware, the same as if a bit in the Receiver Error word is set. Setting a bit in an Auxiliary Status priority mask will cause that condition to set the bit in the Receiver Status word corresponding to that Auxiliary Status.

The STATUS CONFIG command is used to configure the various status mask fields in the

RXSTATUS event log. These masks allow you to modify whether various status fields generate errors or event messages when they are set or cleared. This is meant to allow you to customize the operation of your OEM4 family receiver for your specific needs.

Refer to the RXSTATUS log and the STATUSCONFIG command in *Volume 2* of this manual set for more detailed descriptions of these messages.

8.3 Error Strobe Signal

The error strobe signal is one of the I/O strobes and is driven low when the receiver is operating normally. When the receiver is in the error state and tracking is disabled, the error strobe is driven high. This can be caused by a fatal error or by an unusual receiver status indication that the user has promoted to be treated like a fatal error. Once on, the error status will remain high until the cause of the error is corrected and the receiver is reset. See *Table 7* on *Page 37* for the pin number descriptions.

8.4 RXSTATUSEVENT Log

The RXSTATUSEVENT log is used to output event messages as indicated in the RXSTATUS log.

On startup, the OEM4 family receiver is set to log the RXSTATUSEVENTA log ONNEW on all ports. You can remove this message by using the UNLOG command.

Refer to the RXSTATUSEVENT log in *Volume 2* of this manual set for a more detailed description of this log.

8.5 Receiver Status Log

8.5.1 Overview

The Receiver Status log (RXSTATUS) provides information on the current system status and configuration in a series of hexadecimal words.

The status word is the third field after the header, as shown in the example below.

```

<RXSTATUS COM2 0 71.0 FINE 1209 239039.799 00000022 b8d0 754
< 00000022 4
< 00040028 00000000 00000000 00000000
< 00400005 00000008 00000000 00000000
< 00000000 00000000 00000000 00000000
< 00000000 00000000 00000000 00000000

```

Receiver Status Word

Figure 34: Location of Receiver Status Word

Each bit in the status word indicates the status of a specific condition or function of the receiver. If the status word is 00000000, the receiver is operating normally. The numbering of the bits is shown in Figure 35 below.

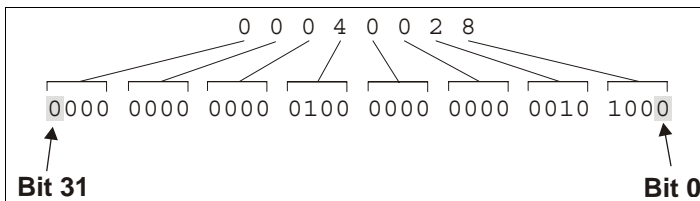

Figure 35: Reading the Bits in the Receiver Status Word

The format of the log is described in *Volume 2* of this manual set. If the receiver status word indicates a problem, please also see *Section 9.1, Examining the RXSTATUS Log on Page 113*.

8.5.2 Error Word

The error field contains a 32 bit word. Each bit in the word is used to indicate an error condition. Error conditions may result in damage to the hardware or erroneous data, so the receiver is put into an error state. If any bit in the error word is set, the receiver will set the error strobe line, flash the error code on the status LED, broadcast the RXSTATUSEVENT log on all ports (unless the user has unlogged it), idle all channels, turn off the antenna, and disable the RF hardware. The only way to get out of the error state is to reset the receiver.

It is also possible to have status conditions trigger event messages to be generated by the receiver. Receiver Error words automatically generate event messages. These event messages are output in RXSTATUSEVENT logs (see also *Section 8.5.6, Set and Clear Mask for all Status Code Arrays on Page 109*).

The error word is the first field after the log header in the RXSTATUS log, as shown in the example below, or the third from last field in the header of every log.

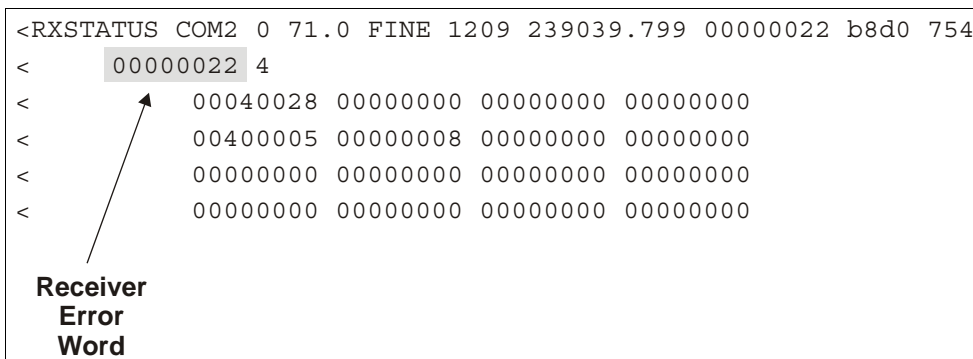

Figure 36: Location of Receiver Error Word

The numbering of the bits is shown in *Figure 37 on Page 108*.

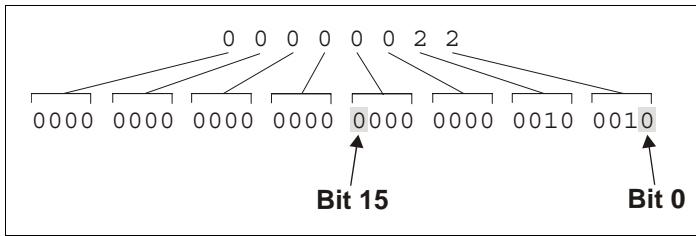

Figure 37: Reading the Bits in the Receiver Error Word

Refer to the RXSTATUS and the RXSTATUSEVENT logs in *Volume 2* of this manual set for more detailed descriptions of these logs. If the receiver error word indicates an error, please also see *Section 9.1, Table 20, Resolving a Receiver Error Word on Page 113*.

8.5.3 Status Code Arrays

There are 3 status code arrays – the receiver status word, the auxiliary 1 status and the auxiliary 2 status. Each status code array consists of 4, 32 bit words (the status word, a priority mask, a set mask and a clear mask). The status word is similar to the error word, with each of the 32 bits indicating a condition. The mask words are used to modify the behavior caused by a change in one of the bits in the associated status words. Each bit in any of the masks operates on the bit in the same position in the status word. For example setting bit 3 in the priority mask changes the priority of bit 3 in the status word.

8.5.4 Receiver Status Code

The receiver status word is included in the header of all logs. It has 32 bits, which indicate certain receiver conditions. If any of these conditions occur, a bit in the status word is set. Unlike the error word bits the receiver will continue to operate, unless the priority mask for the bit has been set. The priority mask bit will change that of the receiver status word into an error bit. Anything that would result from an error bit becoming active would also occur if a receiver status and its associated priority mask bits are set.

8.5.5 Auxiliary Status Codes

The auxiliary status codes are only seen in the RXSTATUS log. The two bits representing the auxiliary status codes give indication about the receiver state for information only. The bits typically do not cause degradation of the receiver performance. The priority mask for the auxiliary codes does not put the receiver into an error state. Setting a bit in the auxiliary priority mask results in the corresponding bit in the receiver status code to be set if any masked auxiliary bit is set. Bit 31 of the receiver status word indicates the condition of all masked bits in the auxiliary 1 status word. Likewise, bit 32 of the receiver status word corresponds to the auxiliary 2 status word.

Refer also to the RXSTATUS log in *Volume 2* of this manual set for a more detailed descriptions of this log.

8.5.6 Set and Clear Mask for all Status Code Arrays

The other two mask words in the status code arrays operate on the associated status word in the same way. These mask words are used to configure which bits in the status word will result in the broadcast of the RXSTATUSEVENT log. The set mask is used to turn logging on temporarily while the bit changes from the 0 to 1 state. The clear mask is used to turn logging on temporarily while the bit changes from a 1 to a 0 state. Note the error word does not have any associated mask words. Any bit set in the error word will result in the broadcast of the RXSTATUSEVENT log (unless unlogged).

Refer also to the RXSTATUSEVENT log in *Volume 2* of this manual set for a more detailed description.

8.6 Status LED

The diagnostic LED provided on the OEM4 family receivers blinks green on and off at approximately 1 Hz to indicate normal operation.

Error bits and status bits that have been priority masked, as errors, will cause the LED to flash a code in a binary sequence. The binary sequence will be a 6 flash (0.5 second on and 0.25 second off per flash) sequence followed by a 1 second delay. The sequence will repeat indefinitely. If there is more than one error or status present, the lowest number will be output. The codes are ordered to have the highest priority condition output first.

The first flash in the 6 flash sequence indicates if the code that follows is an error bit or a status bit. Error bits will flash red and status bits will flash yellow. The next 5 flashes will be the binary number of the code (most significant bit first). A red flash indicates a one and a yellow flash indicates a zero. For example, for an error bit 6, the binary number is 00110 so the output sequence would be:

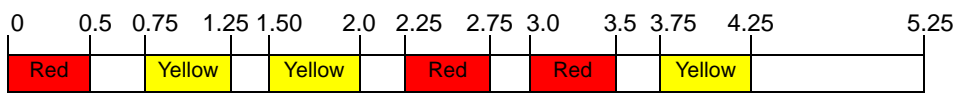

followed by a 1 second delay. The sequence repeats indefinitely until the receiver is reset.

In the example on *Page 110*, the first flash in the sequence is red, which means that a bit is set in the receiver error word. The next five flashes give a binary value of 00111. Converting this value to decimal results in a value of 7. Therefore, bit 7 of the receiver error word is set, indicating there is a problem with the supply voltage of the receiver’s power circuitry.

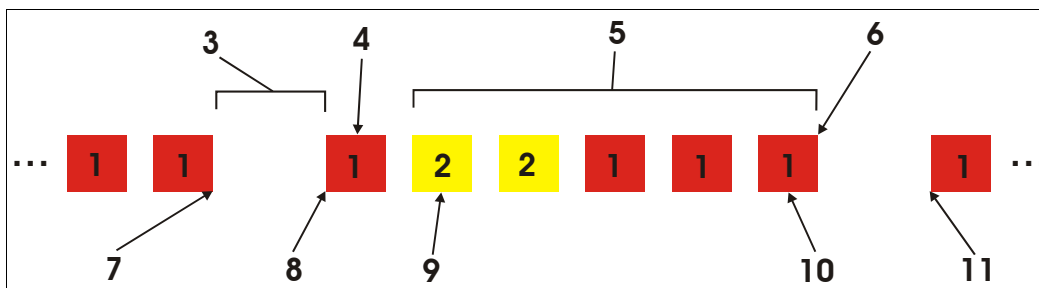

Figure 38: Status LED Flash Sequence Example

Reference	Description
1	Red
2	Yellow
3	1 Second Pause
4	Word Identifier Flash
5	Bit Identifier Flashes
6	End of Sequence
7	End of Previous Sequence
8	Beginning of Sequence
9	Most Significant Bit of Binary Value
10	Least Significant Bit of Binary Value
11	Start of Next Sequence

For a complete hexadecimal to binary conversion list, refer to the *Unit Conversion* section of the *GPS+ Reference Manual*. Refer also to the RXSTATUS log, and its tables, in *Volume 2* of this manual set for more details on this log and receiver error status.

When your receiver appears not to be working properly, often there are simple ways to diagnose and resolve the problem. In many cases, the issue can be resolved within a few minutes, avoiding the hassle and loss of productivity that results from having to return your receiver for repair. This chapter is designed to assist you in troubleshooting problems that occur and includes navigational instructions to bring you to the part of this manual that details resolutions to aid your receiver's operation.

If you are unsure of the symptoms or if the symptoms do not match any of those listed, use the RXSTATUS log to check the receiver status and error words. See *Section 9.1, Examining the RXSTATUS Log, Page 113*.

If the problem is not resolved after using this troubleshooting guide, contact Customer Service, see *Page 12*.

Table 19: Troubleshooting based on Symptoms

Symptom	Related Section
The receiver is not properly powered	Check for and switch a faulty power cable. See <i>Section 3.1.3, Power Supply Requirements, Page 29</i> and <i>Section 3.3.3, Status Indicators, Page 38</i> .
The receiver cannot establish communication	Check for and switch faulty serial cables and ports. See <i>Section 3.3.3, Status Indicators, Page 38</i> and <i>Section 8.6, Status LED, Page 109</i> . Refer also to the COMCONFIG log in <i>Volume 2</i> of this manual set.
The receiver is not tracking satellites	Check for and replace a faulty antenna cable. See <i>Section 3.1.1, Selecting a GPS Antenna, Page 28</i> , <i>Section 3.1.2, Choosing a Coaxial Cable, Page 28</i> , <i>Section 3.2.3, Connecting the Antenna to the Receiver, Page 34</i> , <i>Section 3.3.5, External Antenna LNA Power (OEM4-G2 Only), Page 40</i> and refer to the <i>Time to First Fix and Satellite Acquisition</i> section of the <i>GPS+ Reference Manual</i> .
No data is being logged	See <i>Section 3.3.3, Status Indicators, Page 38</i> , and <i>Section 4.1, Communications with the Receiver, Page 42</i> .
Random data is being output by the receiver	See <i>Section 3.3.3, Status Indicators, Page 38</i> . Refer also to the COMCONFIG log and FRESET command in <i>Volume 2</i> of this manual set.

Continued on Page 112

A command is not accepted by the receiver	See <i>Section 4.1, Communications with the Receiver, Page 42</i> and refer to the FRESET command in <i>Volume 2</i> of this manual set.
Differential mode is not working properly	See <i>Section 4.3, Transmitting and Receiving Corrections, Page 45</i> and refer to the COMCONFIG log in <i>Volume 2</i> of this manual set.
There appears to be a problem with the receiver's memory	Refer to the NVMRESTORE command in <i>Volume 2</i> of this manual set.
An environmental or memory failure. The receiver temperature is out of acceptable range or the internal thermometer is not working	See the ENVIRONMENTAL sections in the tables of <i>Appendix A, Technical Specifications</i> starting on <i>Page 118</i> .
Overload and overrun problems. Either the CPU or port buffers are overloaded	Reduce the amount of logging. See also <i>Section 4.1.1, Serial Port Default Settings, Page 42</i> .
The receiver is indicating that an invalid authorization code has been used	Refer to the Version log in <i>Volume 2</i> of this manual set.
The receiver is being affected by jamming	Move the receiver away from any possible jamming sources.
The receiver's automatic gain control (AGC) is not working properly	See <i>Section 3.1.2, Choosing a Coaxial Cable, Page 28</i> and the jamming symptom in this table.

9.1 Examining the RXSTATUS Log

The RXSTATUS log provides detailed status information about your receiver and can be used to diagnose problems. Please refer to *Volume 2* of this manual set for details on this log and on how to read the receiver error word and status word. *Tables 20 and 21 on pages 113 to 115* give you actions to take when your receiver has an error flag in either of these words.

Table 20: Resolving a Receiver Error Word

Bit Set	Action to Resolve
0	Issue a FRESET command, refer to <i>Volume 2</i> of this manual set.
1	Issue a FRESET command, refer to <i>Volume 2</i> of this manual set.
2	Issue a FRESET command, refer to <i>Volume 2</i> of this manual set.
4	Contact Customer Service as described on <i>Page 12</i> .
5	Check the VERSION log, refer to <i>Volume 2</i> of this manual set.
6	Issue a FRESET command, refer to <i>Volume 2</i> of this manual set.
7	See <i>Section 3.1.3, Power Supply Requirements, Page 29</i> .
8	Issue a NVMRESTORE command, refer to <i>Volume 2</i> of this manual set.
9	Check temperature ranges in the ENVIRONMENTAL table sections of <i>Appendix A, Technical Specifications</i> starting on <i>Page 118</i> .
10	Contact Customer Service as described on <i>Page 12</i> .
11	
12	
13	
14	
15	Move the receiver away from any possible jamming sources.

Table 21: Resolving an Error in the Receiver Status Word

Bit Set	Action to Resolve
0	Check the Error Word in the RXSTATUS log. See also <i>Table 20, Resolving a Receiver Error Word</i> , on Page 113.
1	Check temperature ranges in the ENVIRONMENTAL table sections of <i>Appendix A, Technical Specifications</i> starting on Page 118.
2	See <i>Section 3.1.3, Power Supply Requirements</i> , Page 29.
3	See <i>Section 3.1.1, Selecting a GPS Antenna</i> , Page 28, <i>Section 3.1.2, Choosing a Coaxial Cable</i> , Page 28, <i>Section 3.2.3, Connecting the Antenna to the Receiver</i> , Page 34, <i>Section 3.3.5, External Antenna LNA Power (OEM4-G2 Only)</i> , Page 40 and refer to the <i>Time to First Fix and Satellite Acquisition</i> section of the <i>GPS+ Reference Manual</i> .
4	
5	
6	
7	See <i>Section 4.1.1, Serial Port Default Settings</i> , Page 42.
8	
9	
10	
11	
14	Move the receiver away from any possible jamming sources.
15	See <i>Section 3.1.2, Choosing a Coaxial Cable</i> , Page 28 and move the receiver away from any possible jamming sources.
16	Move the receiver away from any possible jamming sources.
17	See <i>Section 3.1.2, Choosing a Coaxial Cable</i> , Page 28 and move the receiver away from any possible jamming sources.
18	None. Once enough time has passed for a valid almanac to be received, this bit will be set to 0. Also, refer to the <i>Time to First Fix and Satellite Acquisition</i> section of the <i>GPS+ Reference Manual</i> .
19	None. This bit only indicates if the receiver has calculated a position yet. Refer to the <i>Time to First Fix and Satellite Acquisition</i> section of the <i>GPS+ Reference Manual</i>
20	None. This bit is simply a status bit indicating if the receiver's position has been manually fixed and does not represent a problem. Refer also to the FIX command in <i>Volume 2</i> of this manual set.

Continued on Page 115

21	None. This bit simply indicates if clock steering has been manually disabled. Refer also to the FRESET command in <i>Volume 2</i> of this manual set.
22	None. This bit only indicates if the clock model is valid. Refer also to the FRESET command in <i>Volume 2</i> of this manual set.
23	None. This bit indicates whether or not the phase-lock-loop is locked when using an external oscillator. Refer also to the FRESET command in <i>Volume 2</i> of this manual set.
30	None. This bit indicates if any bits in the auxiliary 2 status word are set. The auxiliary 2 word simply provides status information and does not provide any new information on problems. Refer also to the FRESET command in <i>Volume 2</i> of this manual set.
31	None. This bit indicates if any bits in the auxiliary 1 status word are set. The auxiliary 1 word simply provides status information and does not provide any new information on problems. Refer also to the FRESET command in <i>Volume 2</i> of this manual set.

A.1 OEM4 Family Receiver Performance

PERFORMANCE (Subject To GPS System Characteristics)

Position Accuracy ^a	Standalone: L1 only 1.8 m CEP L1/L2 1.5 m CEP WAAS: L1 only 1.2 m CEP L1/L2 0.8 m CEP Code Differential 0.45 m CEP RT-20 0.20 m CEP RT-2 0.01 m + 1 ppm CEP OmniSTAR: VBS 1.0 m CEP XP 0.15 m CEP HP 0.10 m CEP Post Processed 5 mm + 1 ppm CEP
Time To First Fix	Hot: 30 s (Almanac and recent ephemeris saved and approximate position) Warm: 40 s (Almanac, approximate position and time, no recent ephemeris) Cold: 50 s (No almanac or ephemeris and no approximate position or time)
Reacquisition	0.5 s L1 (typical) 1.0 s L2 (typical) (Minimum firmware version 2.100 required)
Data Rates	Raw Measurements: 20 Hz Computed Position: 20 Hz OmniSTAR HP Position: 20 Hz
Time Accuracy ^{a b}	20 ns RMS
Velocity Accuracy	0.03 m/s RMS
Measurement Precision	C/A code phase 6 cm RMS L1 carrier phase: Differential 0.75 mm RMS L2 P code 25 cm RMS L2 carrier phase: Differential 2 mm RMS
Dynamics	Vibration 4 g (sustained tracking) Velocity 515 m/s ^c Height 18,288 m ^c

a. Typical values. Performance specifications are subject to GPS system characteristics, U.S. DOD operational degradative ionospheric and tropospheric conditions, satellite geometry, baseline length and multipath effects.

b. Time accuracy does not include biases due to RF or antenna delay.

c. In accordance with export licensing.

A.2 OEM4-G2L GPSCard

PHYSICAL

Size	60mm x 100mm x 12.8mm with connectors
Weight	56 grams

MECHANICAL DRAWINGS

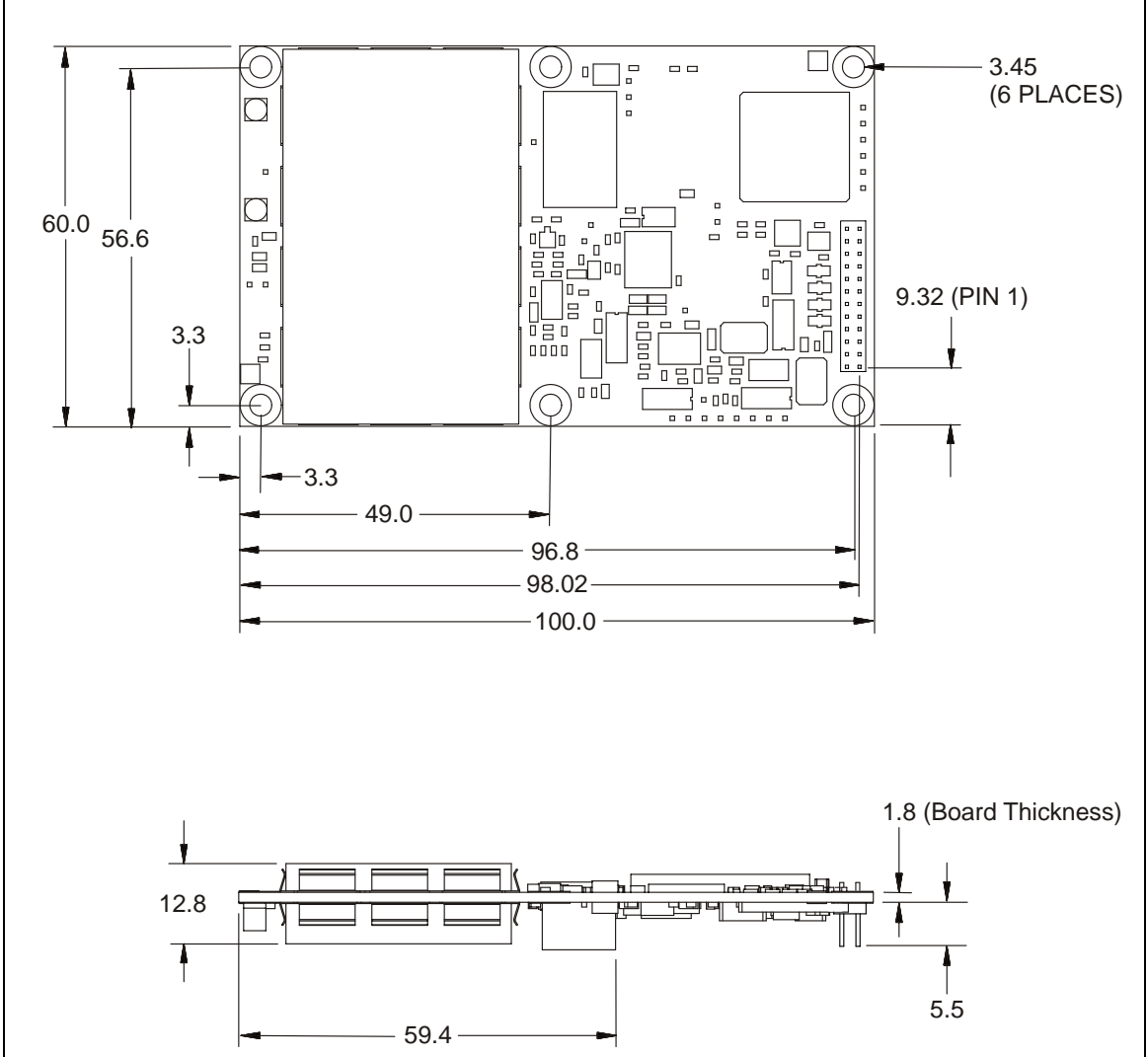

Figure 39: OEM4-G2L Board Dimensions

- a. All dimensions are in millimeters.
- b. The mounting holes on the OEM4-G2L GPSCard are designed for use with M3 screws.

ENVIRONMENTAL	
Operating Temperature	-40°C to +85°C
Storage Temperature	-45°C to +95°C
Humidity	Not to exceed 95% non-condensing
POWER REQUIREMENTS	
Voltage	+3.3 ± 0.15 VDC
Allowable Input Voltage Ripple	150 mV p-p (max.)
Power consumption	1.6 W (typical)
RF INPUT / LNA POWER OUTPUT	
Antenna Connector	MMCX female, 50 Ω nominal impedance, see <i>Figure 9 on Page 33</i>
RF Input Frequencies	1575.42 MHz (L1), 1227.60 MHz (L2)
LNA Power (output from card)	+4.75 to +5.10 VDC @ 0 - 100 mA
EXTERNAL OSCILLATOR INPUT	
Connector	MMCX female, see <i>Figure 9 on Page 33</i>
External Clock Input	Frequency: 5 MHz or 10 MHz Input Impedance: 50 Ω nominal Input VSWR: 2.0:1 Signal Level: 0 dBm minimum to +13.0 dBm maximum Frequency Stability: ± 0.5 ppm maximum Wave Shape: Sinusoidal
INPUT/OUTPUT DATA INTERFACE	
COM1	
Electrical format	RS232
Bit rates ^a	300, 1200, 4800, 9600 (default), 19200, 38400, 57600, 115200, 230400
Lead input	CTS
Lead output	RTS
Signals supported	TX, RX, RTS, CTS
COM2	
Electrical format	LVTTTL
Bit rates ^a	300, 1200, 4800, 9600 (default), 19200, 38400, 57600, 115200, 230400 bps
Lead input	CTS
Lead output	RTS
Signals supported	TX, RX, RTS, CTS
USB (Requires Firmware Version 2.100 or higher)	
Signals supported	USB D(+), USB D(-)

a. Baud rates higher than 115,200 bps are not supported by standard PC hardware. Special PC hardware is required for higher rates, including 230400 bps.

INPUT/OUTPUT STROBES	
Event1 (Mark 1 Input)	An input mark for which a pulse greater than 105 ns triggers certain logs to be generated. (Refer to the MARKPOS and MARKTIME logs and ONMARK trigger in <i>Volume 2</i> of this manual set). Polarity is configurable using the MARKCONTROL command discussed in <i>Volume 2</i> of this manual set. The mark inputs have 10K pull-up resistors to 3.3 V and are leading edge triggered.
Event2 (Mark 2 Input)	An input mark for which a pulse greater than 55 ns triggers certain logs to be generated. (Refer to the MARK2POS and MARK2TIME logs in <i>Volume 2</i> of this manual set). Polarity is configurable using the MARKCONTROL command discussed in <i>Volume 2</i> of this manual set. The mark inputs have 10K pull-up resistors to 3.3 V and are leading edge triggered.
PV (Position Valid)	Output that indicates whether a valid GPS position solution is available. A high level indicates a valid solution or that the FIX POSITION command has been set (refer to the FIX POSITION command in <i>Volume 2</i> of this manual set).
ERROR	Output for which a high level indicates an error.
PPS (Pulse Per Second)	A time synchronization output. This is a pulse (1 ms ± 50 ns) where the leading edge is synchronized to receiver calculated GPS time. The polarity and period of the pulse can be configured using the PPSCONTROL command described in <i>Volume 2</i> of this manual set.
VARF (Variable Frequency)	A programmable variable frequency output ranging from 0 -20 MHz (refer to the FREQUENCYOUT command in <i>Volume 2</i> of this manual set). This is a normally high, active low pulse.
RESETIN	Reset LVTTTL signal input (2.4 to 3.3 VDC maximum) from external system; active low, > 20 µs duration.
STROBE ELECTRICAL SPECIFICATIONS	
Outputs	Voltage: LVTTTL levels Low: minimum 0 VDC and maximum 0.4 VDC @ 5 mA High: minimum 2.4 VDC and maximum 3.3 VDC @ 5 mA
Event1 and Event2 Inputs	Voltage: LVTTTL levels Low: minimum 0 VDC and maximum 0.8 VDC High: minimum 2.0 VDC and maximum 5.5 VDC
RESETIN Input	Voltage: LVTTTL levels Low: minimum 0 VDC and maximum 0.8 VDC High: minimum 2.4 VDC and maximum 3.3 VDC

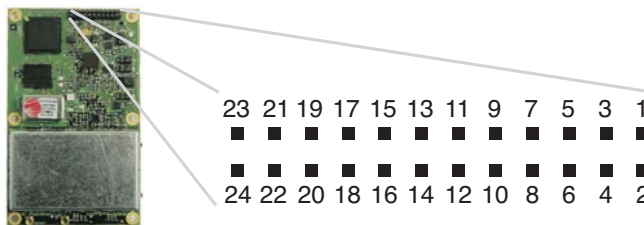

Figure 40: Top-view of 24-Pin Connector on the OEM4-G2L

Signal	Descriptions	Pin
GND	Digital Ground	1
GND	Digital Ground	2
VARF	Variable frequency out	3
PPS	Output pulse 1 ms wide for which the leading edge is used as the reference. Polarity and period can be configured using the PPSCONTROL command described in <i>Volume 2</i> of this manual set.	4
VCC	Voltage input, $+3.3 \pm 0.15$ VDC	5
VCC	Voltage input, $+3.3 \pm 0.15$ VDC	6
Event2	Mark 2 input, which requires a pulse longer than 55 ns. Polarity can be configured using MARKCONTROL detailed in <i>Volume 2</i> of this manual set.	7
Event1	Mark 1 input, which requires a pulse longer than 105 ns. Polarity can be configured using MARKCONTROL detailed in <i>Volume 2</i> of this manual set.	8
ERROR	Indicates fatal error when high	9
PV	Output indicates 'good solution' or valid GPS position when high.	10
CTS2	Clear to Send for COM 2 input	11
RESETIN	Reset LVTTTL signal input (2.4 to 3.3 VDC maximum) from external system; active low.	12
RTS2	Request to Send for COM 2 output	13
RXD2	Received Data for COM 2 input	14
CTS1	Clear to Send for COM 1 input	15
TXD2	Transmitted Data for COM 2 output	16
RTS1	Request to Send for COM 1 output	17
RXD1	Received Data for COM 1 input	18
GPIO_USER0	Reserved. 10 k Ω pull-up resistor internal to OEM4-G2L.	19
TXD1	Transmitted Data for COM 1 output	20
USB D-	USB interface data (-) (Requires firmware version 2.100 or higher)	21
USB D+	USB interface data (+) (Requires firmware version 2.100 or higher)	22
GND	Digital Ground	23
GND	Digital Ground	24

☒ To create a common ground, tie together all digital grounds (GND) with the ground of the power supply.

A.3 OEM4-G2 GPSCard

PHYSICAL

Size	85mm x 125mm x 12.8mm with connectors
Weight	85 grams

MECHANICAL DRAWINGS

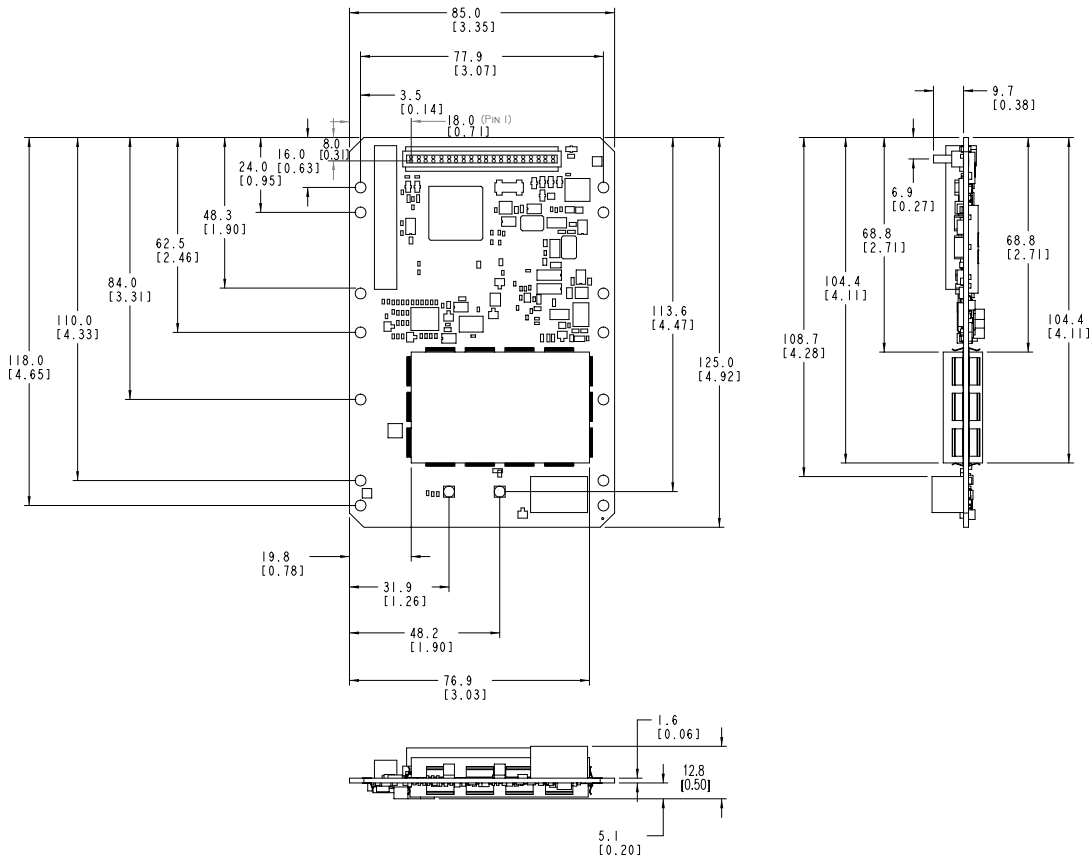

Figure 41: OEM4-G2 Board Dimensions

- a. All dimensions are in millimeters [inches]
- b. The mounting holes on the OEM4-G2 GPSCard are designed for use with M3 screws. The hole size is actually 3.45 mm (#29 drill, 0.136"), which is a British Standard "medium fit"

ENVIRONMENTAL

Operating Temperature	-40°C to +85°C
Storage Temperature	-45°C to +95°C
Humidity	Not to exceed 95% non-condensing

POWER REQUIREMENTS

Voltage	+4.5 to +18.0 VDC
Allowable Input Voltage Ripple	100 mV p-p (max.)
Power consumption	2.3 W (typical)

RF INPUT / LNA POWER OUTPUT

Antenna Connector (See <i>Figure 10 on Page 34</i>)	MMCX female, 50 Ω nominal impedance
RF Input Frequencies	1575.42 MHz (L1), 1227.60 MHz (L2)
LNA Power Internal (Output from card, default)	+4.75 to +5.10 VDC @ 0 - 100 mA
External (Optional Input)	+12 to +30 VDC, 100 mA max. (user-supplied)

EXTERNAL OSCILLATOR INPUT

Connector (See <i>Figure 10 on Page 34</i>)	MMCX female
External Clock Input	Frequency: 5 MHz or 10 MHz Input Impedance: 50 Ω nominal Input VSWR:2.0:1 Signal Level: 0 dBm minimum to +13.0 dBm maximum Frequency Stability: \pm 0.5 ppm maximum Wave Shape: Sinusoidal

INPUT/OUTPUT DATA INTERFACE	
COM1	
Electrical format	User-selectable. Defaults to RS232 but can be configured for RS422. See <i>Section 3.2.5.1 on Page 36</i> for more details. (Can also be factory configured for LVTTTL operation)
Bit rates ^a	300, 1200, 4800, 9600 (default), 19200, 38400, 57600, 115200, 230400, 460800, 921600 bps
Lead input	CTS for RS232
Lead output	RTS for RS232
Signals supported	TX, RX, RTS, CTS for RS232 / TXD(+), TXD(-), RXD(+), RXD(-) for RS422
COM2	
Electrical format	RS232 (Can be factory configured for LVTTTL operation)
Bit rates ^a	300, 1200, 4800, 9600 (default), 19200, 38400, 57600, 115200, 230400 bps
Lead input	CTS and DCD
Lead output	RTS and DTR
Signals supported	TX, RX, RTS, CTS, DTR, DCD
COM3	
Electrical format	LVTTTL
Bit rates ^a	300, 1200, 4800, 9600 (default), 19200, 38400, 57600, 115200, 230400 bps
Lead input	CTS
Lead output	RTS
Signals supported	TX, RX, RTS, CTS
USB	
(Requires Firmware Version 2.100 or higher)	
Signals supported	USB D(+), USB D(-)

a. Baud rates higher than 115,200 bps are not supported by standard PC hardware. Special PC hardware may be required for higher rates, including 230400 bps, 460800 bps, and 921600 bps.

INPUT/OUTPUT STROBES

MSR (Measure Output)	Normally high, active low where the pulse width is 1 ms. The leading edge is the receiver measurement strobe.
Event1 (Mark 1 Input)	An input mark for which a pulse greater than 65 ns triggers certain logs to be generated. (Refer to the MARKPOS and MARKTIME logs and ONMARK trigger in <i>Volume 2</i> of this manual set). Polarity is configurable using the MARKCONTROL command discussed in <i>Volume 2</i> . The mark inputs have 10K pull-up resistors to 3.3 V and are leading edge triggered.
Event2 (Mark 2 Input)	An input mark for which a pulse greater than 400 ns triggers certain logs to be generated. (Refer to the MARK2POS and MARK2TIME logs in <i>Volume 2</i> of this manual set). Polarity is configurable using the MARKCONTROL command discussed in <i>Volume 2</i> . The mark inputs have 10K pull-up resistors to 3.3 V and are leading edge triggered.
PV (Position Valid)	Indicates a valid GPS position solution is available. A high level indicates a valid solution or that the FIX POSITION command has been set (refer to the FIX POSITION command in <i>Volume 2</i> of this manual set).
ERROR	High level indicates an error.
STATUS_RED	Status output which is high or pulses to indicate that the OEM4-G2 card is not working properly.
STATUS_GREEN	Status output which pulses to indicate that the OEM4-G2 card is working properly.
PPS (Pulse Per Second)	A time synchronization output. This is a pulse (1 ms \pm 50 ns) where the leading edge is synchronized to receiver calculated GPS time. The polarity and period of the pulse can be configured using the PPSCONTROL command described in <i>Volume 2</i> of this manual set.
VARF (Variable Frequency)	A programmable variable frequency output ranging from 0 -20 MHz (refer to the FREQUENCYOUT command in <i>Volume 2</i> of this manual set). This is a normally high, active low pulse.
RESETOUT	Reset TTL signal output to external system; active low, 140 ms duration.
RESETIN	Reset LVTTTL signal input from external system; active low, > 20 μ s duration

STROBE ELECTRICAL SPECIFICATIONS

Output	Voltage:	LVTTTL levels
	Low:	minimum 0 VDC and maximum 0.55 VDC @ 24 mA
	High:	minimum 2.4 VDC and maximum 3.6 VDC @ 8 mA
Input	Voltage:	LVTTTL levels
	Low:	minimum 0 VDC and maximum 0.8 VDC
	High:	minimum 2.0 VDC and maximum 5.5 VDC
RESETIN Input	Voltage:	LVTTTL levels
	Low:	minimum 0 VDC and maximum 0.8 VDC
	High:	minimum 2.4 VDC and maximum 3.3 VDC

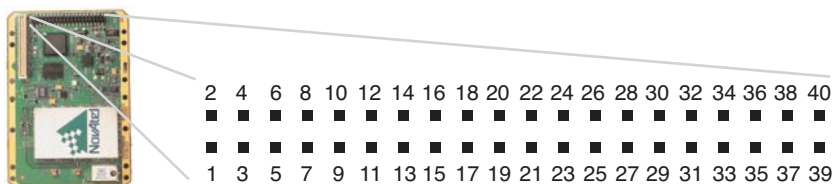

Figure 42: Top-view of 40-Pin Connector on the OEM4-G2

Signal	Descriptions	Pin
V _{IN}	Voltage In, +4.5 to +18 VDC	1
PV	Output indicates 'good solution' or valid GPS position when high.	2
USB D+	USB interface data (+) (Requires firmware version 2.100 or higher)	3
GND	Digital Ground	4
USB D-	USB interface data (-) (Requires firmware version 2.100 or higher)	5
GND	Digital Ground	6
PPS	Output pulse 1 ms wide for which the leading edge acts as the reference. Polarity and period can be configured using the PPSCONTROL command described in <i>Volume 2</i> of this manual set.	7
GND	Digital Ground	8
VARF	Variable frequency out	9
GND	Digital Ground	10
Event1	Mark 1 input, which requires a pulse longer than 65 ns. Polarity can be configured using the MARKCONTROL command detailed in <i>Volume 2</i> of this manual set. The mark inputs have 10K pull-up resistors to 3.3 V and are leading edge triggered.	11
GND	Digital Ground	12
STATUS_RED	Indicates the OEM4-G2 card is not working properly when high or pulsing.	13
CTS1/RXD1(-)	COM1 input Clear to Send for RS-232 / Received Data (-) for RS-422	14
TXD1/TXD1(+)	COM1 output Transmitted Data for RS-232 / Transmitted Data (+) for RS-422	15
RTS1/TXD1(-)	COM1 output Request to Send for RS-232 / Transmitted Data (-) for RS-422	16
RXD1/RXD1(+)	COM1 input Received Data for RS-232 / Received Data (+) for RS-422	17
CTS3	Clear to Send for COM 3 input	18
TXD3	Transmitted Data for COM 3 output	19
DCD2	Data Carrier Detected for COM 2 input	20
RXD3	Received Data for COM 3 input	21
RTS3	Request to Send for COM 3 output	22
DTR2	Data Terminal Ready for COM 2 output	23
CTS2	Clear to Send for COM 2 input	24
TXD2	Transmitted Data for COM 2 output	25
RTS2	Request to Send for COM 2 output	26

Continued on Page 126

RXD2	Received Data for COM 2 input	27
STATUS_GREEN	Indicates the OEM4-G2 card is working properly when pulsing at 1 Hz.	28
GPIO_USER0	Reserved. 10 k Ω pull-down resistor internal to OEM4-G2.	29
USERIO1	COM1 port configuration selector. 10 k Ω pull-down resistor internal to OEM4-G2. (At startup, tie high to set COM1 to RS-422 or leave open for RS-232. See <i>Section 3.2.5.1 on Page 36</i> for more details.)	30
Event2 / GPIO_USER2	Mark 2 input, which requires a pulse longer than 400 ns. Polarity can be configured or processing can be disabled using MARKCONTROL detailed in <i>Volume 2</i> of this manual set. The mark inputs have 10K pull-up resistors to 3.3 V and are leading edge triggered.	31
MSR	Normally high, active low pulse is 1 ms \pm 50 ns wide. leading edge is used as the reference.	32
RESETIN	Reset LVTTTL signal input (2.4 to 3.3 VDC maximum) from external system; active low.	33
GPAI	General purpose analog input (refer to the RXHWLEVELS log in <i>Volume 2</i> of this manual set). The voltage range is 0.0 (min.) to 2.75 (max) VDC.	34
RESETOUT	Reset TTL signal output to external system; active low.	35
GND	Digital Ground	36
GPIO_FR	Reserved. 10 k Ω pull-up resistor internal to OEM4-G2.	37
ERROR	Indicates fatal error when high	38
*	Reserved.	39
LNA_PWR	Optional external power to antenna other than a standard NovAtel GPSAntenna (refer to the ANTENNAPOWER command in <i>Volume 2</i> of this manual set)	40

☒ To create a common ground, tie together all digital grounds (GND) with the ground of the power supply.

A.4 FlexPak

INPUT/OUTPUT CONNECTORS	
ANT	Waterproof TNC female jack, 50 Ω nominal impedance +4.75 to +5.10 VDC, 100 mA max (output from FlexPak to antenna/ LNA)
PWR	3-pin waterproof Deutsch connector +6 to +18 VDC (Deutsch PN 59065-09-98PN)
COM1	13-pin waterproof Deutsch connector (Deutsch P/N 59065-11-35PF)
COM2	13-pin waterproof Deutsch connector ^a (Deutsch P/N 59065-11-35PF)
PHYSICAL	
Size	45 x 147 x 123 mm
Weight	350 g maximum
Mounting System	Integral flange with two 7 mm (9/32 inch) diameter mounting holes 133 mm (5.25 inches) apart
ENVIRONMENTAL	
Operating Temperature	-40°C to +75°C
Storage Temperature	-40°C to +85°C
Humidity	Not to exceed 95% non-condensing
Waterproof	To IEC 60529 IP X7

- a. Normally RS-232 but can be dynamically changed to RS-422 by grounding Pin# 1 on the COM2 Deutsch connector. You can switch between RS-232 and RS-422 by changing the state of this pin. You do not have to cycle power on the FlexPak for this change to take effect.

Pin# 1 is a No Connect (N/C) at the DB9F end of the FlexPak communication cable, see *Page 133*. There are not enough pins on the DB9F connector to accommodate this extra pin. However, if you cut the COM cable you can access wires for all the pins on the Deutsch side of the cable, including the Deutsch Pin# 1.

DIMENSIONS

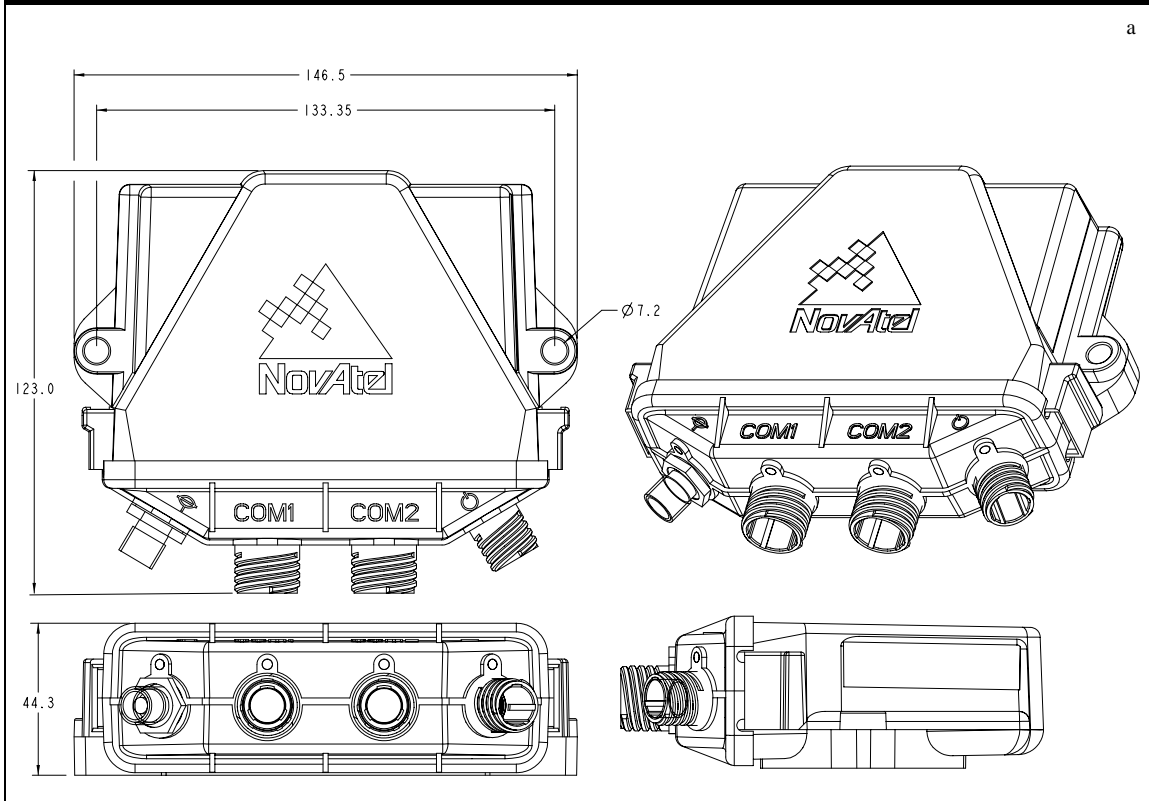

- a. All dimension are in millimeters, please use the *Unit Conversion* section of the *GPS+ Reference Manual* for conversion to imperial measurements.

A.4.1 Port Pin-Outs

The pin numbering for each of the ports, is described in the tables that follow.

Table 22: FlexPak COM1 Port Pin-Out Descriptions

Deutsch RS-232 Only	
Connector Pin No.	Signal Name
1	GPIO
2	RXD1
3	CTS1
4	EVENT1
5	GND
6	EVENT2
7	RTS1
8	TXD1
9	POUT
10	PPS
11	USB D+
12	USB D-
13	ERROR

☒ For strobe signal descriptions, please see *Section 3.3.1, Strokes on Page 36*.

Table 23: FlexPak COM2 Port Pin-Out Descriptions

Deutsch RS-232		Deutsch RS-422	
Pin	Function	Pin	Function
1	Select 232/422 Mode	1	Select 232/422 Mode
2	RXD2	2	RXD2(+)
3	CTS	3	RXD2(-)
4	Event 1	4	Event 1
5	GND	5	GND
6	Event 2	6	Event 2
7	RTS2	7	TXD2(-)
8	TXD2	8	TXD2(+)
9	POUT	9	POUT
10	PPS	10	PPS
11	USB D+	11	USB D+
12	USB D-	12	USB D-
13	ERROR	13	ERROR

☒ The cable supplied needs to be modified to work in RS-422 mode, see *Section A.4.2.3, 13-Pin Deutsch to DB9 Straight Cable (NovAtel part number 01017518) on Page 133.*

A.4.2 Cables

☒ Deutsch cable connector pin numbers are labelled on the connectors.

A.4.2.1 12V Power Adapter Cable (NovAtel part number 01017374)

The power adapter cable supplied with the FlexPak provides a convenient means for supplying +12 VDC while operating from a 12V source (the actual voltage range for the receiver is +6 to +18 VDC). The figure below shows the cable and a wiring diagram of the 12V adapter.

The output of the power adapter uses a 3-pin Deutsch socket (Deutsch part number: 59064-09-98SN). This cable plugs directly into the PWR port on the front of the FlexPak.

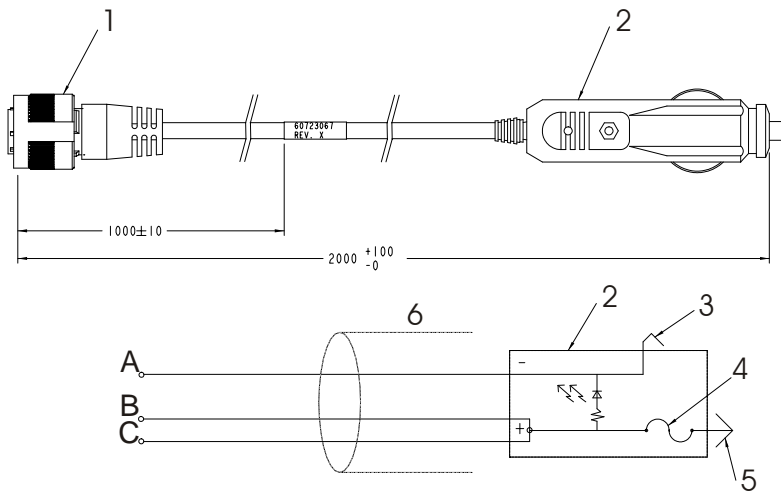

Reference	Description	Reference	Description
1	3-pin Deutsch connector	A	Black
2	12V adapter	B	Red
3	Outer contact	C	White/Natural
4	3 amp slow-blow fuse		
5	Center contact		
6	Foil shield		



Figure 43: FlexPak Power Cable

A.4.2.2 13-Pin Deutsch to DB9 Null Modem Cable (NovAtel part number 01017375)

The null modem serial cable shown below provides a means of interfacing between the COM1 or COM2 port on the FlexPak and another serial communications device, such as a PC. At the FlexPak end, the cable is equipped with a 13-pin Deutsch connector (Deutsch part number: 59064-11-35SF), which plugs directly into a COM port. At the other end, a RS-232 DB9S connector is provided. To use this cable in RS-422 mode, you must cut the DB-9 connector off and make a cable to match the COM2 port for RS-422, see *Section 23, FlexPak COM2 Port Pin-Out Descriptions on Page 130*. This cable looks identical to the straight through serial cable, see *Page 133*, but its use and part number differs. It is 2 meters in length.

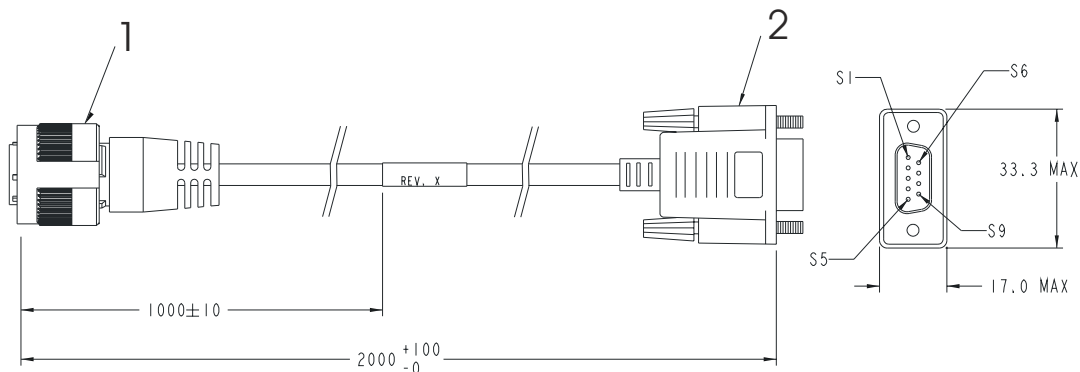

TO RECEIVER	COLOR	SIGNAL	DB-9 FEMALE TO PC
S1	BLUE/WHITE	GP10	N/C
S2	BROWN	RXD1	S3
S3	BROWN/WHITE	CTS1	S7
S4	GREEN	EVENT1	N/C
S5	BLUE	GND	S5
S6	GREEN/BLACK	EVENT2	N/C
S7	RED	RTS1	S8
S8	RED/BLACK	TXD1	S2
S9	YELLOW/BLACK	POUT	S1, S6
S10	ORANGE	PPS	N/C
S11	WHITE	USB D+	N/C
S12	WHITE/BLACK	USB D-	N/C
S13	ORANGE/BLACK	ERROR	N/C

Reference	Description
1	13-pin Deutsch connector
2	DB9S connector



Figure 44: FlexPak 13-Pin Serial Cable

A.4.2.3 13-Pin Deutsch to DB9 Straight Cable (NovAtel part number 01017518)

The straight through serial cable shown below is used to connect the FlexPak to a modem or radio transmitter to propagate differential corrections. At the FlexPak end, the cable is equipped with a 13-pin Deutsch connector (Deutsch part number: 59064-11-35SF), which plugs directly into a COM port. The male DB9 connector at the other end is provided to plug into your user-supplied equipment (please refer to your modem or radio transmitter user guide for more information on its connectors). This cable looks identical to the null modem serial cable, see *Page 132*, but its use and part number differs. It is 2 meters in length.

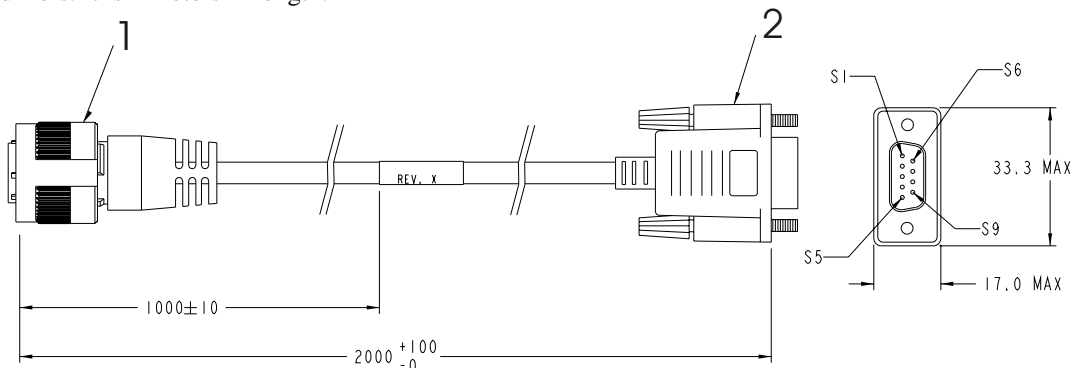

PINOUT ON RECEIVER END CONNECTOR		SIGNAL	DB-9 FEMALE
S1		GPIO	N/C
S2	PAIRED	RXD1	S2
S3		CTS1	S8
S4		EVENT1	N/C
S5		GND	S5
S6		EVENT2	N/C
S7	PAIRED	RTS1	S7
S8		TXD1	S3
S9	2 WIRES	POUT	S1
S9			S6
S10		PPS	N/C
S11	PAIRED	USB D+	N/C
S12		USB D-	N/C
S13		ERROR	N/C

Reference	Description
1	13-pin Deutsch connector
2	DB9S connector



Figure 45: FlexPak 13-Pin Serial Cable

A.4.2.4 USB Serial Cable (NovAtel part number 01017359)

The USB cable shown below provides a means of interfacing between the COM1 or COM2 port on the FlexPak and another serial communications device, such as a PC. At the FlexPak end, the cable is equipped with a 13-pin Deutsch connector (Deutsch part number: 59064-11-35SF), which plugs directly into the COM2 port. See also *Section A.4.2.3, 13-Pin Deutsch to DB9 Straight Cable (NovAtel part number 01017518) on Page 133*. At the other end, a USB connector is provided.

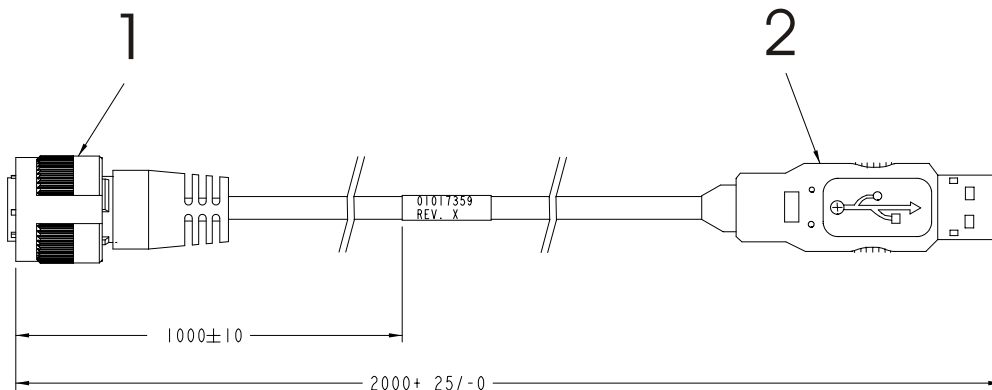

WIRING			
DEUTSCH CONN. ON RECEIVER	SIGNAL	SERIES "A" USB PLUG	WIRE COLOR
PIN 5	GND	PIN 4	BLACK
PIN 11	USB D+	PIN 3	GREEN
PIN 12	USB D-	PIN 2	WHITE
INSULATE TO PREVENT SHORT			RED

Reference	Description
1	Deutsch connector
2	USB connector

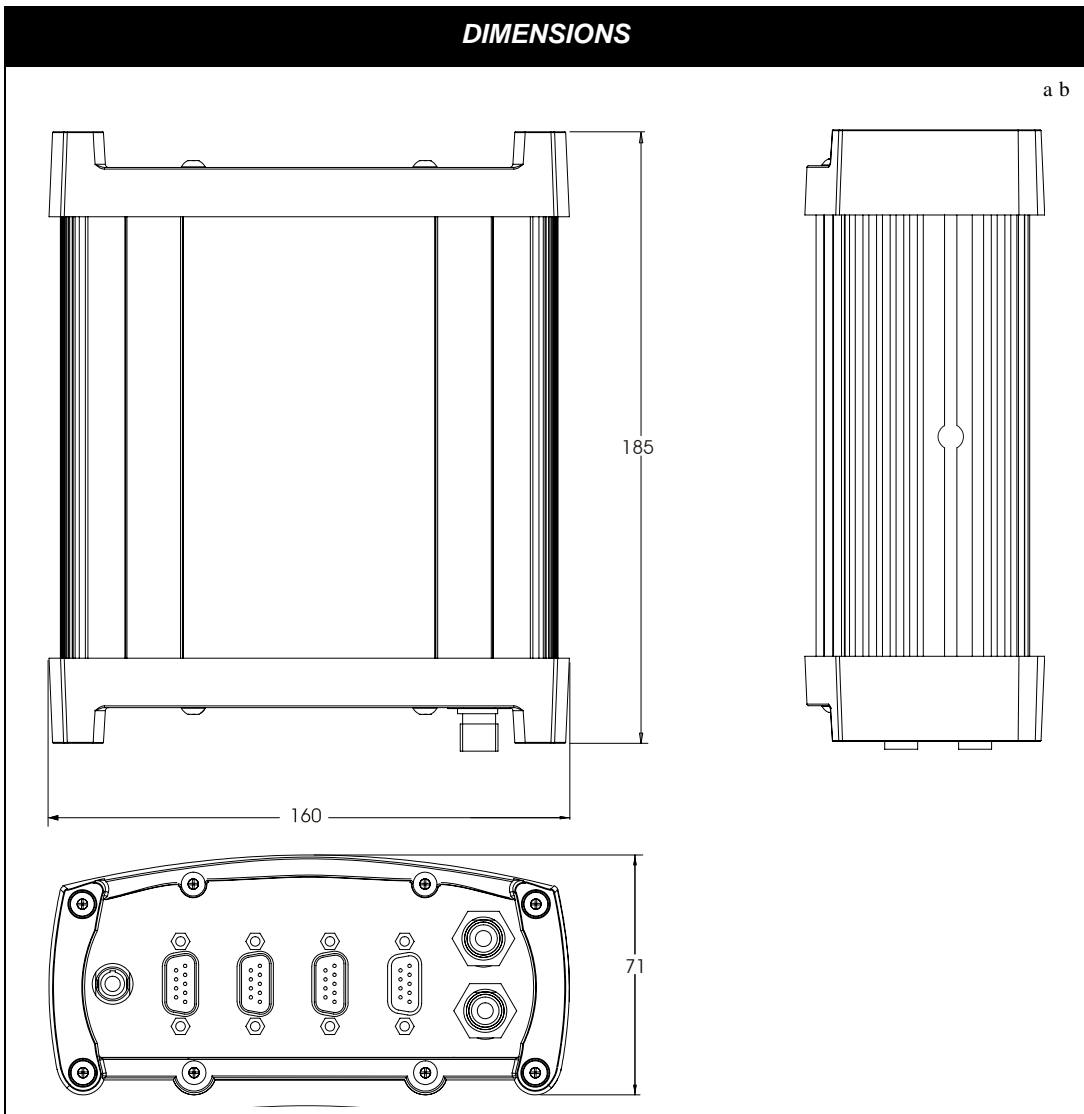

Figure 46: FlexPak USB Cable

A.5 ProPak-G2plus

INPUT/OUTPUT CONNECTORS	
Antenna Input	TNC female jack, 50 Ω nominal impedance +4.75 to +5.10 VDC, 100 mA max (output from ProPak-G2plus to antenna/LNA)
PWR	4-pin LEMO connector +7 to +18 VDC at 2.8 W (typical)
COM1 COM2 AUX I/O OSC	DB9P connector DB9P connector DB9P connector ^a DB9S connector BNC connector (external oscillator)
PHYSICAL	
Size	185 x 154 x 71 mm
Weight	1.0 kg maximum (including OEM4-G2 GPSCard)
ENVIRONMENTAL	
Operating Temperature	-40°C to +75°C
Storage Temperature	-45°C to +95°C
Humidity	Not to exceed 95% non-condensing

- a. The AUX port on the ProPak-G2plus supports input from an IMU. If applicable, refer also to your *SPAN User Manual*.



- a. All dimension are in millimeters, please use the *Unit Conversion* section of the *GPS+ Reference Manual* for conversion to imperial measurements.
- b. *Page 144* provides the dimension information for the mounting bracket.

A.5.1 Port Pin-Outs

Table 24: ProPak-G2plus Serial Port Pin-Out Descriptions

Connector Pin No.	COM1		COM2	AUX	
	RS232	RS422	RS232 Only	RS232	RS422
1	N/C	N/C	N/C	GND	GND
2	RXD1	RXD1+	RXD2	RXD3	RXD3+
3	TXD1	TXD1+	TXD2	TXD3	TXD3+
4	N/C	N/C	POUT	POUT	AUX
5	GND	GND	GND	GND	GND
6	D+	D+	N/C	N/C	N/C
7	RTS1	TXD1-	RTS2	RTS3	TXD3-
8	CTS1	RXD1-	CTS2	CTS3	RXD3-
9	D-	D-	N/C	N/C	N/C

Table 25: ProPak-G2plus I/O Port Pin-Out Descriptions

Connector Pin No.	Signal Name	Signal Descriptions
1	VARF	Variable frequency out
2	PPS	Pulse per second
3	MSR	Mark 1 output
4	EVENT1	Mark 1 input
5	PV	Valid position available
6	EVENT2	Mark 2 input, which requires a pulse longer than 400 ns. 10K ohm pull down resistor internal to the ProPak-G2plus. Refer also to the MARKCONTROL command in <i>Volume 2</i> of this manual set.
7	_RESETOUT	Reset TTL signal output to an external system. Active low.
8	ERROR	Indicates a fatal error when high.
9	GND	Digital ground

☒ For strobe signal descriptions, please see *Section 3.3.1, Strokes on Page 36*.

A.5.2 Cables

A.5.2.1 12V Power Adapter Cable (NovAtel part number 01017023)

The power adapter cable supplied with the ProPak-G2*plus*, see *Figure 47*, provides a convenient means for supplying +12 VDC while operating in the field.

Input is provided through the standard 12V power outlet. The output from the power adapter utilizes a 4-pin LEMO connector (LEMO part number FGG.0B.304.CLAD52Z) and plugs directly into the *PWR* input located on the back panel of the ProPak-G2*plus*.

For alternate power sources please see *Section 3.1.3 on Page 29*.

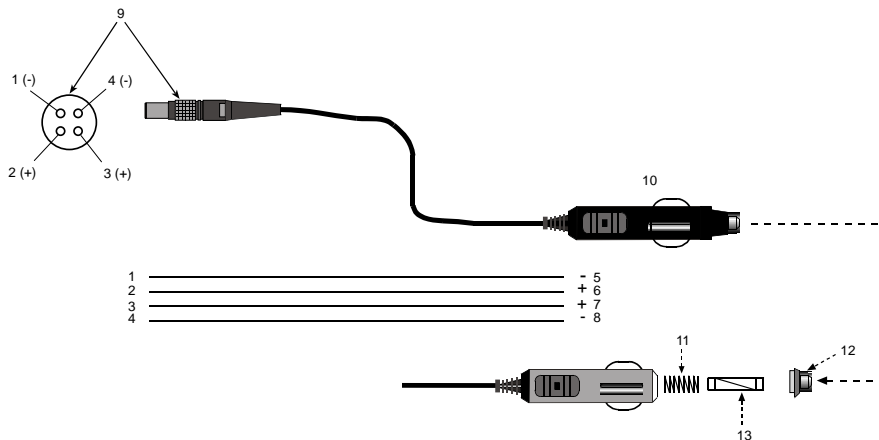

Reference	Description	Reference	Description
1	Black	5	Ground
2	Red	6	+7 to +18 VDC
3	Orange	7	+7 to +18 VDC
4	Brown	8	Ground
9	Connector key marking	12	Universal tip
10	12V adapter	13	6 Amp slow-blow fuse
11	Spring		



Figure 47: ProPak-G2*plus* Power Cable

A.5.2.2 Null Modem Cable (NovAtel part number 60323062)

This cable supplied with the ProPak-G2plus, see *Figure 48*, provides an easy means of communications with a PC. The cable is equipped with a 9-pin connector at the receiver end which can be plugged into the *COM1*, *COM2*, or *AUX* port. At the PC end, a 9-pin connector is provided to accommodate a PC serial (RS232) communication port.

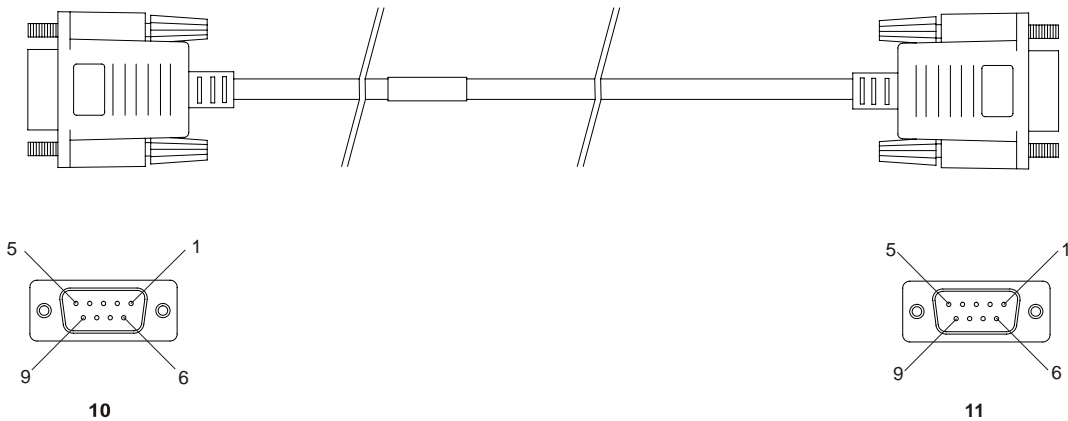

Wiring Table:

Connector	Pin Number						
To DB9S (10)	2	3	8	7	4	5	1 & 6
To DB9S (11)	3	2	7	8	1 & 6	5	4

Reference	Description
10	DB9S (Female)
11	DB9S (Female)



Figure 48: ProPak-G2plus Null Modem Cable

A.5.2.3 Straight Through Serial Cable (NovAtel part number 60723066)

This cable can be used to connect the ProPak-G2*plus* to a modem or radio transmitter to propagate differential corrections. The cable is equipped with a female DB9 connector at the receiver end. The male DB9 connector at the other end is provided to plug into your user-supplied equipment (please refer to your modem or radio transmitter user guide for more information on its connectors). The cable is approximately 2 m in length. See *Figure 49*.

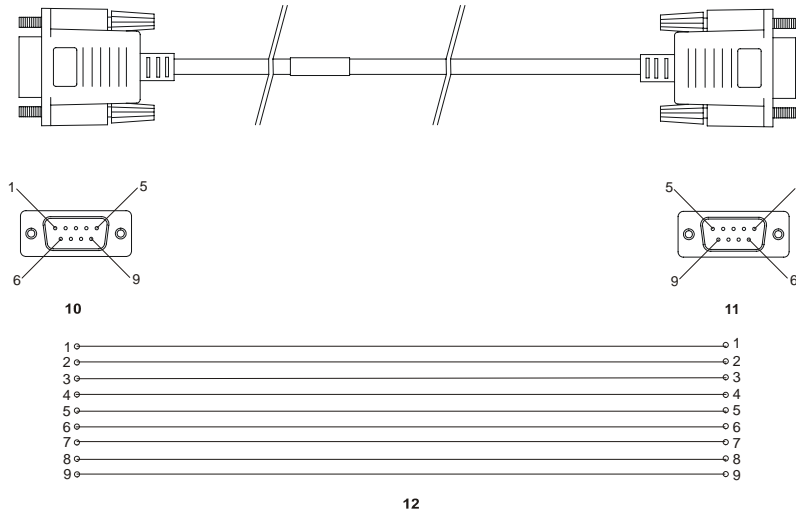

Reference	Description	Reference	Description
10	DB9P (male) connector	12	9-conductor cable
11	DB9S (female) connector		



Figure 49: ProPak-G2*plus* Straight Through Serial Cable

A.5.2.4 I/O Strobe Port Cable (NovAtel part number 60723065)

The strobe lines on the ProPak-G2plus can be accessed by inserting the male DB9 connector of the I/O strobe port cable into the I/O port. The other end of this cable is provided without a connector to provide flexibility. The jacket insulation is cut away slightly from the end but the insulation on each wire is intact. The cable is approximately 2 m in length. See Figure 50.

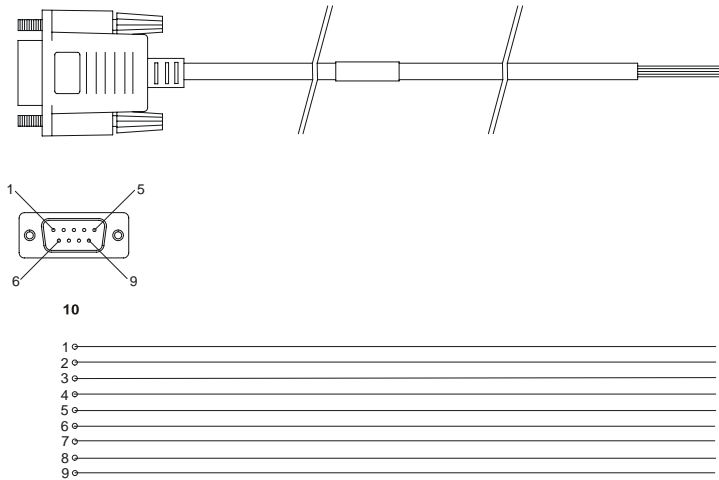

11

Wiring Table:

I/O Port Pin	I/O Port Signal	I/O Port Cable Wire Color	I/O Port Pin	I/O Port Signal	I/O Port Cable Wire Color
1	VARF	Black	6	Reserved	Green
2	PPS	Brown	7	Reserved	Blue
3	Reserved	Red	8	GND	Violet
4	Event1	Orange	9	GND	White/Grey
5	PV	Yellow			

Reference	Description	Reference	Description
10	DB9P (male) connector	11	9-conductor cable



Figure 50: ProPak-G2plus I/O Strobe Port Cable

A.5.2.5 USB Serial Cable (NovAtel part number 01017408)

The USB cable shown below provides a means of interfacing between the COM1 port on the ProPak-G2*plus* and another serial communications device, such as a PC. At the ProPak-G2*plus* end, the cable is equipped with a DB9 connector, which plugs directly into a COM port. At the other end, a USB connector is provided.

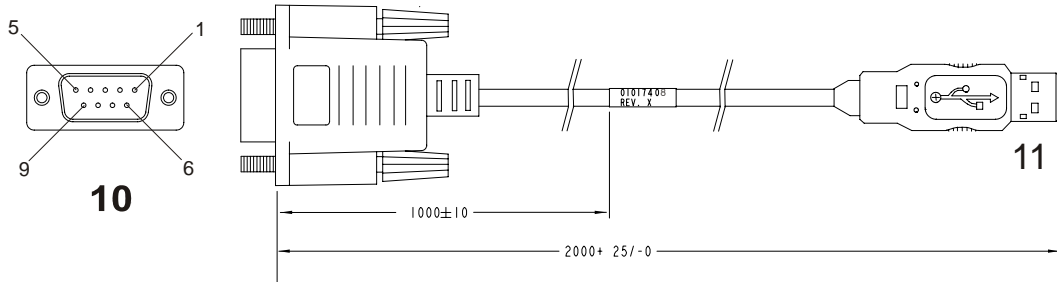





WIRING			
DB9 CONNECTION ON RECEIVER	SIGNAL	SERIES "A" USB PLUG	WIRE COLOR
PIN 5	GND	PIN 4	BLACK
PIN 6	USB D+	PIN 3	GREEN
PIN 9	USB D-	PIN 2	WHITE
INSULATE TO PREVENT SHORT			RED

Reference	Description
10	Female DB9 connector
11	USB connector

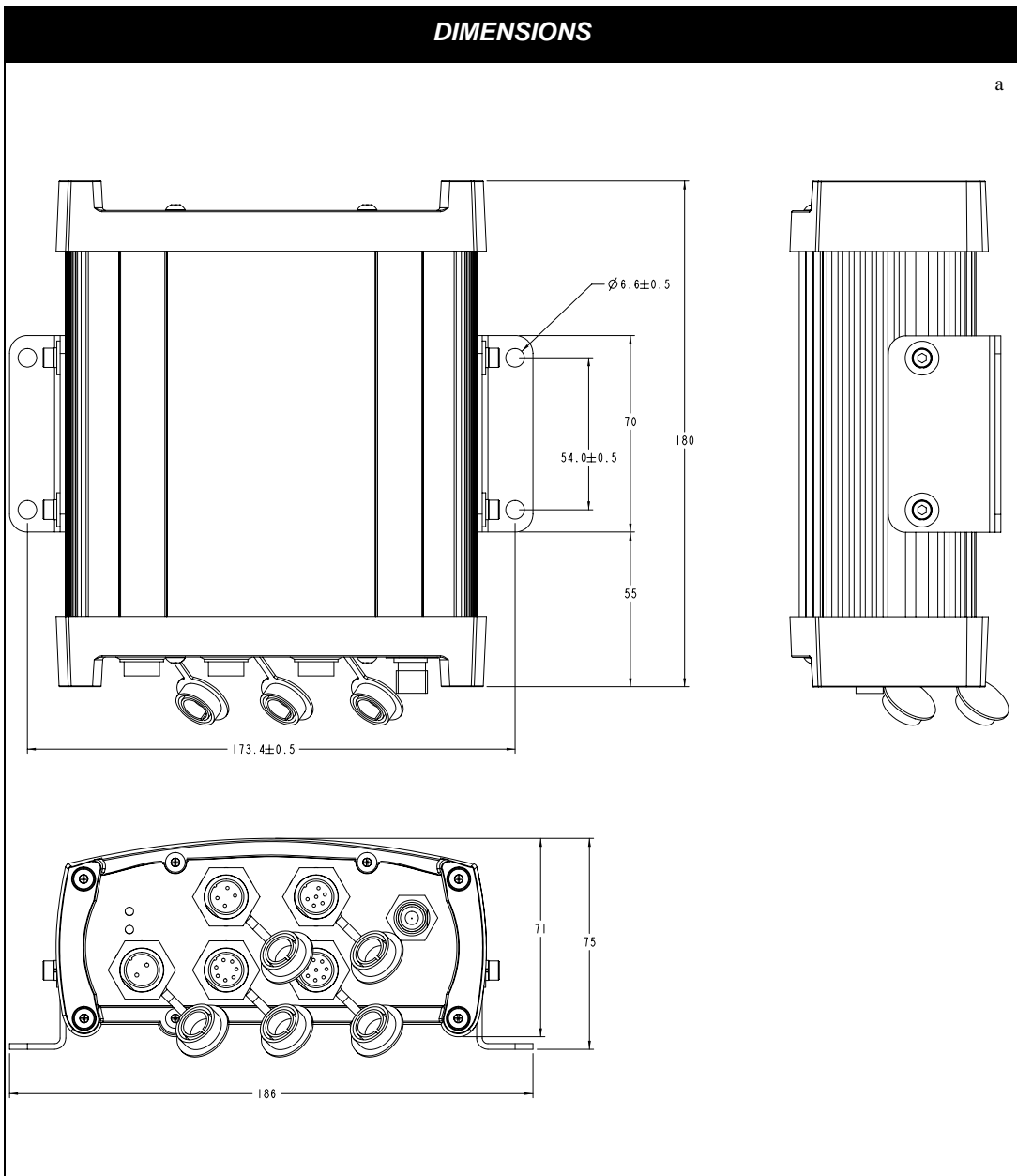

Figure 51: USB Serial Cable

A.6 ProPak-LBplus

INPUT/OUTPUT CONNECTORS		
Antenna		TNC female jack, 50 Ω nominal impedance +4.75 to +5.10 VDC, 100 mA max (output from ProPak-LBplus to antenna/LNA)
Power		2-pin Switchcraft EN3 connector +7 to +15 VDC at 3.7 W typical (operating range) ^a
COM1		6-pin Switchcraft EN3 connector
COM2		7-pin Switchcraft EN3 connector
COM3		8-pin Switchcraft EN3 connector ^b
PHYSICAL		
Size		185 x 154 x 71 mm (not including mounting bracket) 180 x 186 x 75 mm (including mounting bracket)
Weight		1.1 kg maximum
ENVIRONMENTAL		
Operating Temperature		-40°C to +75°C
Storage Temperature		-40°C to +90°C
Humidity		Not to exceed 95% non-condensing

- a. The receiver will turn off and be undamaged at voltages between 15 and 30 VDC. Protection is included for brief transients above 30 VDC.
- b. The RS232 driver used to monitor the port, shuts down if there is no cable connected in order to conserve power. This AUTO ON-LINER feature allows the device to automatically "wake-up" during a shut down state when an RS232 cable is connected and a connected peripheral is turned on. Otherwise, the device automatically shuts itself down drawing less than 1A.



a. All dimension are in millimeters, please use the *Unit Conversion* section of the *GPS+ Reference Manual* for conversions.

A.6.1 Port Pin-Outs

Figure 52 is included to provide the pin numbering for each of the ports, which are described in the tables that follow.

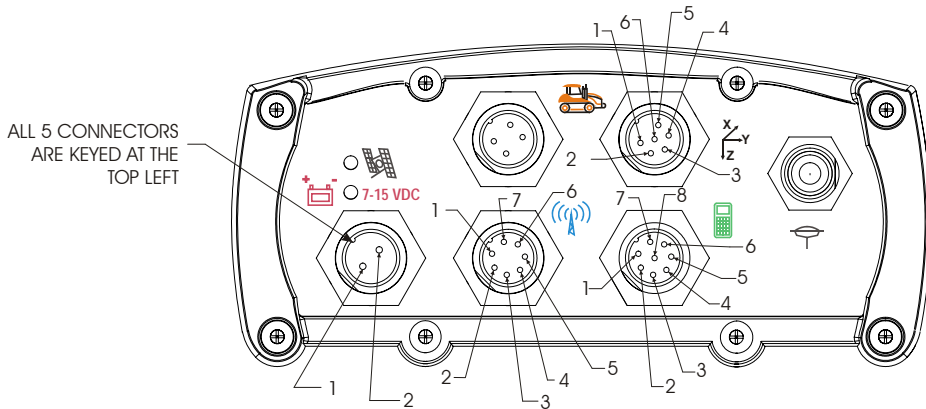

Figure 52: ProPak-LBplus Port Pin-Outs

Table 26: ProPak-LBplus Power Port Pin-Out Descriptions



Connector Pin No.	Signal Name	Signal Description
1	VIN+	Positive power terminal
2	VIN-	Negative power terminal

Table 27: ProPak-LBplus COM1 Port Pin-Out Descriptions



Connector Pin No.	Signal Name	Signal Description
1	PPS	Pulse per second output
2	Event1	Mark 1 input
3	POUT	Power output ^a
4	RXD1	RS232 receive to COM1 on the receiver
5	TXD1	RS232 transmit from COM1 on the receiver
6	GND	Signal/power ground

a. Both COM1 and COM2 have power output pins that can be used to pass power to peripherals. The voltage on each will be approximately 1 V lower than VIN. The maximum continuous current is 500 mA.

☒ For strobe signal descriptions, please see *Section 3.3.1, Strokes on Page 36*.

Table 28: ProPak-LBplus COM2 Port Pin-Out Descriptions



Connector Pin No.	Signal Name	Signal Description
1	SGND	Signal ground
2	RTS2	RS232 ready to send from COM2 on the receiver
3	CTS2	RS232 clear to send to COM2 on the receiver
4	POUT	Power output ^a
5	RXD2	RS232 receive to COM2 on the receiver
6	TXD2	RS232 transmit from COM2 on the receiver
7	PGND	Power ground ^a

- a. Both COM1 and COM2 have power output pins that can be used to pass power to peripherals. The voltage on each will be approximately 1 V lower than VIN. The maximum continuous current is 500 mA.

Table 29: ProPak-LBplus COM3 Port Pin-Out Descriptions



Connector Pin No.	Signal Name	Signal Description
1	Reserved	Reserved
2	GPIO_SR	Reserved
3	RXD3	RS232 receive to COM3 on the receiver
4	TXD3	RS232 transmit from COM3 on the receiver
5	AIN	General purpose analog input (refer to the <i>RXHWLEVELS</i> log in <i>Volume 2</i> of this manual set)
6	GPIO_SL	Reserved
7	GND	Digital ground
8	GPIO_GPI	Reserved

A.6.2 Cables

A.6.2.1 12V Power Adapter Cable (NovAtel part number 60723064)

The power adapter cable supplied with the ProPak-LBplus provides a convenient means for supplying +12 VDC while operating in the field.

The output of the power adapter uses a 2-pin Switchcraft socket (Switchcraft part number: EN3C2F). This cable plugs directly into the power port on the rear end cap of the ProPak-LBplus.

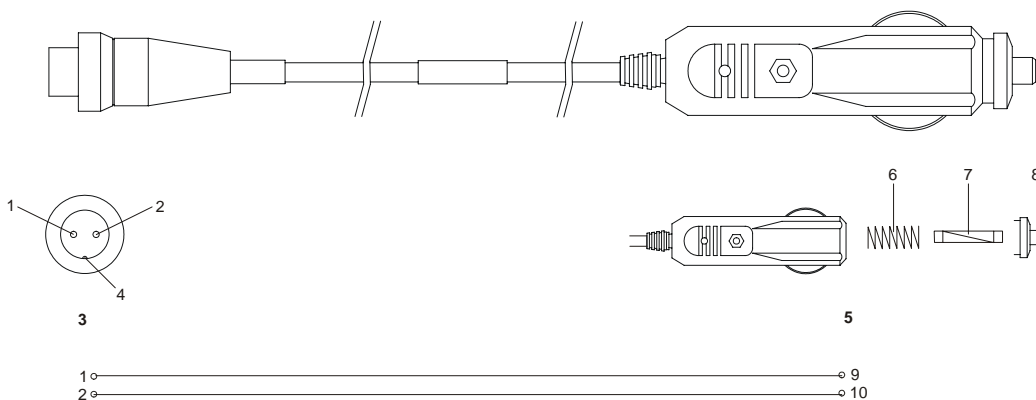

Reference	Description
3	2-pin Switchcraft EN3C2F connector
4	Connector key
5	12V power outlet plug
6	Spring
7	3A slow blow fuse
8	Universal tip
9	Red/Orange (+ve)
10	Black/Brown (-ve)



Figure 53: ProPak-LBplus Power Cable

A.6.2.2 6-Pin Switchcraft to DB9 Serial Cable (NovAtel part number 60723061)

The serial cable shown below provides a means of interfacing between the COM1 port on the ProPak-LB*plus* and another serial communications device, such as a PC. At the ProPak-LB*plus* end, the cable is equipped with a 6-pin Switchcraft connector (Switchcraft part number: EN3C6F), which plugs directly into the COM1 port. At the other end, a DB9S connector is provided. The cable is 2 m in length.

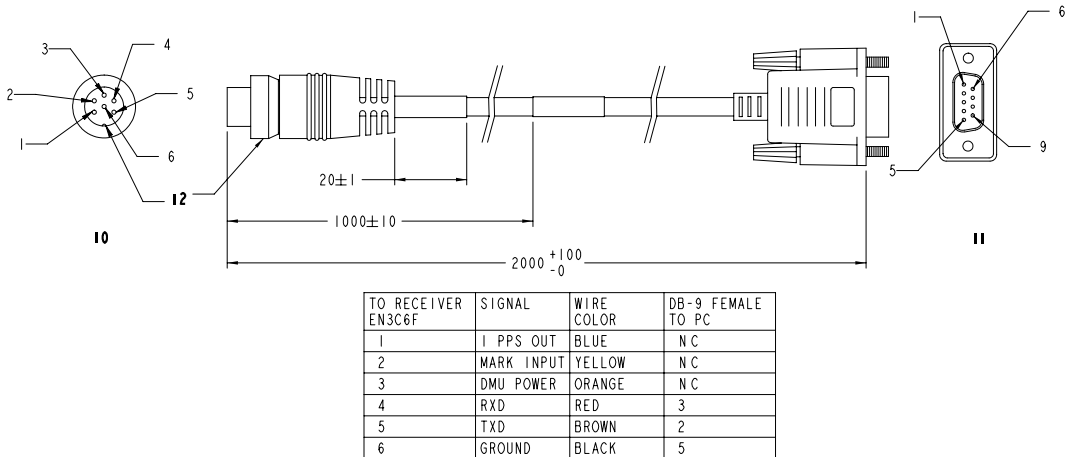

Reference	Description
10	6-pin Switchcraft EN3C6F connector
11	DB9S connector
12	Connector key



Figure 54: ProPak-LB*plus* 6-Pin Serial Cable

A.6.2.3 7-Pin Switchcraft to DB9 Serial Cable (NovAtel part number 60723062)

The serial cable shown below provides a means of interfacing between the COM2 port on the ProPak-LBplus and another serial communications device, such as a PC. At the ProPak-LBplus end, the cable is equipped with a 7-pin Switchcraft connector (Switchcraft part number: EN3C7F), which plugs directly into the COM2 port. At the other end, a DB9S connector is provided.

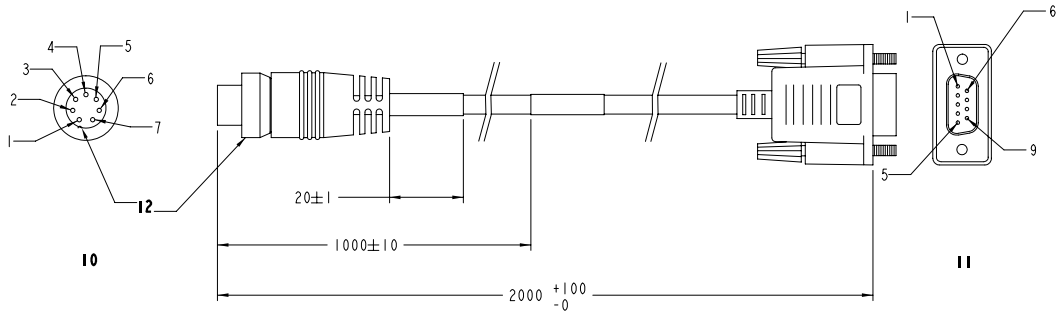

TO RECEIVER EN3C7F	SIGNAL	WIRE COLOR	TO PC DB-9 SOCKET
1	SGND	GREEN	NC
2	RTS2	ORANGE	8
3	CTS2	BLUE	7
4	RADPWR	YELLOW	NC
5	RXD2	RED	3
6	TXD2	BROWN	2
7	GROUND	BLACK	5

Reference	Description
10	7-pin Switchcraft EN3C7F connector
11	DB9S connector
12	Connector key



Figure 55: ProPak-LBplus 7-Pin Serial Cable

A.6.2.4 8-Pin Switchcraft to DB9 Serial Cable (NovAtel part number 60723063)

The serial cable shown below provides a means of interfacing between the COM3 port on the ProPak-LB*plus* and another serial communications device, such as a PC. At the ProPak-LB*plus* end, the cable is equipped with a 8-pin Switchcraft connector (Switchcraft part number: EN3C8F), which plugs directly into the COM3 port. At the other end, a DB9S connector is provided.

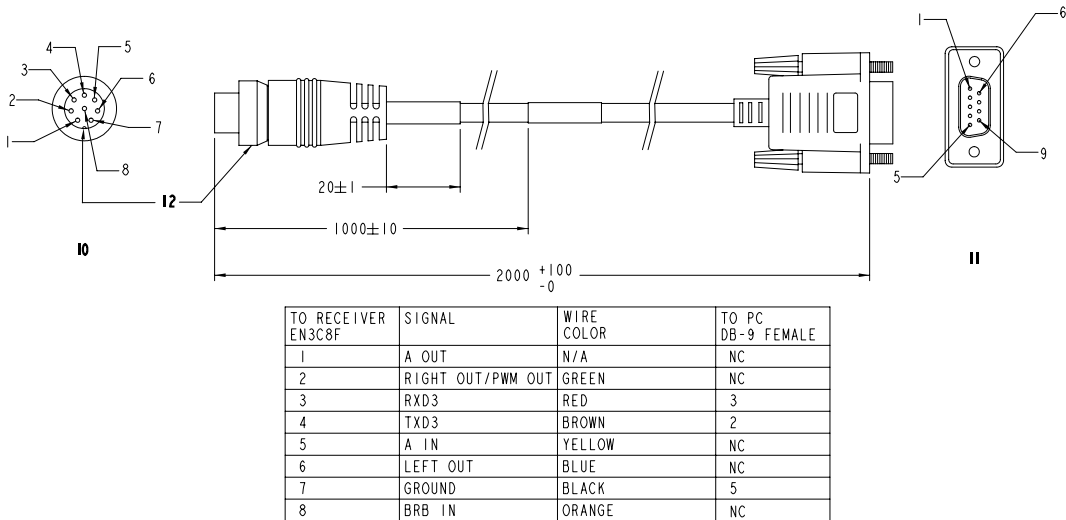

Reference	Description
10	8-pin Switchcraft EN3C8F connector
11	DB9S connector
12	Connector key



Figure 56: ProPak-LB*plus* 8-Pin Serial Cable

B.1 Overview

Static electricity is electrical charge stored in an electromagnetic field or on an insulating body. This charge can flow as soon as a low-impedance path to ground is established. Static-sensitive units can be permanently damaged by static discharge potentials of as little as 40 volts. Charges carried by the human body, which can be thousands of times higher than this 40 V threshold, can accumulate through as simple a mechanism as walking across non-conducting floor coverings such as carpet or tile. These charges may be stored on clothing, especially when the ambient air is dry, through friction between the body and/or various clothing layers. Synthetic materials accumulate higher charges than natural fibers. Electrostatic voltage levels on insulators may be very high, in the order of thousands of volts.

Various electrical and electronic components are vulnerable to electrostatic discharge (ESD). These include discrete components, hybrid devices, integrated circuits (ICs), and printed circuit boards (PCBs) assembled with these devices.

B.2 Handling ESD-Sensitive Devices

ESD-sensitive devices must only be handled in static-controlled locations. Some recommendations for such handling practices follow:

- Handling areas must be equipped with a grounded table, floor mats, and wrist strap.
- A relative humidity level must be maintained between 20% and 80% non-condensing.
- No ESD-sensitive board or component should be removed from its protective package, except in a static-controlled location.
- A static-controlled environment and correct static-control procedures are required at both repair stations and maintenance areas.
- ESD-sensitive devices must be handled only after personnel have grounded themselves via wrist straps and mats.
- Boards or components should never come in contact with clothing, because normal grounding cannot dissipate static charges on fabrics.
- A circuit board must be placed into an anti-static plastic clamshell before being removed from the work location and must remain in the clamshell until it arrives at a static-controlled repair/test center.
- Circuit boards must not be changed or moved needlessly. Handles may be provided on circuit boards for use in their removal and replacement; care should be taken to avoid contact with the connectors and components.
- On-site repair of ESD-sensitive equipment should not be undertaken except to restore service in an emergency where spare boards are not available. Under these circumstances repair station techniques must be observed. Under normal circumstances a faulty or suspect circuit board must be sent to a repair center having complete facilities, or to the manufacturer for exchange or repair.

- Where protective measures have not been installed, a suitable alternative would be the use of a Portable Field Service Grounding Kit (for example, 3M Kit #8501 or #8507). This consists of a portable mat and wrist strap which must be attached to a suitable ground.
- A circuit board in a static-shielding bag or clamshell may be shipped or stored in a cardboard carton, but the carton must not enter a static-controlled area such as a grounded or dissipative bench top or repair zone. Do not place anything else inside the bag (for example, repair tags).
- Treat all PCBs and components as ESD sensitive. Assume that you will damage the PCB or component if you are not ESD conscious.
- Do not use torn or punctured static-shielding bags. A wire tag protruding through the bag could act as a "lightning rod", funneling the entire charge into the components inside the bag.
- Do not allow chargeable plastics, such as binders, within 0.6 m of unshielded PCBs.
- Do not allow a PCB to come within 0.3 m of a computer monitor.

B.3 Prime Static Accumulators

Table 30 provides some background information on static-accumulating materials.

Table 30: Static-Accumulating Materials

Work Surfaces	<ul style="list-style-type: none"> • formica (waxed or highly resistive) • finished wood • synthetic mats • writing materials, note pads, and so on
Floors	<ul style="list-style-type: none"> • wax-finished • vinyl
Clothes	<ul style="list-style-type: none"> • common cleanroom smocks • personal garments (all textiles) • non-conductive shoes
Chairs	<ul style="list-style-type: none"> • finished wood • vinyl • fiberglass
Packing and handling	<ul style="list-style-type: none"> • common polyethylene bags, wraps, envelopes, and bubble pack • pack foam • common plastic trays and tote boxes
Assembly, cleaning, and repair areas	<ul style="list-style-type: none"> • spray cleaners • common solder sucker • common soldering irons • common solvent brushes (synthetic bristles) • cleaning, drying and temperature chambers

B.4 Handling Printed Circuit Boards

ESD damage to unprotected sensitive devices may occur at any time. ESD events can occur far below the threshold of human sensitivity. Follow this sequence when it becomes necessary to install or remove a circuit board:

1. After you are connected to the grounded wrist strap, remove the circuit board from the frame and place it on a static-controlled surface (grounded floor or table mat).
2. Remove the replacement circuit board from the static-shielding bag or clamshell and insert it into the equipment.
3. Place the original board into the shielding bag or clamshell and seal it with a label.
4. Do not put repair tags inside the shielding bag or clamshell.
5. Disconnect the wrist strap.

The following are a list of the replacement parts available for your NovAtel GPS receiver. Should you require assistance or need to order additional components, please contact your local NovAtel dealer or Customer Service representative.

C.1 FlexPak

Part Description	NovAtel Part
12V power adapter cable (<i>Page 131</i>)	01017374
13-pin Deutsch to DB9 null modem serial cable (<i>Page 132</i>)	01017375
13-pin Deutsch to DB9 straight through cable (<i>Page 133</i>)	01017518
13-pin Deutsch to USB connector cable (<i>Page 134</i>)	01017359

C.2 ProPak-G2plus

Part Description	NovAtel Part
I/O strobe cable (<i>Figure 50 on Page 141</i>)	60723065
Straight through serial data cable (<i>Figure 49 on Page 140</i>)	60723066
Null modem serial data cable (<i>Figure 48 on Page 139</i>)	60323062
Power cable: LEMO 4-pin socket to 12V power outlet plug (<i>Figure 47 on Page 138</i>)	01017023

C.3 ProPak-LBplus

Part Description	NovAtel Part
12V power adapter cable (<i>Page 147</i>)	60723064
6-pin Switchcraft to DB9 serial cable (<i>Page 148</i>)	60723061
7-pin Switchcraft to DB9 serial cable (<i>Page 149</i>)	60723062
8-pin Switchcraft to DB9 serial cable (<i>Page 150</i>)	60723063

C.4 Accessories

Part Description		NovAtel Part
OEM4 Family Compact Disc with PC utilities		01017190
OEM4 Family User Manual Volume 1, Installation and Operation		OM-20000046
OEM4 Family User Manual Volume 2, Commands and Log Reference		OM-20000047
Optional NovAtel GPS Antennas:	Model 702 (L1/L2)	GPS-702
	Model 701 (L1-only)	GPS-701
	Model 600-LB (L1/L2/L-Band)	GPS-600-LB
	Model 533 (L1/L2)	GPS-533
	Model 532 (L1/L2)	GPS-532
Optional RF Antenna Cable:	5 meters	C006
	15 meters	C016
	30 meters	C032
	22 cm interconnect adapter cable	GPS-C002

C.5 Manufacturer's Part Numbers

The following original manufacturer's part numbers, for the FlexPak, ProPak-G2*plus* and ProPak-LB*plus* cables, are provided for information only and are not available from NovAtel as separate parts:

C.5.1 FlexPak

Part Description	Deutsch Part
3-pin plug connector on 12V power adapter cable (<i>Page 131</i>)	59064 - 09 - 98SN
13-pin plug connector on serial cables (<i>Page 132 - Page 134</i>)	59064 - 11 - 35SF

C.5.2 ProPak-G2*plus*

Part Description	LEMO Part
4-pin socket connector on power cable (<i>Figure 47 on Page 138</i>)	FGG.0B.304.CLAD52Z

C.5.3 ProPak-LB*plus*

Part Description	Switchcraft Part
2-pin socket connector on 12V power adapter cable (<i>Page 147</i>)	EN3C2F
6-pin socket connector on serial cable (<i>Page 148</i>)	EN3C6F
7-pin socket connector on serial cable (<i>Page 149</i>)	EN3C7F
8-pin socket connector on serial cable (<i>Page 150</i>)	EN3C8F

This appendix gives some details on OEM4 family products that are now obsolete. Obsolete products are still supported but are not available. In a future hardware revision, these models will no longer be supported.

D.1 Installation and Setup

The voltage input range for each GPSCard type is given in the table below.

Table 31: Voltage Input Ranges for GPSCards

GPSCard	Power Input Range
OEM4	+6 to +18 VDC
Euro4	+5.0 \pm 0.125 VDC

All PowerPak and ProPak enclosures provide a TNC female connector, which can be connected to the antenna directly with any of NovAtel's coaxial cables. For the GPSCards, an interconnect adapter cable is required to convert the TNC male end of the coaxial cable to the card's specific RF input connector type, which is given in the table below.

Table 32: GPSCard RF Input Connectors

GPSCard	RF Input Connector
OEM4	MMCX female
Euro4	SMB right-angle male

Connect the power supply, set to the voltage given in the table below, to the wiring harness.

Table 33: GPSCard Power Inputs

GPSCard	Power Input Range
OEM4	+6 to +18 VDC
Euro4	+5.0 \pm 0.125 VDC

For a PowerPak or ProPak enclosure, connect the power supply to the port described in *Table 34 on Page 157*.

Table 34: Enclosure Power Inputs

Enclosure	Power Input Port	Power Input Range
ProPak-G2	4-pin LEMO male connector	+7 to +18 VDC
PowerPak-4	Standard 2.1 mm center-positive receptacle labelled 6-18V DC	+6 to +18 VDC
PowerPak-4E	Standard 2.1 mm center-positive receptacle labelled 10 - 36V DC	+10 to +36 VDC
ProPak-4E	4-pin LEMO male connector	+10 to +36 VDC

Table 35: Default Serial Port Configurations

Receiver	COM1	COM2	COM3
OEM4	RS-232	RS-232	LVTTTL
Euro4	RS-232	RS-232	RS-232
ProPak-G2	See Tables 39 and 40 on Page 160 for the DB-9 and LEMO versions respectively		
PowerPak-4	RS-232	RS-232	RS-232
PowerPak-4E	RS-232	RS-232	Not available
ProPak-4E	RS-232	RS-232	Not available

Table 36: PowerPak-4 Status Indicators

Indicator	Indicator Color	Status
VALID POSITION	Red	Hardware error
	Green	Valid position computed
STATUS	Red, Yellow, or Both	The GPSCard is not working properly
	Flashing Green	The GPSCard is working properly
PWR	Red	The receiver is powered

Table 37: PowerPak-4E Status Indicators

Indicator	Indicator Color	Status
VALID POSITION	Red	Hardware error
	Green	Valid position computed
POWER	Red	The receiver is powered

Table 38: ProPak-G2 Status Indicators

Indicator	Indicator Color	Status
COM1	Green	Data is being transmitted from COM1
	Red	Data is being received on COM1
COM2	Green	Data is being transmitted from COM2
	Red	Data is being received on COM2

D.2 ProPak-G2

- ☒ There are two versions of the ProPak-G2. One version has DB-9 connectors and the other uses LEMO-brand connectors. Unless otherwise indicated, the information given in this section applies to both versions.

INPUT/OUTPUT CONNECTORS	
Antenna Input	TNC female jack, 50 Ω nominal impedance +4.25 to +5.25 VDC, 90 mA max (output from ProPak to antenna/LNA)
PWR	4-pin LEMO connector +7 to +18 VDC at 2.8 W (typical)
DB-9 Version	
COM1	DB9P connector
COM2	DB9P connector
AUX	DB9P connector
I/O	DB9S connector
LEMO Version	
COM1	10-pin LEMO connector
COM2	10-pin LEMO connector
PHYSICAL	
Size	185 x 160 x 71 mm
Weight	1.0 kg maximum (including OEM4-G2 GPSCard)
ENVIRONMENTAL	
Operating Temperature	-40° C to +75° C
Storage Temperature	-45°C to +95°C
Humidity	Not to exceed 95% non-condensing

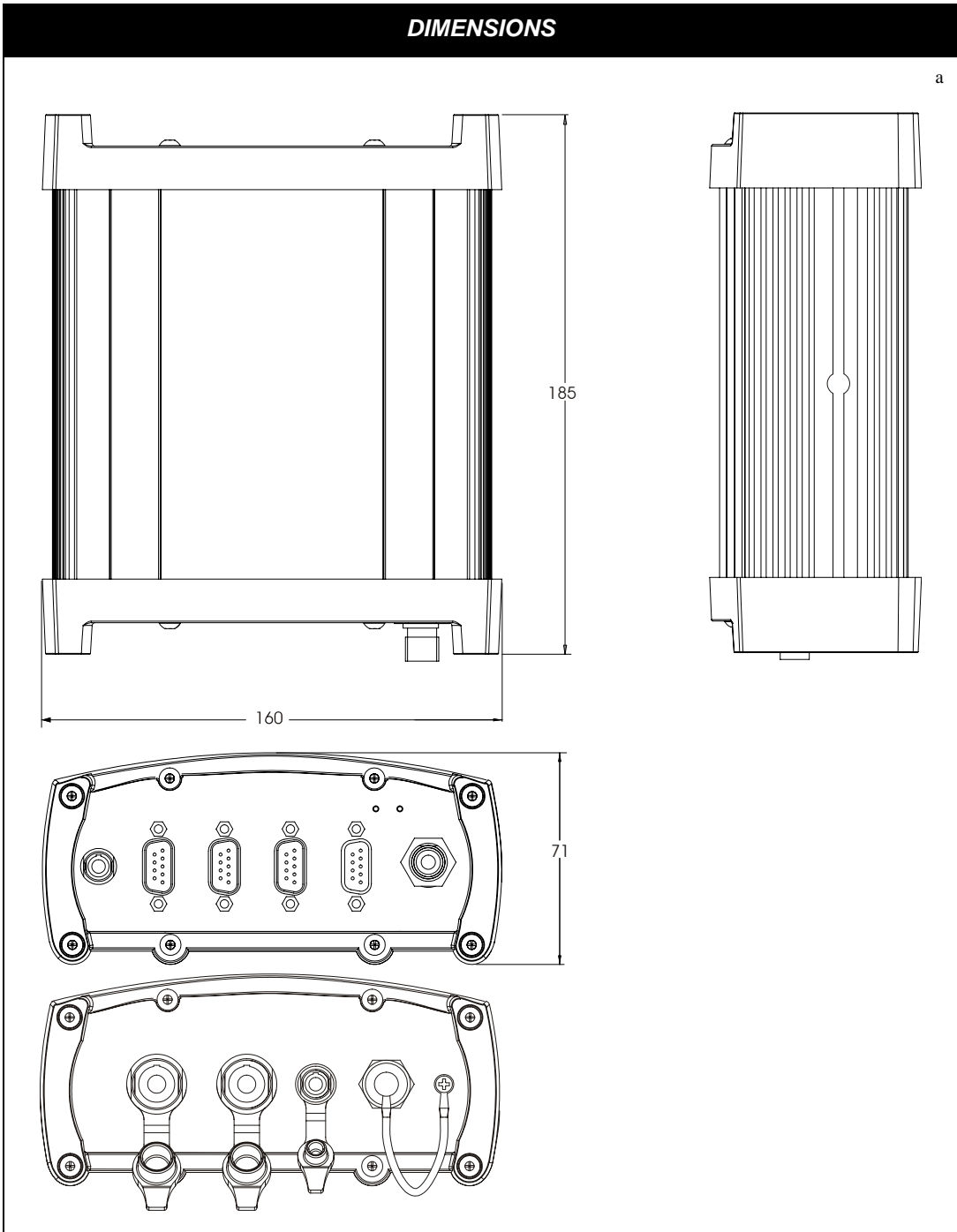

a. All dimension are in millimeters, please use *Unit Conversions* section of the *GPS+ Reference Manual* for conversion to imperial measurements.

D.2.1 Port Pin-Outs

Table 39: ProPak-G2 (DB-9 Version) Serial Port Pin-Out Descriptions

Connector Pin No.	COM1		COM2	AUX	
	RS232	RS422	RS232 Only	RS232	RS422
1	N/C	N/C	N/C	N/C	N/C
2	RXD1	RXD1(+)	RXD2	RXD3	RXD3(+)
3	TXD1	TXD1(+)	TXD2	TXD3	TXD3(+)
4	N/C	N/C	N/C	POUT	POUT
5	GND	GND	GND	GND	GND
6	N/C	N/C	N/C	N/C	N/C
7	RTS1	TXD1(-)	RTS2	RTS3	TXD3(-)
8	CTS1	RXD1(-)	CTS2	CTS3	RXD3(-)
9	N/C	N/C	N/C	N/C	N/C

Table 40: ProPak-G2 (LEMO Version) Serial Port Pin-Out Descriptions

Connector Pin No.	COM1/COM3		COM2
	RS232	RS422	RS232 Only
1	RTS3	RTS3	N/C
2	RXD1	RXD1(+)	RXD2
3	TXD1	TXD1(+)	TXD2
4	GND	GND	GND
5	GND	GND	GND
6	RXD3	RXD3	Event1
7	RTS1	TXD1(-)	RTS2
8	CTS1	RXD1(-)	CTS2
9	POUT	POUT	POUT
10	TXD3	TXD3	1PPS

Table 41: ProPak-G2 (DB-9 Version) I/O Port Pin-Out Descriptions

Connector Pin No.	Signal Name	Signal Descriptions
1	VARF	Variable frequency out
2	PPS	Pulse per second
3	N/C	Not connected
4	Event1	Mark 1 input
5	PV	Valid position available
6	N/C	Not connected
7	N/C	Not connected
8	GND	Digital ground
9	GND	Digital ground

☒ For strobe signal descriptions, please see *Section 3.3.1, Strokes on Page 36*.

D.2.2 Cables

D.2.2.1 12 V Power Adapter Cable (NovAtel part number 01017023)

The power adapter cable supplied with the ProPak-G2, see *Figure 57*, provides a convenient means for supplying +12 VDC.

Input is provided through a standard 12 V power outlet. The output from the power adapter utilizes a 4-pin LEMO connector and plugs directly into the *PWR* input located on the back panel of the ProPak-G2.

For alternate power sources please see *Section 3.3.1 on Page 36*.

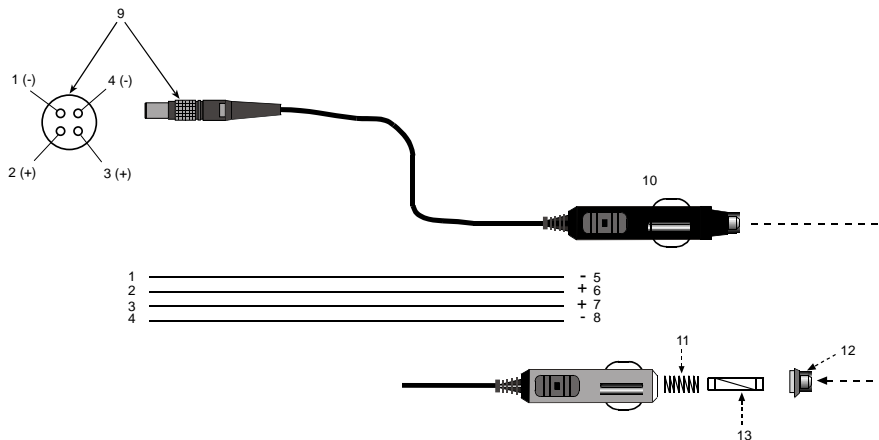

Reference	Description	Reference	Description
1	Black	5	Ground
2	Red	6	+7 to +18 VDC
3	Orange	7	+7 to +18 VDC
4	Brown	8	Ground
9	Connector key marking	12	Universal tip
10	12 V adapter	13	3 Amp slow-blow fuse
11	Spring		



Figure 57: ProPak-G2 Power Cable

D.2.2.2 Y-Type Null Modem Cable for DB-9 Version (NovAtel part number 60715062)

This cable supplied with the DB-9 version of the ProPak-G2, see *Figure 58*, provides an easy means of communications with a PC. The cable is equipped with a 9-pin connector at the receiver end which can be plugged into the *COM1*, *COM2*, or *AUX* port. At the PC end, both a 9-pin and a 25-pin connector are provided to accommodate most PC serial (RS232) communication ports.

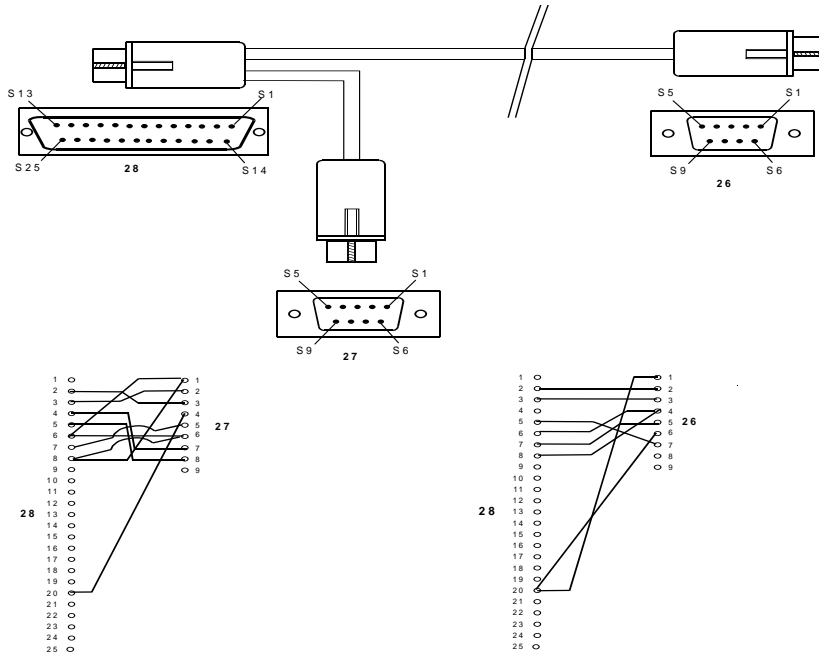

Wiring Table:

Connector	Pin Number						
From DB25S (28)	2	3	4	5	6 & 8	7	20
To DB9S (26)	2	3	8	7	4	5	1 & 6
To DB9S (27)	3	2	7	8	1 & 6	5	4

Reference	Description	Reference	Description
26	DB9S (Female)	28	DB25S (Female)
27	DB9S (Female)		



Figure 58: ProPak-G2 (DB-9 Version) Y-Type Null Modem Cable

D.2.2.3 Straight Serial Cable for DB-9 Version (NovAtel part number 60723066)

This cable can be used to connect the DB-9 version of the ProPak-G2 to a modem or radio transmitter to propagate differential corrections. The cable is equipped with a female DB9 connector at the receiver end. The male DB9 connector at the other end is provided to plug into your user-supplied equipment (please refer to your modem or radio transmitter user guide for more information on its connectors). The cable is approximately 2 m in length. See *Figure 59*.

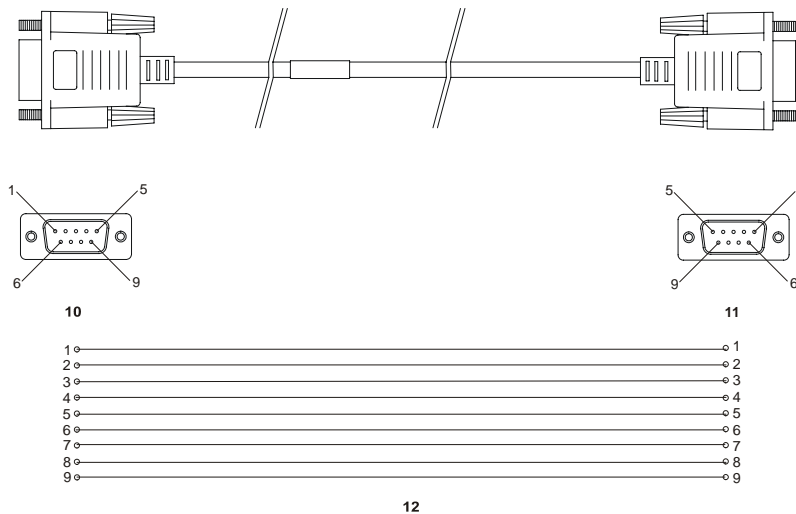

Reference	Description	Reference	Description
10	DB9P (male) connector	12	9-conductor cable
11	DB9S (female) connector		



Figure 59: ProPak-G2 (DB-9 Version) Straight Serial Cable

D.2.2.4 I/O Strobe Port Cable for DB-9 Version (NovAtel part number 60723065)

The strobe lines on the DB-9 version of the ProPak-G2 can be accessed by inserting the male DB9 connector of the I/O strobe port cable into the I/O port. The other end of this cable is provided without a connector to provide flexibility. The jacket insulation is cut away slightly from the end but the insulation on each wire is intact. The cable is approximately 2 m in length. See *Figure 60*.

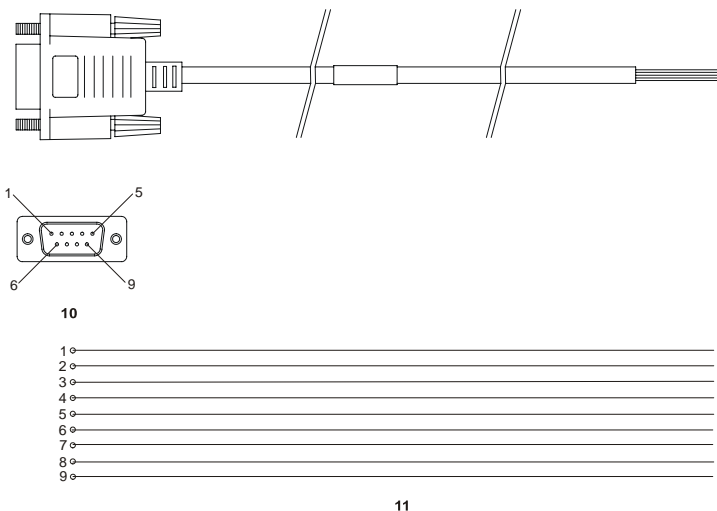

Wiring Table:

I/O Port Pin	I/O Port Signal	I/O Port Cable Wire Color	I/O Port Pin	I/O Port Signal	I/O Port Cable Wire Color
1	VARF	Black	6	Reserved	Green
2	PPS	Brown	7	Reserved	Blue
3	Reserved	Red	8	GND	Violet
4	Event1	Orange	9	GND	White/Grey
5	PV	Yellow			

Reference	Description	Reference	Description
10	DB9S (male) connector	11	9-conductor cable



Figure 60: ProPak-G2 (DB-9 Version) I/O Strobe Port Cable

D.2.2.5 Null Modem Cable for LEMO Version (NovAtel Part Number 403-0-0036)

The LEMO version of the ProPak-G2 includes a null modem cable, which provides an easy means of communications with a PC. The cable is equipped with a 10-pin LEMO connector at the receiver end which can be plugged into the *COM1* or *COM2* port. At the PC end, a DB-9 connector is provided to accommodate most PC serial (RS232) communication ports.

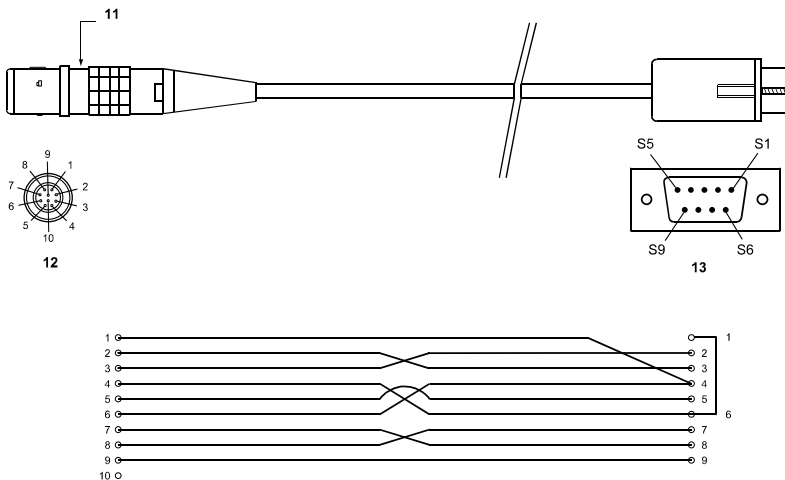

Reference	Description	Reference	Description
1	Brown	8	Violet
2	Black	9	Grey
3	Red	10	White (not used)
4	Orange	11	Connector key marking
5	Yellow	12	10-pin LEMO connector
6	Green	13	DB9S (female) connector
7	Blue		



Figure 61: ProPak-G2 (LEMO Version) Null Modem Cable

D.2.2.6 Straight Serial Cable for LEMO Version (NovAtel Part Number 403-0-0037)

This cable can be used to connect the LEMO version of the ProPak-G2 to a modem or radio transmitter to propagate differential corrections. The cable is equipped with a 10-pin LEMO connector at the receiver end that should ideally be plugged into COM2 on the receiver. The male DB-9 connector at the other end is provided to plug into your user-supplied equipment (please refer to your modem or radio transmitter user guide for more information on its connectors). The cable is approximately 2 m in length.

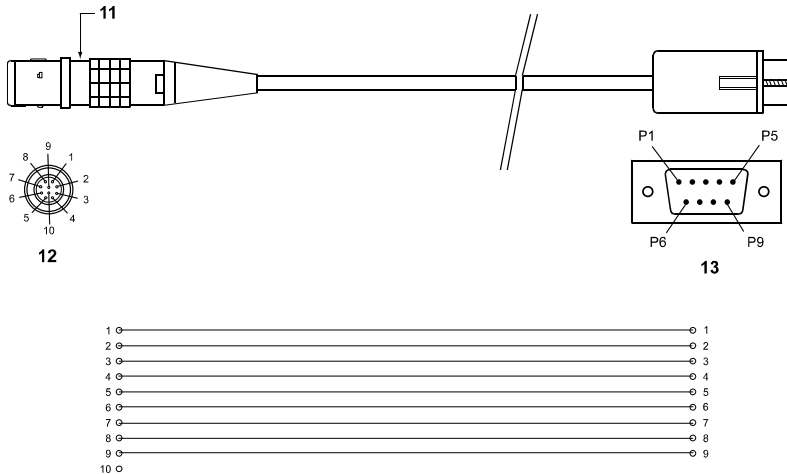

Reference	Description	Reference	Description
1	Brown	8	Violet
2	Black	9	Grey
3	Red	10	White (not used)
4	Orange	11	Connector key marking
5	Yellow	12	10-pin LEMO connector
6	Green	13	DB9P (male) connector
7	Blue		



Figure 62: ProPak-G2 (LEMO Version) Straight Serial Cable

D.3 OEM4 GPSCard

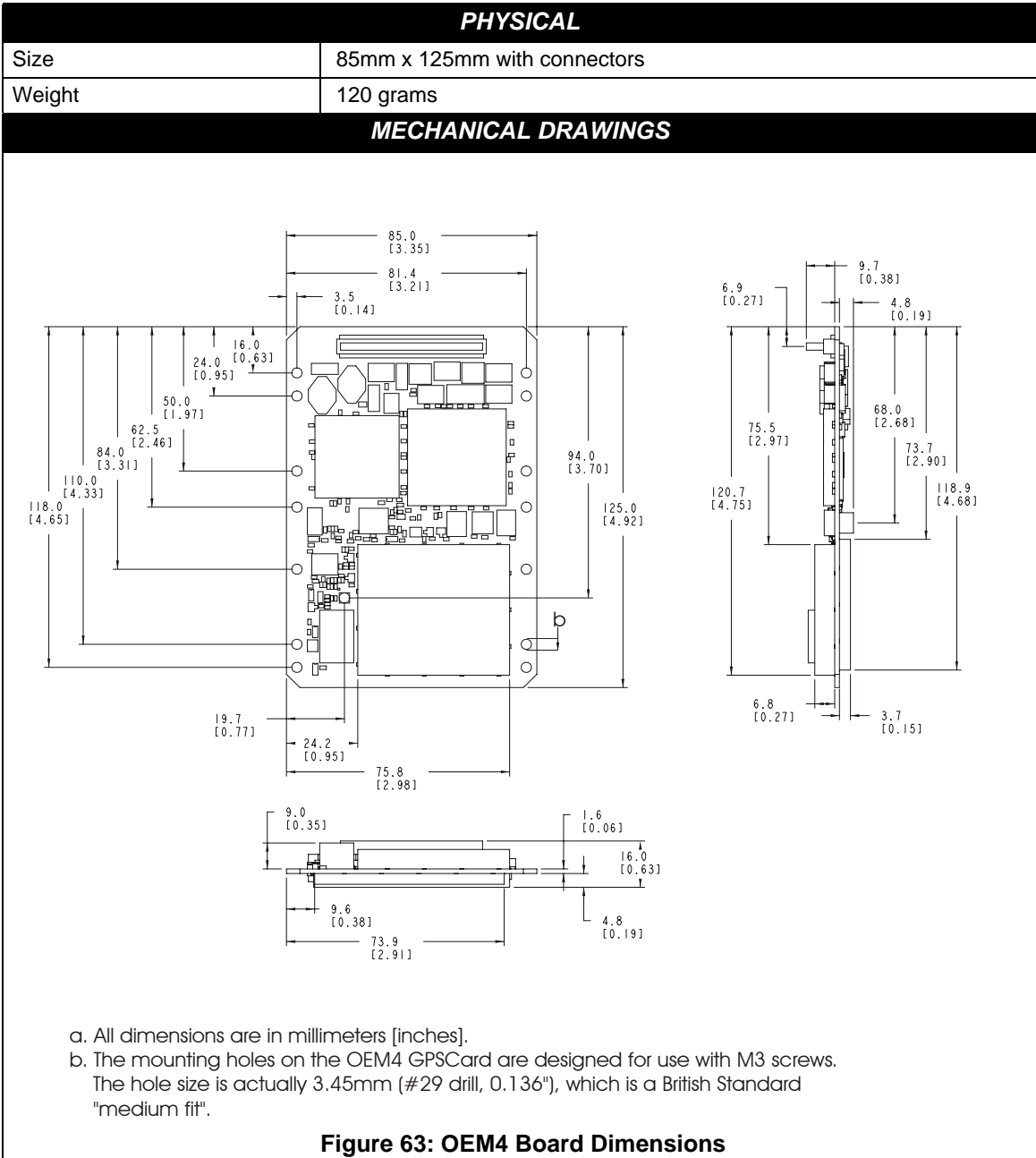

ENVIRONMENTAL	
Operating Temperature	-40°C to +85°C
Storage Temperature	-45°C to +95°C
Humidity	Not to exceed 95% non-condensing
POWER REQUIREMENTS	
Voltage	+6 to +18 VDC
Allowable Input Voltage Ripple	100 mV p-p (max.)
Power consumption	2.7 W (typical)
RF INPUT / LNA POWER OUTPUT	
Antenna Connector	MMCX connector, 50 Ω nominal impedance
RF Input Frequencies	1575.42 MHz (L1), 1227.60 MHz (L2)
LNA Power	
Internal (Output from card, default)	+4.50 to +5.25 VDC @ 0 - 100 mA
External (Optional Input)	+12 to +30 VDC, 100 mA max. (user-supplied)

INPUT/OUTPUT DATA INTERFACE**COM1 AND COM2**

Electrical format	RS232 (Can be factory configured for LVTTTL operation)
Bit rate^a	300, 1200, 4800, 9600 (default), 19200, 57600, 115200, 230400 bps
Lead input	CTS (and DCD on COM2)
Lead output	RTS (and DTR on COM2)
Signals supported	TX, RX, RTS, CTS, DTR, DCD (DTR and DCD are on COM2 only)

COM3

Electrical format	LVTTTL
Bit rate^a	300, 1200, 4800, 9600 (default), 19200, 57600, 115200, 230400 bps
Lead input	CTS
Lead output	RTS
Signals supported	TX, RX, RTS, CTS

- a. Baud rates higher than 115,200 bps are not supported by standard PC hardware. Special PC hardware is required for higher rates, including 230,400 bps.

INPUT/OUTPUT STROBES	
MSR (Measure Output)	Normally high, active low where the pulse width is 1 ms. The falling edge is the receiver measurement strobe.
Event1 (Mark 1 Input)	An input mark (negative pulse > 55 ns), time tags output log data to the time of the falling edge of the mark input pulse.
PV (Position Valid)	Indicates a valid GPS position solution is available. A high level indicates a valid solution or that the FIX POSITION command has been set (refer to the FIX POSITION command in user manual <i>Volume 2</i> of this manual set).
ERROR	Output for which a high level indicates an error.
STATUS_RED	Status output which is high or pulses to indicate that the OEM4 card is not working properly.
STATUS_GREEN	Status output which pulses to indicate that the OEM4 card is working properly.
PPS (Pulse Per Second)	A one-pulse-per-second time synchronization output. This is an active low pulse (1 ms ± 50 ns minimum) where the falling edge is synchronized to receiver calculated GPS time.
VARF (Variable Frequency)	A programmable variable frequency output ranging from 0 -20 MHz (refer to the FREQUENCYOUT command in <i>Volume 2</i> of this manual set). This is a normally high, active low pulse.
RESETOUT	Reset TTL signal output to external system; active low, 100 ms duration.
RESETIN	Reset TTL signal input from external system; active low, > 1 µs duration.
STROBE ELECTRICAL SPECIFICATIONS	
Output	Voltage: LVTTTL levels Low: minimum 0 VDC and maximum 0.55 VDC @ 24 mA High: minimum 2.4 VDC and maximum 3.6 VDC @ 8 mA
Input	Voltage: LVTTTL levels Low: minimum 0 VDC and maximum 0.8 VDC High: minimum 2.0 VDC and maximum 5.5 VDC

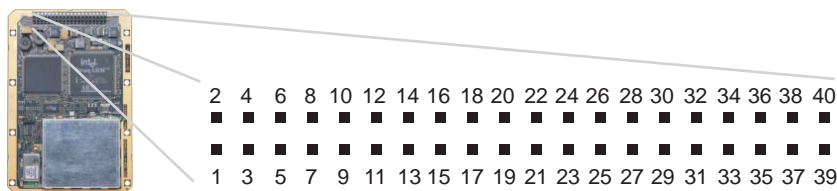

Figure 64: Top-view of 40-Pin Connector on the OEM4

Signal	Descriptions	Pin
V _{IN}	Voltage In, +6 to +18 VDC	1
PV	Output indicates 'good solution' or valid GPS position when high.	2
*	Reserved	3
GND	Digital Ground	4
*	Reserved	5
GND	Digital Ground	6
PPS	Normally high, active low output pulse is 1 ms wide @ 1 Hz. Falling edge is used as the reference.	7
GND	Digital Ground	8
VARF	Variable frequency out	9
GND	Digital Ground	10
Event1	Normally high, active low input pulse must exceed 55 ns in duration. The falling edge is the reference. LVTTTL (contact closure compatible)	11
GND	Digital Ground	12
STATUS RED	Indicates the OEM4 card is not working properly when high or pulsing.	13
CTS1	Clear to Send for COM 1 input	14
TXD1	Transmitted Data for COM 1 output	15
RTS1	Request to Send for COM 1 output	16
RXD1	Received Data for COM 1 input	17
CTS3	Clear to Send for COM 3 input	18
TXD3	Transmitted Data for COM 3 output	19
DCD2	Data Carrier Detected for COM 2 input	20
RXD3	Received Data for COM 3 input	21
RTS3	Request to Send for COM 3 output	22
DTR2	Data Terminal Ready for COM 2 output	23
CTS2	Clear to Send for COM 2 input	24
TXD2	Transmitted Data for COM 2 output	25
RTS2	Request to Send for COM 2 output	26
RXD2	Received Data for COM 2 input	27
STATUS GREEN	Indicates the OEM4 card is working properly when pulsing at 1 Hz.	28
GPIO_USER0	Reserved. 10 kΩ pull-down resistor.	29
GPIO_USER1	Reserved. 10 kΩ pull-down resistor.	30
GPIO_USER2	Reserved. 10 kΩ pull-down resistor.	31

Continued on Page 173

MSR	Normally high, active low pulse is 1 ms \pm 50 ns wide. Falling edge is used as the reference.	32
$\overline{\text{RESETIN}}$	Reset TTL signal input from external system; active low.	33
GPAI	General purpose analog input (see the RXHWLEVELS log in <i>Volume 2</i> of this manual set).	34
$\overline{\text{RESETOUT}}$	Reset TTL signal output to external system; active low.	35
GND	Digital Ground	36
GPIO_FR	Reserved. 10 k Ω pull-up resistor.	37
ERROR	Indicates fatal error when high	38
*	Reserved.	39
LNA_PWR	Optional external power to antenna other than a standard NovAtel GPSAntenna (see the ANTENNAPOWER command in <i>Volume 2</i> of this manual set)	40

☒ To create a common ground, tie together all digital grounds (GND) with the ground of the power supply.

D.4 Euro4 GPSCard

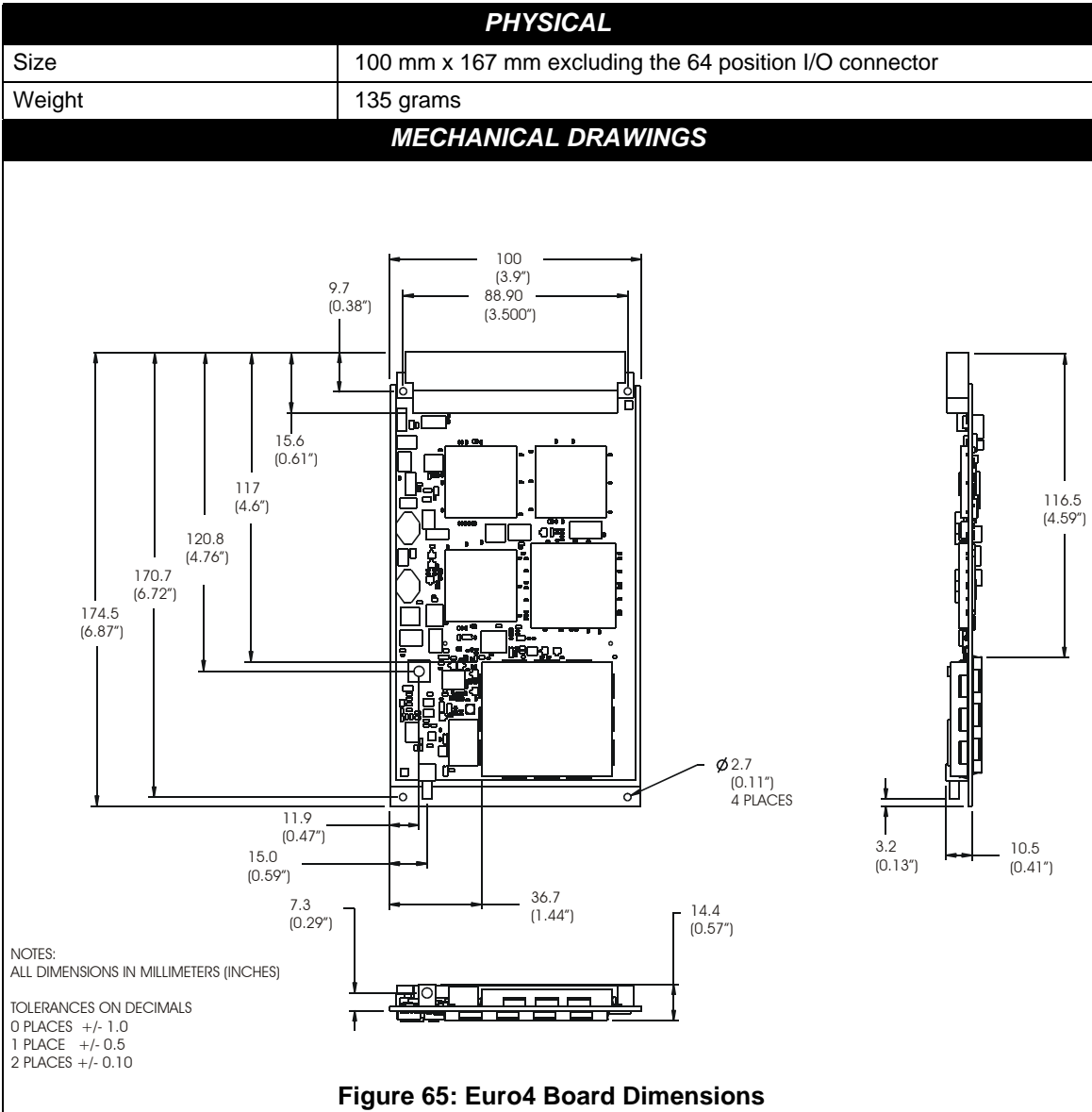

ENVIRONMENTAL	
Operating Temperature	-40°C to +85°C
Storage Temperature	-45°C to +95°C
Humidity	Not to exceed 95% non-condensing
POWER REQUIREMENTS	
Voltage	+5.0 ± 0.125 VDC
Allowable Input Voltage Ripple	50 mV p-p (max.)
Power consumption	2.3 W (typical)
RF INPUT / LNA POWER OUTPUT	
Antenna Connector	SMB right-angle male jack, 50 Ω nominal impedance
RF Input Frequencies	1575.42 MHz (L1), 1227.60 MHz (L2)
LNA Power	
Internal (Output from card, default)	+4.50 to +5.25 VDC @ 0 - 100 mA
External (Optional input)	+12 to +30 VDC, 100 mA max. (user-supplied)
EXTERNAL OSCILLATOR INPUT	
Connector	SMB straight (vertical) male jack
External Clock Input	Frequency: 5 MHz or 10 MHz Input Impedance: 50 Ω nominal Input VSWR:2.0:1 Signal Level: 0 dBm minimum to +13.0 dBm maximum Frequency Stability: ± 0.5 ppm maximum Wave Shape: Sinusoidal

INPUT/OUTPUT DATA INTERFACE**COM1, COM2 AND COM3**

Electrical format	RS232 (Can be factory configured for LVTTTL or RS422 operation)
Bit rate^a	300, 1200, 4800, 9600 (default), 19200, 57600, 115200, 230400 bps
Lead input	CTS (and DCD on COM2)
Lead output	RTS (and DTR on COM2)
Signals supported	TX, RX, RTS, CTS, DTR, DCD (DTR and DCD are on COM2 only)

- a. Baud rates higher than 115,200 bps are not supported by standard PC hardware. Special PC hardware is required for higher rates, including 230,400 bps.

INPUT/OUTPUT STROBES

MSR (Measure Output)	Normally high, active low where the pulse width is 1 ms. The falling edge is the receiver measurement strobe.
Event1 (Mark1 Input)	An input mark (negative pulse > 55 ns), time tags output log data to the time of the falling edge of the mark input pulse.
PV (Position Valid)	Output indicates a 'good solution' or a valid GPS solution when high.
ERROR	Output that Indicates fatal error warning when high.
STATUS_RED	Status output which is high or pulses to indicate that the OEM4 card is not working properly.
STATUS_GREEN	Status output which pulses to indicate that the OEM4 card is working properly.
PPS (Pulse Per Second)	Normally high, active low pulse is 1 ms wide @ 1 Hz. Falling edge is used as the reference.
VARF (Variable Frequency)	A programmable variable frequency output ranging from 0 - 20 MHz (refer to the FREQUENCYOUT command in <i>Volume 2</i> of this manual set). This is a normally high, active low pulse.
RESETOUT	Reset TTL signal output to external system; active high.
RESETIN	Reset TTL signal input from external system; active low, > 1 μ s duration.

STROBE ELECTRICAL SPECIFICATIONS

Output	Voltage:	LVTTTL levels
	Low:	minimum 0 VDC and maximum 0.55 VDC @ 24 mA
	High:	minimum 2.4 VDC and maximum 3.6 VDC @ 8 mA
Input	Voltage:	LVTTTL levels
	Low:	minimum 0 VDC and maximum 0.8 VDC
	High:	minimum 2.0 VDC and maximum 5.5 VDC

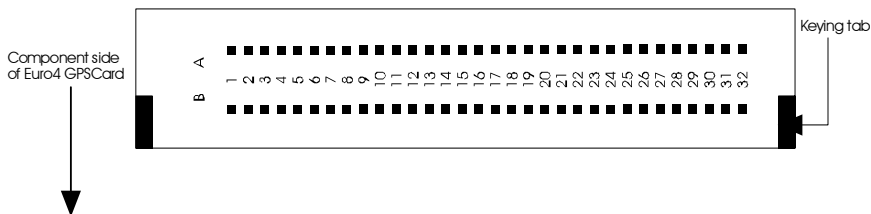

Figure 66: Front-view of 64-Pin Connector on the Euro4

Signal	Descriptions	Row A Pin
GND	Digital Ground	1
5VIN	Voltage in, 5 VDC ± 0.125 VDC	2
Reserved for future use.		3
GND	Digital Ground	4
GPIO_USER0	Reserved. 10 kΩ pull-down resistor.	5
GPIO_USER1	Reserved. 10 kΩ pull-down resistor.	6
GND	Digital Ground	7
RTS1(-)/NC	COM1 Request to send (-) for RS422 / not connected for RS232 and LVTTTL	8
TXD1(+)/TXD1	COM1 Transmitted data (+) for RS422 / transmitted data for RS232 and LVTTTL	9
RXD1(+)/RXD1	COM1 Received data (+) for RS422 / received data for RS232 and LVTTTL	10
RXD1(-)/NC	COM1 Received data (-) for RS422 / not connected for RS232 and LVTTTL	11
RTS3(-)/NC	COM3 Request to send (-) for RS422 / not connected for RS232 and LVTTTL	12
TXD3(+)/TXD3	COM3 Transmitted data (+) for RS422 / transmitted data for RS232 and LVTTTL	13
RXD3(+)/RXD3	COM3 Received data (+) for RS422 / received data for RS232 and LVTTTL	14
GND	Digital Ground	15
RTS2(-)/DTR2	COM2 Request to send (-) for RS422 / data terminal ready for RS232 and LVTTTL	16
TXD2(+)/TXD2	COM2 Transmitted data (+) for RS422 / transmitted data for RS232 and LVTTTL	17
RXD2(+)/RXD2	COM2 Received data (+) for RS422 / received data for RS232 and LVTTTL	18
RXD2(-)/DCD2	COM2 Received data (-) for RS422 / data carrier detected for RS232 and LVTTTL	19
TXD3(-)/NC	COM3 Transmitted data (-) for RS422 / not connected for RS232 and LVTTTL	20
CTS3(-)/NC	COM3 Clear to send (-) for RS422 / not connected for RS232 and LVTTTL	21
RXD3(-)/NC	COM3 Received data (-) for RS422 / not connected for RS232 and LVTTTL	22
GND	Digital Ground	23-31
GPIO_FR	Reserved. 10 kΩ pull-up resistor.	32

Signal	Descriptions	Row B Pin
GND	Digital Ground	1
5VIN	Voltage in, 5 VDC ± 0.125 VDC	2
Reserved for future use.		3
LNA_PWR	Optional external power to antenna other than a standard NovAtel GPSAntenna (see Section 3.3.5, External Antenna LNA Power (OEM4-G2 Only) on Page 40 and the ANTENNAPOWER command in Volume 2 of this manual set).	4

Continued on Page 178

STATUS_RED	Indicates the Euro4 is not working properly when high or pulsing	5
STATUS_GREEN	Indicates the Euro4 is working properly when pulsing at 1 Hz	6
Reserved for future use.		7
TXD1(-)/NC	COM1 transmitted data (-) for RS422 / not connected for RS232 and LVTTTL	8
CTS1(+)/CTS1	COM1 clear to send (+) for RS422 / clear to send for RS232 and LVTTTL	9
RTS1(+)/RTS1	COM1 request to send (+) for RS422 / request to send for RS232 and LVTTTL	10
CTS1(-)/NC	COM1 clear to send (-) for RS422 / not connected for RS232 and LVTTTL	11
GPAI	General purpose analog input (see the RXHWLEVELS log in <i>Volume 2</i> of this manual set).	12
CTS3(+)/CTS3	COM3 clear to send (+) for RS422 / clear to send for RS232 and LVTTTL	13
RTS3(+)/RTS3	COM3 request to send (+) for RS422 / request to send for RS232 and LVTTTL	14
ERROR	Indicates fatal error warning.	15
TXD2(-)/NC	COM2 transmitted data (-) for RS422 / not connected for RS232 and LVTTTL	16
CTS2(+)/CTS2	COM2 clear to send (+) for RS422 / clear to send for RS232 and LVTTTL	17
RTS2(+)/RTS2	COM2 request to send (+) for RS422 / request to send for RS232 and LVTTTL	18
CTS2(-)/NC	COM2 clear to send (-) for RS422 / not connected for RS232 and LVTTTL	19
Reserved for future use.		20
VARF	Variable frequency out	21
PPS	Normally high, active low pulse is 1 ms wide @ 1 Hz. Falling edge is used as the reference.	22
MSR	Normally high, active low pulse is 1 ms \pm 50 ns wide. Falling edge is used as the reference.	23
Event1	Normally high, active low pulse must exceed 55 ns in duration. The falling edge is the reference. LVTTTL (contact closure compatible).	24
PV	Output indicates a 'good solution' or a valid GPS solution when high.	25
GPIO_USER2	Reserved. 10 k Ω pull-down resistor.	26
Reserved for future use.		27
RESETIN	Reset TTL signal input from external system; active low.	28
RESETOUT	Reset TTL signal output to external system; active high.	29
GPIO_USER3	Reserved. 10 k Ω pull-down resistor.	30
Reserved for future use.		31
GPIO_USER4	Reserved. 10 k Ω pull-down resistor.	32

- For pins that can be configured as RS422, RS232 or LVTTTL, the signals are shown as RS422/RS232/LVTTTL. RS422 is balanced; there are two connections per signal indicated as (+) and (-).
- CTS, DCD and DSR are inputs while RTS and DTR are outputs.
- To create a common ground, tie together all digital grounds (GND) with the ground of the power supply.

D.5 PowerPak-4/PowerPak-4E

INPUT/OUTPUT CONNECTORS	
Antenna Input	TNC female jack, 50 Ω nominal impedance +4.25 to +5.25 VDC, 90 mA max (output from PowerPak to antenna/LNA)
Power	2.1 mm plug with screw-on retaining nut, centre positive
PowerPak-4	+6 to +18 VDC at 2.8 W typical
PowerPak-4E	+10 to +36 VDC at 3.3 W typical
COM1	DE9P connector
COM2	DE9P connector
COM3 (PowerPak-4 only)	DE9P connector
Strobes	DE9S connector
External Oscillator Input (PowerPak-4E only)	SMB straight (vertical) male jack Frequency: 5 MHz or 10 MHz Input Impedance: 50 Ω nominal Input VSWR: 2.0:1 Signal Level: 0 dBm minimum to +13.0 dBm maximum Frequency Stability: \pm 0.5 ppm maximum Wave Shape: Sinusoidal
PHYSICAL	
Size	208 x 111 x 47 mm
Weight	
PowerPak-4	800 g maximum (including OEM4 GPSCard)
PowerPak-4E	980 g maximum (including Euro4 GPSCard)
ENVIRONMENTAL	
Operating Temperature	-40°C to +75°C
Storage Temperature	-45°C to +95°C
Humidity	Not to exceed 95% non-condensing

DIMENSIONS

a

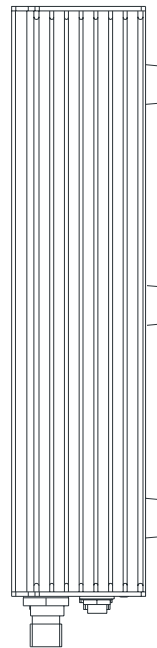
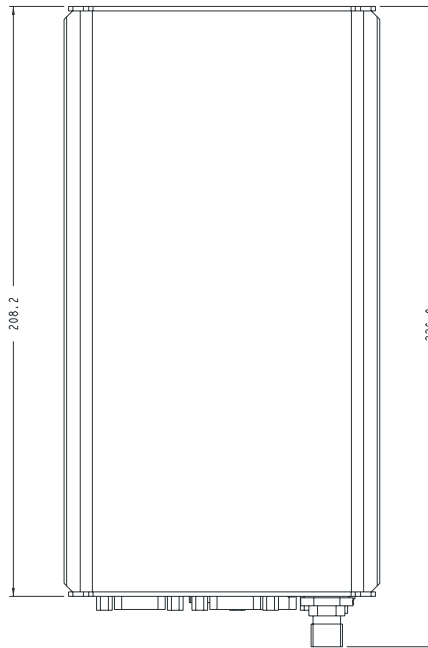
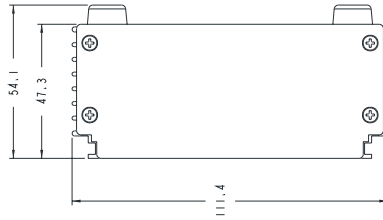

PowerPak-4:

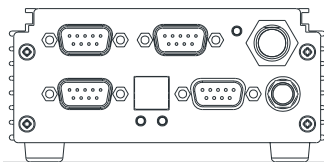

PowerPak-4E:

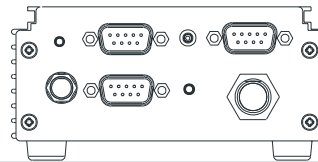

- a. All dimension are in millimeters, please use the *Unit Conversion* section of the *GPS+ Reference Manual* for conversion to imperial measurements.

D.5.1 Port Pin-Outs

Table 42: PowerPak Serial Port Pin-Out Descriptions

Connector Pin No.	COM1		COM2		COM3 (PowerPak-4 only)
	RS232	RS422	RS232	RS422	RS232 Only
1	N/C	RXD1(-)	DCD2	RXD2(-)	N/C
2	RXD1	RXD1(+)	RXD2	RXD2(+)	RXD3
3	TXD1	TXD1(+)	TXD2	TXD2(+)	TXD3
4	N/C	RTS1(-)	DTR2	RTS2(-)	N/C
5	GND	GND	GND	GND	GND
6	N/C	CTS1(-)	N/C	CTS2(-)	N/C
7	RTS1	RTS1(+)	RTS2	RTS2(+)	RTS3
8	CTS1	CTS1(+)	CTS2	CTS2(+)	CTS3
9	N/C	TXD1(-)	N/C	TXD2(-)	N/C

Table 43: PowerPak I/O Port Pin-Out Descriptions

Connector Pin No.	PowerPak-4E Signal Name	PowerPak-4 Signal Name	Signal Descriptions
1	VARF	VARF	Variable frequency out
2	PPS	PPS	Pulse per second
3	MSR	Reserved	Measure output Reserved for future use
4	Event1	Event1	Mark 1 input
5	PV	PV	Valid position available
6	GND	ERROR	Digital ground Error indicator
7	GND	Reserved	Digital ground Reserved for future use
8	GND	GND	Digital ground
9	GND	GND	Digital ground

☒ For strobe signal descriptions, please see *Section 3.3.1, Strokes on Page 36*.

D.5.2 Cables

D.5.2.1 12V Power Adapter Cable (NovAtel part number 01014989)

The power adapter cable supplied with the PowerPak, see *Figure 67*, provides a convenient means for supplying +12 VDC while operating in the field.

Input is provided through the standard 12V power outlet. The output from the power adapter utilizes a standard 2.1 mm plug where the center is a female contact (positive) and the outer jacket contact is negative and plugs directly into the power jack located on the front panel of the PowerPak.

For alternate power sources please see *Section 3.1.3 on Page 29*.

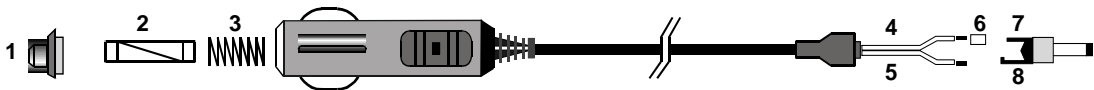

Reference	Description
1	Universal tip
2	Slow blow fuse
3	Spring
4	Positive line
5	Negative line (has text printed on it)
6	Shrinkable tubing
7	Positive
8	Negative



Figure 67: PowerPak Power Adapter

D.5.2.2 Y-Type Null Modem Cable (NovAtel part number 60715062)

This cable supplied with the PowerPak, see *Figure 68*, provides an easy means of communications with the receiver's RS232 port from a PC. The cable is equipped with a 9-pin connector at the PowerPak end which can be plugged into either COM1 or COM2. At the PC end, both a 9-pin and a 25-pin connector are provided to accommodate most PC serial (RS232) communication ports.

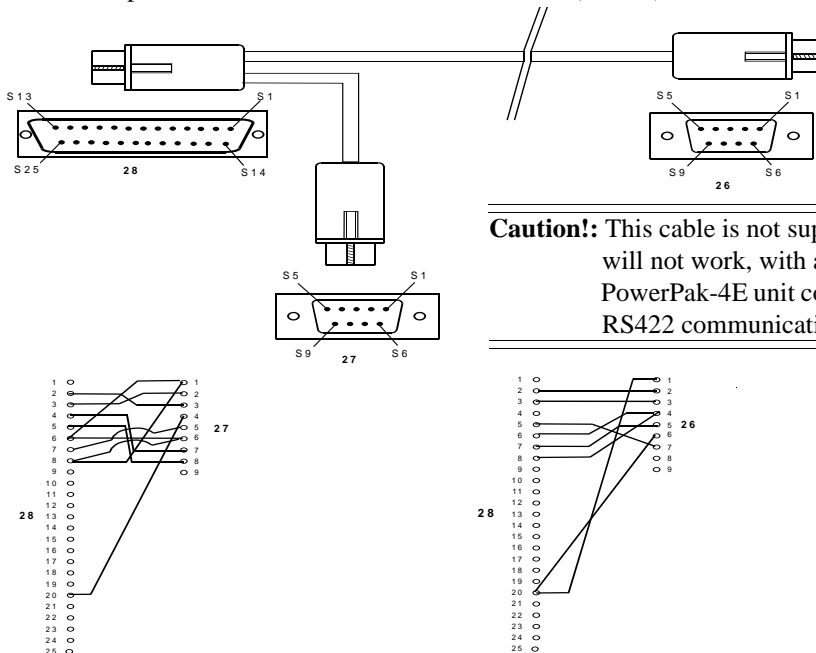

Caution!: This cable is not supplied, and will not work, with a PowerPak-4E unit configured for RS422 communication.

Wiring Table:

Connector	Pin Number						
From DB25S (28)	2	3	4	5	6 & 8	7	20
To DE9S (26)	2	3	8	7	4	5	1 & 6
To DE9S (27)	3	2	7	8	1 & 6	5	4

Reference	Description	Reference	Description
26	DE9S (Female)	28	DB25S (Female)
27	DE9S (Female)		



Figure 68: PowerPak Y-Type Null Modem Cable

D.6 ProPak-4E

INPUT/OUTPUT CONNECTORS	
Antenna Input	TNC female jack, 50 Ω nominal impedance +4.25 to +5.25 VDC, 90 mA max (output from ProPak-4E to antenna/LNA)
Power	4-pin LEMO +10 to +36 VDC continuous at 3.3 W typical
COM1	10-pin LEMO
COM2	10-pin LEMO
Strobes	8-pin LEMO
PHYSICAL	
Size	245 x 130 x 59 mm
Weight	1.2 kg maximum (including Euro4 GPSCard)
ENVIRONMENTAL	
Operating Temperature	-40° C to +65° C
Storage Temperature	-45°C to +95°C
Humidity	Not to exceed 95% non-condensing

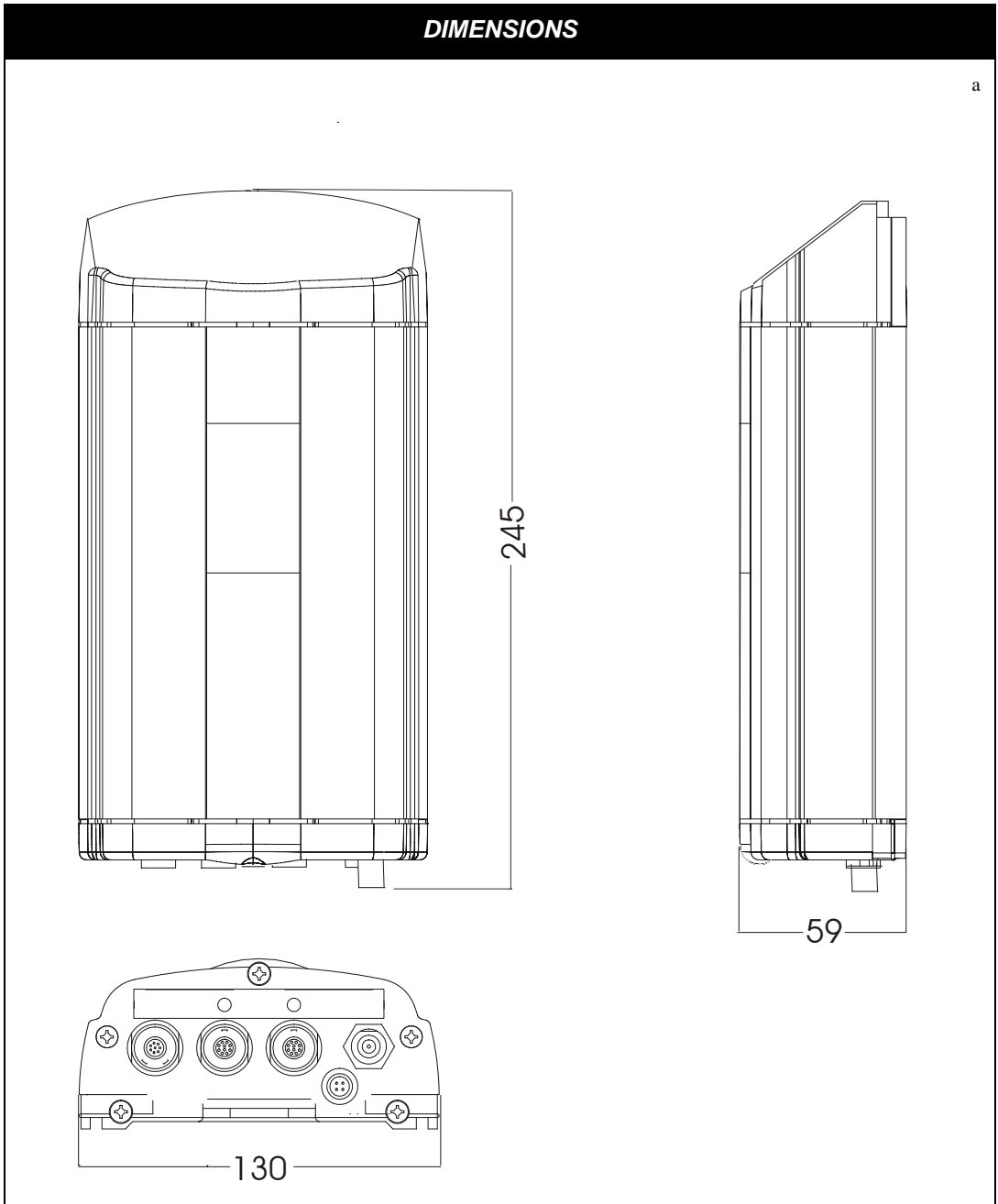

a. All dimension are in millimeters, please use the *Unit Conversion* section of the *GPS+ Reference Manual* for conversion to imperial measurements.

D.6.1 Port Pin-Outs

Table 44: ProPak-4E Serial Port Pin-Out Descriptions

Connector Pin No.	COM1		COM2	
	RS232	RS422	RS232	RS422
1	N/C	RXD1(-)	DCD2	RXD2(-)
2	RXD1	RXD1(+)	RXD2	RXD2(+)
3	TXD1	TXD1(+)	TXD2	TXD2(+)
4	N/C	RTS1(-)	DTR2	RTS2(-)
5	GND	GND	GND	GND
6	N/C	CTS1(-)	N/C	CTS2(-)
7	RTS1	RTS1(+)	RTS2	RTS2(+)
8	CTS1	CTS1(+)	CTS2	CTS2(+)
9	N/C	TXD1(-)	N/C	TXD2(-)

Table 45: ProPak-4E I/O Port Pin-Out Descriptions

Connector Pin No.	Signal Name	Signal Description
1	VARF	Variable frequency out
2	PPS	Pulse per second
3	MSR	Measure output
4	Event1	Mark 1 input
5	PV	Valid position available
6	GND	Digital ground
7	GND	Digital ground
8	GND	Digital ground

☒ For strobe signal descriptions, please see *Section 3.3.1, Strokes on Page 36*.

D.6.2 Cables

D.6.2.1 12V Power Adapter Cable (NovAtel part number 01016331)

The power cable supplied, see *Figure 69*, allows you to connect a DC power source of your choice. It is conveniently equipped with a 12V power adapter for supplying +12 VDC while operating in the field. The output from the power adapter utilizes a 4-pin LEMO connector (LEMO part number: FGJ.0B.304.CNLD52Z). For field replacement of the LEMO connector, please see *Appendix C, Page 154* for a list of the manufacturers' part numbers.

The input power cable is fuse protected and has been changed from 4 amp to 2.5 amp. The 12V power adapter is equipped with a 3 Amp slow-blow fuse, located inside the adapter tip. The tip can be unscrewed to allow replacement of the fuse, if necessary. To ensure optimum performance when replacing the fuse first spring load the fuse. The adapter has an LED on its side panel to indicate that power is connected.

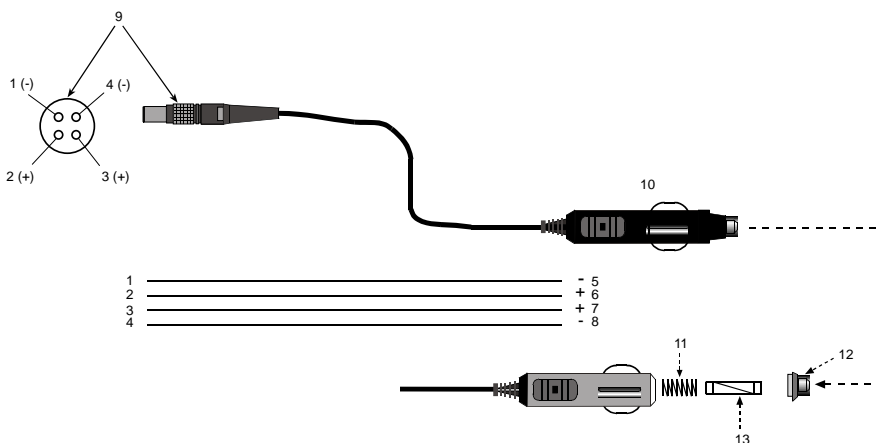

Reference	Description	Reference	Description
1	Black	5	Ground
2	Orange	6	+10 to +36 VDC
3	Red	7	+10 to +36 VDC
4	Brown	8	Ground
9	Red marker at top	12	Universal tip
10	12V adapter	13	3 amp slow-blow fuse
11	Spring		

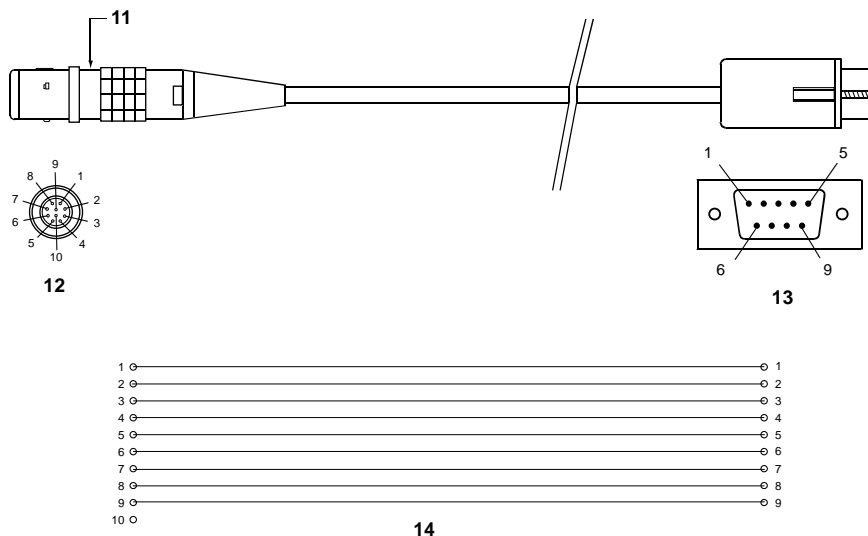

Figure 69: ProPak-4E Power Cable

D.6.2.2 Straight Through Serial Port Cable (NovAtel part number 01016383)

The straight through serial cable, see *Figure 70*, is used to connect the ProPak-4E to a modem or radio transmitter to propagate differential corrections. The end connectors are a 10-pin LEMO plug (LEMO part number: FGG.1K.310.CLAC55Z) to a 9-pin D-connector (DE9P plug). This cable looks identical to the null modem serial cable, see *Page 189*, but its use and part number differs. For field replacement of the LEMO connector, please see *Appendix C, Page 154* for a list of the manufacturers' part numbers.

The 10-pin plug on each cable can be plugged into either the COM1 or COM2 port on the ProPak-4E.



Reference	Description	Reference	Description
1	Brown	8	Violet
2	Black	9	Gray
3	Red	10	White
4	Orange	11	Red marker at top
5	Yellow	12	LEMO 10-pin plug
6	Green	13	DE9P (male)
7	Blue	14	10-conductor cable



Figure 70: ProPak-4E Straight Through Serial Cable

D.6.2.3 Null Modem Serial Port Cable (NovAtel part number 01016329)

The null modem serial cable, see *Figure 71*, is used to connect the ProPak-4E to a serial (RS232) communication port on a terminal/computer. The end connectors are a 10-pin LEMO plug (LEMO part number: FGG.1K.310.CLAC55Z) to 9-pin D-connector (DE9S socket). This cable looks identical to the straight serial cable, see *Page 188*, but its use and part number differs. For field replacement of the LEMO connector, please see *Appendix C, Page 154* for a list of the manufacturers' part numbers.

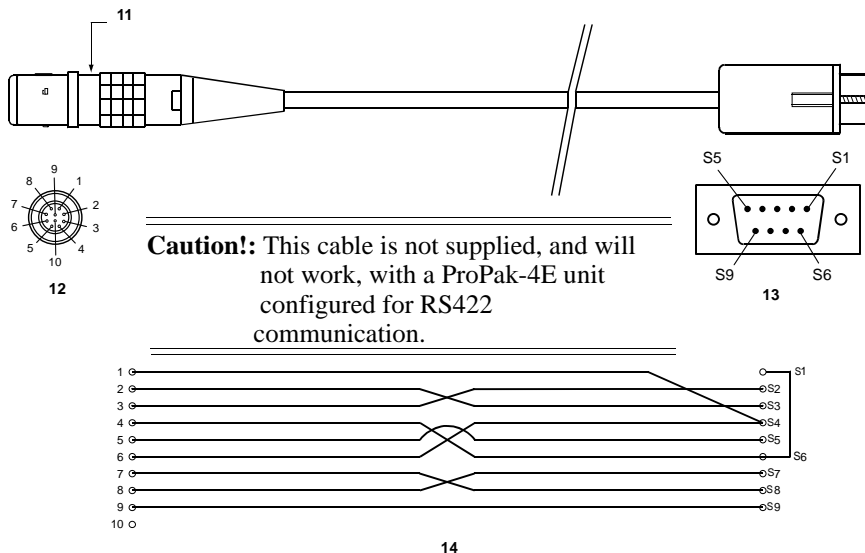

Reference	Description	Reference	Description
1	Brown	S1	White (not used, jumpered to S6)
2	Black	S2	Red
3	Red	S3	Black
4	Orange	S4	Green from 6 and Brown from 1
5	Yellow	S5	Yellow
6	Green	S6	Orange
7	Blue	S7	Violet
8	Violet	S8	Blue
9	Gray	S9	Gray
10	White	13	DE9S (female)
11	Red marker at top	14	10-conductor cable
12	LEMO 10-pin plug		

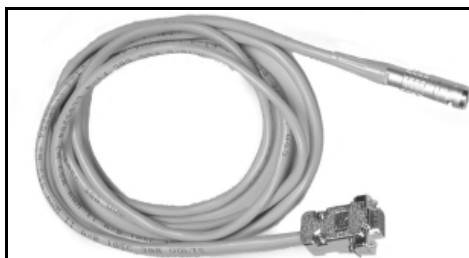
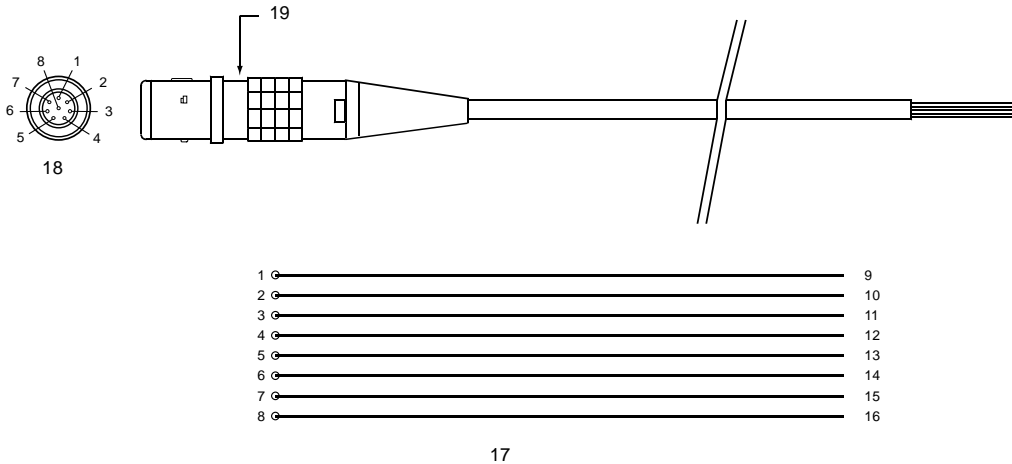

Figure 71: ProPak-4E Null Modem Cable

D.6.2.4 I/O Strobe Port Cable (NovAtel part number 01016330)

The ProPak-4E I/O strobe lines, see *Figure 72*, are available on the ProPak-4E rear panel from the 8 pin LEMO connector (LEMO part number: FGL.1K.308.CLLC45Z). For field replacement of the LEMO connector, please see *Appendix C, Page 154* for a list of the manufacturers' part numbers. See also *Input/Output Strobes on Page 171* for a list of the pinouts and descriptions for each of the I/O strobes along with electrical specifications.



Reference	Description	Reference	Description
1	Brown	11	MSR
2	Black	12	Event1
3	Red	13	STATUS
4	Orange	14	GND
5	Yellow	15	GND
6	Green	16	GND
7	Blue	17	8-conductor wire
8	White	18	LEMO 8-pin socket
9	VARF	19	Red marker at top of connector
10	1PPS		



Figure 72: ProPak-4E Strobe Cable

Index

A

- accumulated Doppler, 59
- accuracy
 - base station, 73
 - decrease in, 88
 - navigation, 57
 - positioning, 65–66, 72–73, 79, 116
 - RT-2 and RT-20, 81–83, 85, 116
- acquisition, 17
- aerial photograph, 79
- ambiguity
 - carrier phase, 17
 - fixed, 79
 - floating, 83
 - resolution, 81, 87
- antenna
 - active, 26, 28, 40
 - cables, 28–29, 155
 - card status, 105, 107
 - considerations, 34
 - dual-frequency, 28
 - input, 127, 135
 - models, 28, 155
 - power, 26, 40, 126
 - single-frequency, 28, 34
 - site, 67
- anti-static, 32, 151–153
- ascii, 48, 58, 92
- atmosphere, 17, 73, 82
- AUTH command, 100
- authorization, 100
- auxiliary status, 108

B

- base station
 - accuracy, 81
 - differential, 47, 71
 - health, 88
 - height, 87
 - overview, 73
 - parameters, 56

- position, 54, 65, 80
- baseline, 17, 43
- baud rate, 42
- bidirectional communication, 42
- binary, 48, 52, 109
- broadcast
 - corrections, 57, 70, 80
 - ephemeris, 67
 - error word, 109
 - observation data, 59
- buffer, 42, 82, 88

C

- cables, 142
 - antenna, 155
 - coaxial, 26, 28, 40
 - extended cable lengths, 29
 - null modem, 42
 - serial, 42
 - warranty, 11
- carrier phase
 - ambiguities, 17
 - differential positioning, 70
 - multipath errors, 82
 - overview, 17
 - RT-20 mode, 59
- cautions, 32, 40, 42
- CDGPS, 47, 74, 79
- channels, 105, 107
- chatter, 50
- choke ring, 87
- circuit board, 18, 153
- clock
 - bias, 80
 - external, 57
 - synchronization, 70
- CMR, 61
- coaxial, 26, 28, 40
- cold start, 116
- commands
 - antenna power, 40
 - default port settings, 42

- in GPSolution, 91, 99
- input, 43
- L-Band, 79
- OEM4 communication, 42
- position averaging, 65
- positioning, 119, 124
- pre-configuring, 45
- Volume 2, 155
- communication
 - bidirectional, 42
 - cable, 132, 139, 142, 148–150
 - port, 33
- configuration
 - additional equipment, 28
 - antenna, 29
 - differential, 72
 - overview, 17
 - port, 42, 44
 - RXCONFIG log, 58
 - status, 105–106
 - typical hardware, 41
- connector, 33–34
 - antenna, 118, 122, 127, 135, 143
 - COM, 127, 143
 - input/output, 118, 127, 135
 - power, 118, 122, 131, 138
- constellation, 87
- control signals, 17
- Convert software, 89, 92
- copyright, 2
- cross connecting, 14
- customer service, 82, 99

D**DC**

- antenna, 127, 135, 143
- path, 26
- power, 118, 135, 143

- dealer, 12, 99

default

- bit rates, 118, 123
- port settings, 42

differential

- corrections, 56, 65, 72–73, 88
- positioning, 17, 71

- digital, 26, 137

- dilution of precision (DOP), 64, 70

- directional communication, 42

- distance, 80

- Doppler, 59

- dynamics, 17

E

- earth-centered-earth-fixed (ECEF), 56

- ECEF, *see* earth-centered-earth-fixed

- electrostatic discharge (ESD), 32, 151–153

- elevation, 80, 82, 85

- ellipsoid, 56

- e-mail, 12

- ephemeris, 53

- change in, 56

- delay settings, 53

- errors, 67, 71, 82, 87

errors

- card status, 106–108

- due to atmosphere, 17

- ephemeris, 67, 82, 87

- ionospheric, 81–82, 87

- message, 43

- multipath, 82

- trigger, 105

- tropospheric, 82, 87

- ESD, *see* electrostatic discharge

- event messages, 106–107

- extended cable lengths, 29

- external oscillator, 39, 57, 118, 122

F

- features, 16, 43, 99–100

- firmware updates or upgrades, 12, 99–101

- fixed ambiguities, 79

- formats, 63

frequency

- L1/L2, 80

- measurements, 81

- RTCA-format messages, 52

G

- GEO, SBAS, 68

GPS

- overview, 66, 70–71, 73, 79–80

time, 50, 67
 GPSAntenna, 11, 155
 GPSolution software, 89, 155
 graphical user interface, 89
 ground plane, 87

H

handshaking, 42, 45
 hardware interface, 22
 header, 108
 health, 88
 height

- base station, 87
- difference, 87
- phase center, 73
- rover station, 87

 hexadecimal, 106, 110

I

I/O, 118, 123, 127, 135, 137
 idle time, 42
 impedance, 118, 122, 127, 135, 143
 input

- antenna, 127, 135
- commands, 43
- event, 124, 137

 installation, 16, 89
 integration, 16
 ionospheric, 67, 71, 81–82, 87

K

kinematic, 79, 86

L

latency

- base station, 88
- differential positioning, 71
- extrapolation error, 71
- reduction, 56
- RT-20 performance, 85

 latitude, 73
 L-Band, 74

- antenna, 28
- commands and logs, 78
- enable, 47–48
- receiver enclosure, 23

service levels, 76–77
 LED, 38, 105, 107, 109
 lightning protection, 14
 LNA, *see* low noise amplifier
 logs, 44

- CMR, 46
- in GPSolution, 91
- L-Band, 79
- position averaging, 65
- positioning, 80, 88
- RTCA, 46, 52
- RTCM, 46, 52, 55
- RTK, 83, 85
- status, 105, 108
- Volume 2, 155

 longitude, 73
 loss of lock, 80
 low noise amplifier (LNA), 26, 118, 122
 LVTTTL, 123

M

mark input (MKI), 124
 messages

- error, 43
- event, 106

 MKI, *see* mark input
 modem, 48
 mounting, 32
 multipath

- antenna models, 28
- interference, 70
- reduction, 87
- RT-2 performance, 82

N

Narrow Correlator tracking technology, 70
 navigation

- accuracy, 57
- applications, 18
- satellite system, 52
- standards, 54

 NMEA, 63
 noise

- ionospheric effects, 87
- reduction, 70
- satellite pair, 80

 Notices, 13–14

NovAtel Inc., 2, 11–12
null modem, 42

O

OCXO, *see* oscillators
offset, 70, 73, 80
OmniSTAR, 74
 HP, 77
 VBS, 76
operation, 16, 41
oscillators, 39, 57, 67, 118, 122
output
 connector, 127, 135
 data, 17

P

P code, 17
parity, 36, 42, 55, 62
pass-through logs, 48, 50
patent, 17
PDOP, *see* dilution of precision
polarity, 29
ports
 COM, 43–44, 56
 communication, 46, 52
 cross connecting, 14
 RXSTATUS EVENT log, 106
 serial, 42, 45
position
 base station, 43
 overview, 18
 RTK, 17
 static, 79
power
 connector, 118, 122, 131, 138
 requirements, 118, 122
 supply, 28
precision, 17, 70
priority mask, 105, 108
processing circuitry, 26
propagation, 67
pseudorange
 algorithms, 70
 corrections, 55, 57
 errors, 82
 measurement, 67, 73, 80
 positioning, 66, 70

solutions, 88

R

radio frequency (RF), 105, 107
 antenna power supply, 40
 GPSAntenna, 26
 GPSCard section, 26
 overview, 18
real-time
 kinematic software, 81
 positioning, 79
receiver status, 105–106, 108
redirect data, 48
reference station, *see* base station
remote station, *see* rover station
replacement parts, 154–155
reset, 107, 109, 124
resolution, 17
revision
 firmware, 99
 manual, 2, 196
RF, *see* radio frequency
Rinex, 92–93
root mean square (RMS), 85
rover station, 70
 accuracy, 81
 differential positioning, 46, 71, 80
 faster data update to, 56
 format messages, 54
 height, 87
RTCA, 52, 54
RTCM, 52, 56–57
RTCMV3, 60
RTK
 filter, 87–88
 logs, 83
 messages vs. accuracy, 81
 performance, 81, 87
 positioning, 17, 79
 radio, 42

S

satellite
 antenna location, 34
 DGNSS, 52
 ID, 55, 57
 overview, 17

- records, number of, 42, 53
- tracking, 85
- transmit, 26
- SBAS, 67, 69–70
- self-test, 43
- serial
 - cable, 42, 142
 - number, 99
 - port, 46
- signals, 17
- speed, 70
- static, 151–153
- station ID, 55
- status mask fields, 105
- strobe signals, 33, 119, 124
- support, 12
- surveying, 18, 73

T

- tag external events, 50
- TCXO, *see* oscillators
- technical specifications, 116–150
- tests (built-in), 105–106, 108–109
- time
 - GPS, 50
 - strokes, 33
 - tag, 49
- tracking
 - loops, 80
 - loss, 87
 - satellites, 85
- trigger, 105
- tropospheric, 67, 71, 82, 87
- troubleshooting, 111

U

- update or upgrade firmware, 12, 99–101
- USB connector, 142

V

- version, 100
- voltage, 118–119, 122, 124
- Volume 2, 16, 42, 44, 106–107, 155

W

- warnings, 13–14, 27–29

- warranty, 11, 27, 32, 40
- waypoint, 57
- website, 12
- WGS-84, 56
- windows in GPSSolution, 90–91
- WinLoad, 101

Y

- Y code, 17



Recyclable

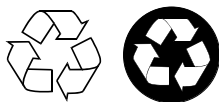

Printed in Canada on recycled paper