

SPECIFICATIONS

Diameter: 368.70 mm
Height: 64.64 mm
Weight: 5.2 kg
Mounting: 5/8" - 11 UNC, tripod bolt mount

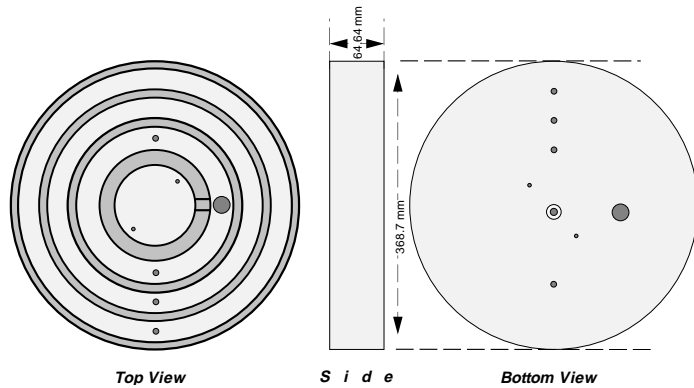

90 DAY LIMITED WARRANTY

NovAtel warrants this Product sold by NovAtel to be free from defects in materials and workmanship for a period of 90 days from the original purchase date.

NovAtel's responsibility with regard to this limited warranty shall be limited solely to repair or replacement, at its option, of any Product which fails during normal consumer use. This warranty does not extend to damage or failure which results from misuse, neglect, accident, alteration, abuse, improper installation or maintenance.

To exercise this limited warranty, you must obtain a RETURN MATERIAL AUTHORIZATION (RMA) NUMBER by calling 1-800-280-2242, or 403-295-4900, before shipping any product to NovAtel. Any defective product should be returned, insured and freight prepaid, securely packaged, to the following address:

NOVATEL COMMUNICATIONS LIMITED
GPS REPAIR CENTRE
6732 - 8th Street N.E.
Calgary, Alberta, Canada
T2E 8M4



© 1995 NovAtel Communications Ltd. All rights reserved.
Unpublished rights reserved under International copyright laws.
Printed in Canada.
March 1995
GI-00110033 Rev 1.0



Printed in Canada
on recycled paper

NovAtel GPSAntenna

ACCESSORY

CHOKERING

— Installation Guide —

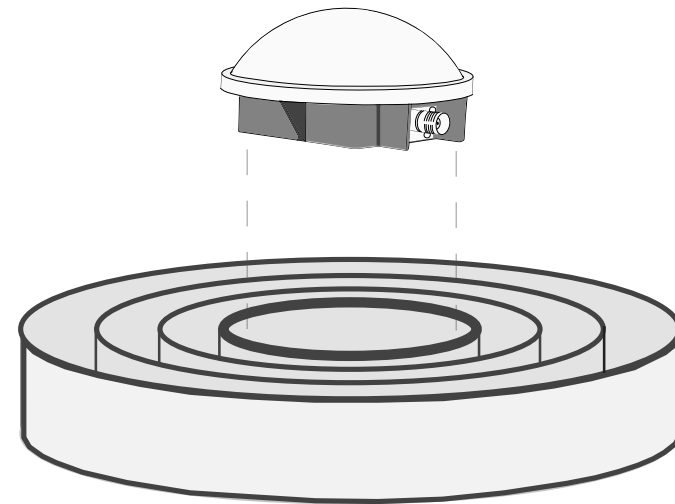

INTRODUCTION

The NovAtel GPSAntenna Choke Ring accessory has been designed to provide a light-weight, low-cost solution for the problem of GPS signal multipath reflections. It is intended for use with the NovAtel GPSAntenna Model 501. The Choke Ring's unique construction substantially reduces multipath measurement errors which in turn enables greater accuracy in your positioning calculations.

MATERIALS

Supplied:

- 1 - Choke Ring, Model A031
- 2 - Antenna mounting screws (6 - 32 x 1/2")

Other Required:

- 1 - GPSAntenna, Model 501
- 1 - Antenna cable (NovAtel GPS standard)
- 1 - Standard surveying tripod (with 5/8" mounting bolt), or other equivalent mounting structure

INSTALLATION

Before you begin setting up your NovAtel GPSAntenna Choke Ring, refer to Figure 1 on page 3. The procedure is as follows:

- 1) From the bottom of the Choke Ring, feed the TNC connector end of the antenna cable through the cable feed hole.
- 2) Connect the TNC connector to the GPSAntenna and tighten.
- 3) Seat the GPSAntenna into the center mounting area of the Choke Ring.
- 4) Insert each of the two antenna mounting screws through the bottom of the Choke Ring and tighten to the bottom of the GPSAntenna base.
- 5) Set the Choke Ring onto the tripod mounting plate and tighten the 5/8" bolt to the bottom of the Choke Ring base.

Figure 1 - Choke Ring Assembly

